

尊敬的客户，

您好！

我谨代表全球团队，在此感谢您选择豪孚迪集团，让我们成为您技术的延伸，体现您对患者整体健康的关注。不知您是否留意到，我们在品牌中添加了“集团 (Group)” 一词。这是为了更好地涵盖我们荣幸为您提供的更多价值。2019年，豪孚迪与Crosstex、Accutron和Palmero等各大品牌联手合作。如今，我们组成豪孚迪集团 (HuFriedyGroup)，并使用这一崭新的形象来代表我们多个品牌合计超过200年的口腔领域专业经验，以及我们对您和所有口腔专业人士的服务承诺。

在2021年的6月，豪孚迪集团刚刚成为了STERIS集团的新成员。STERIS集团是一家专注于感染预防领域以及手术产品和服务供应商。我们非常荣幸加入STERIS大家庭，成为其四大业务板块之一。尽管这些年来我们不断改变自己，但始终有一点从未改变：我们专注于为您提供口腔医学领域最高品质的产品、服务和教育体验。

正如您在本目录中将看到的，我们现在向您提供的产品种类比以往任何时候都更加丰富。以口腔器械组合和感染预防产品和服务作为核心，我们将产品线拓展到诊所、学校、政府机构以及医疗服务组织每天使用的各类用品。从个人防护设备到手术室用品和牙椅水路管理解决方案，我们目前拥有超过40,000种产品，不仅关注于器械方面，还涵盖了口腔更多领域，帮助您更好地打造完美的技艺，助您不断探索和发现口腔医学的更多可能性。

我们的承诺是帮助您成为最佳实践者。在您推动口腔医学不断前进发展的旅程中，我们将一直相伴。无论您身处世界何地，我们将始终如一地实践我们的承诺，为您提供您所需要的一切，我为此感到无比的激动和期待。



您诚挚的朋友，

A handwritten signature in blue ink that reads "Andy Xilas". The signature is fluid and cursive.

Andy Xilas
总裁

各位牙医朋友，

衷心感谢您对豪孚迪品牌的支持和信任！

豪孚迪品牌自创立以来，一直致力于为全球牙科从业人员提供最高质量的产品和服务。历经多年发展，在产品不断的创新和研发过程中，其应用领域从牙周，拓展到种植，正畸，修复和牙体等全科覆盖。随后引入感控相关产品和设备，从单一的器械供应商，走向更多元化的服务和支持。

豪孚迪品牌在中国市场深耕多年，致力于为中国本地牙医提供全球最高质量的口腔器械产品和优质服务。我们的目标是为您提供最好的技术支持和临床操作体验，通过器械的设计，工艺和临床使用，提高临床效率和准确性，以助力您更好的服务患者。此次出版豪孚迪中文产品目录，优选了豪孚迪品牌下最受中国牙医认可的器械和服务项目整理成册，这不仅是我们产品的展示，更是我们服务理念体现。

我们相信，豪孚迪的产品和服务将继续为您和您的患者带来更好的体验。我们深知您对高品质器械的需求和偏好，将继续努力研发新产品，提供全方位的技术支持，以满足中国牙科诊疗水平日益发展提高的要求和本地患者需求。我们更将继续关注客户满意度，与您建立长期稳定的合作关系，力争为您提供最专业的服务。

希望我们的努力可助力您实现完善的临床治疗、达到卓越的诊疗效果，同时保障患者和员工的安全，使您成为临床实践的佼佼者。



最后，再次感谢您对豪孚迪品牌的支持和信任！

A handwritten signature in blue ink that reads "Doris Jia". The signature is cursive and stylized.

Doris Jia
副总裁/中国区销售、市场及客户服务

公司发展历程	2
---------------	----------



口腔全科器械及相关产品	A1
--------------------	-----------

手动洁刮治类器械	A101
----------	------

器械维护与保养	A201
---------	------

诊断类器械	A301
-------	------

种植体维护器械	A401
---------	------

牙髓治疗器械	A501
--------	------

修复类器械	A601
-------	------

正畸类器械	A701
-------	------

外科类器械	A801
-------	------



器械再处理与灭菌	B1
-----------------	-----------

器械管理	B101
------	------

器械再处理	B201
-------	------



牙科用水管理	C1
---------------	-----------

索引	D1
-----------	-----------



公司发展历程

豪孚迪集团在口腔器械制造、感染预防和器械再处理领域享有盛名，拥有累积200多年的行业经验。豪孚迪集团由Accutron、Crosstex、Hu-Friedy和Palmero 品牌整合而成，为口腔专业人士提供临床实践所需的产品、服务和解决方案。豪孚迪集团多年来致力于产品的研发、服务和教育研究，助力医生达成临床预期、为患者带来临床保障和安全。

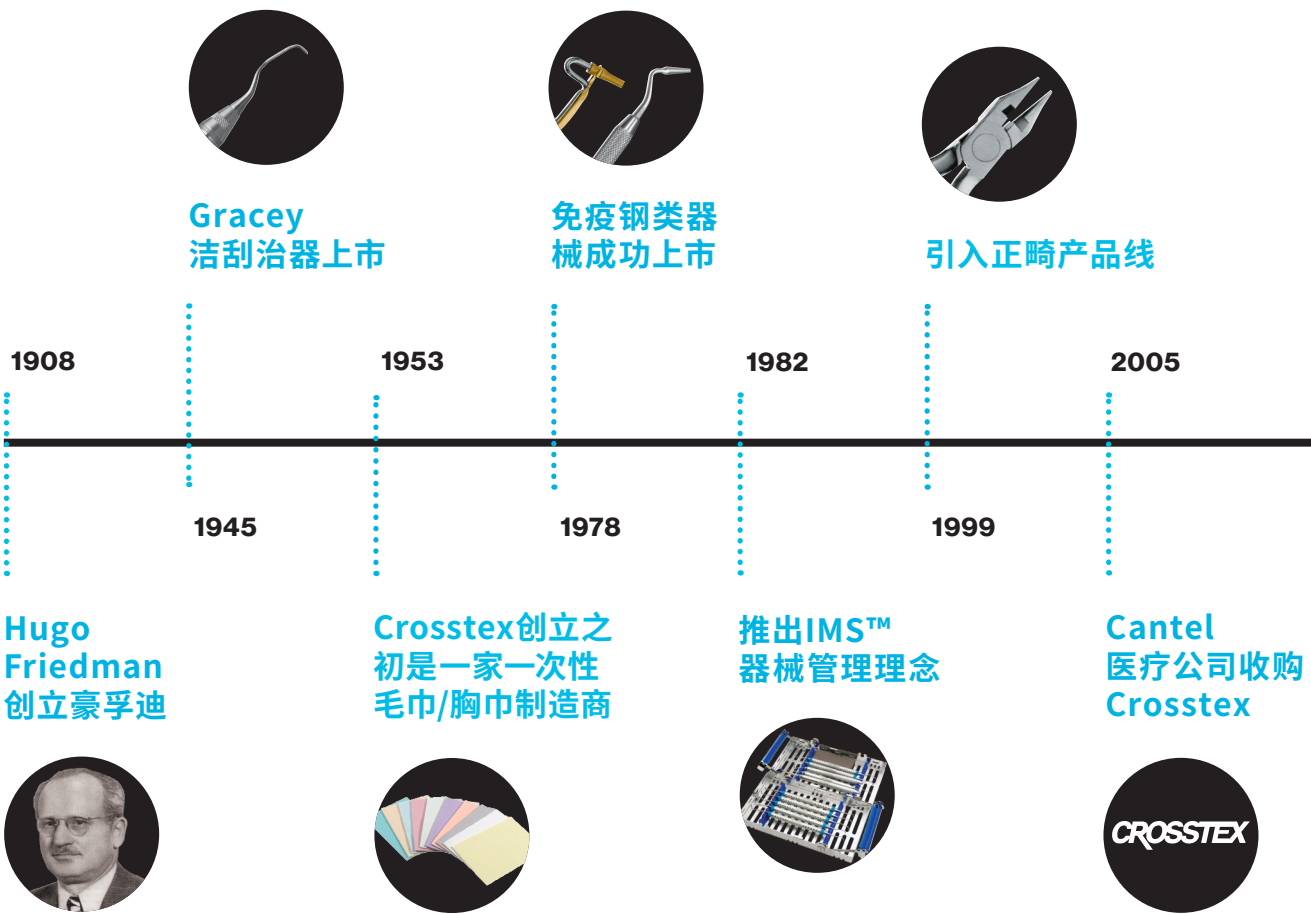



公司总部位于美国芝加哥，产品销往全球100多个国家。口腔事业部在德国、意大利、中国和日本均设有办事处。

豪孚迪集团的历史可以追溯到1908年。一个多世纪以来，我们致力于产品的创新和服务，力求为口腔专业人士带来更好的实践体验。诚邀您与我们一起回顾豪孚迪的传奇历史并见证40000多种产品的里程碑。

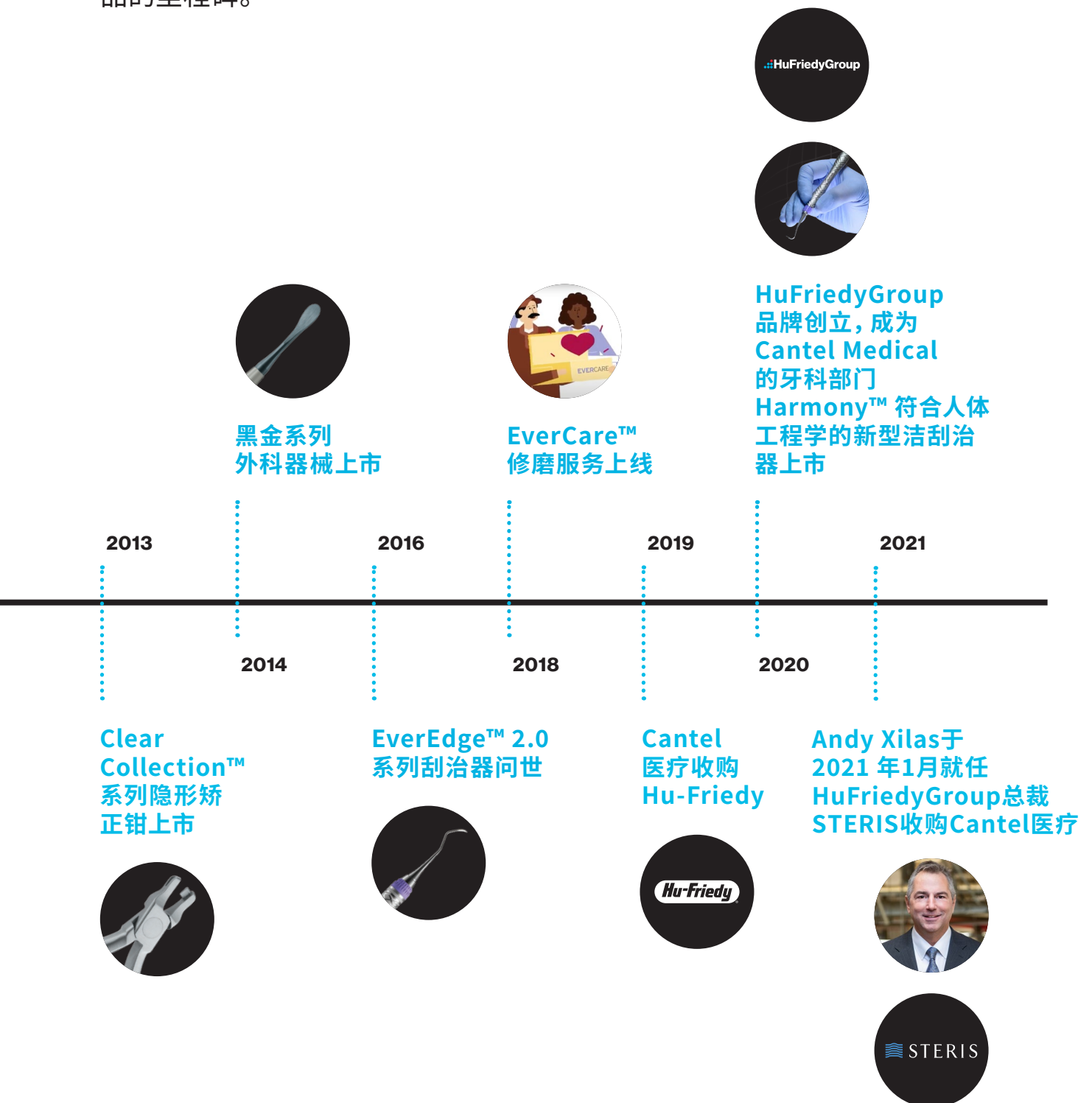

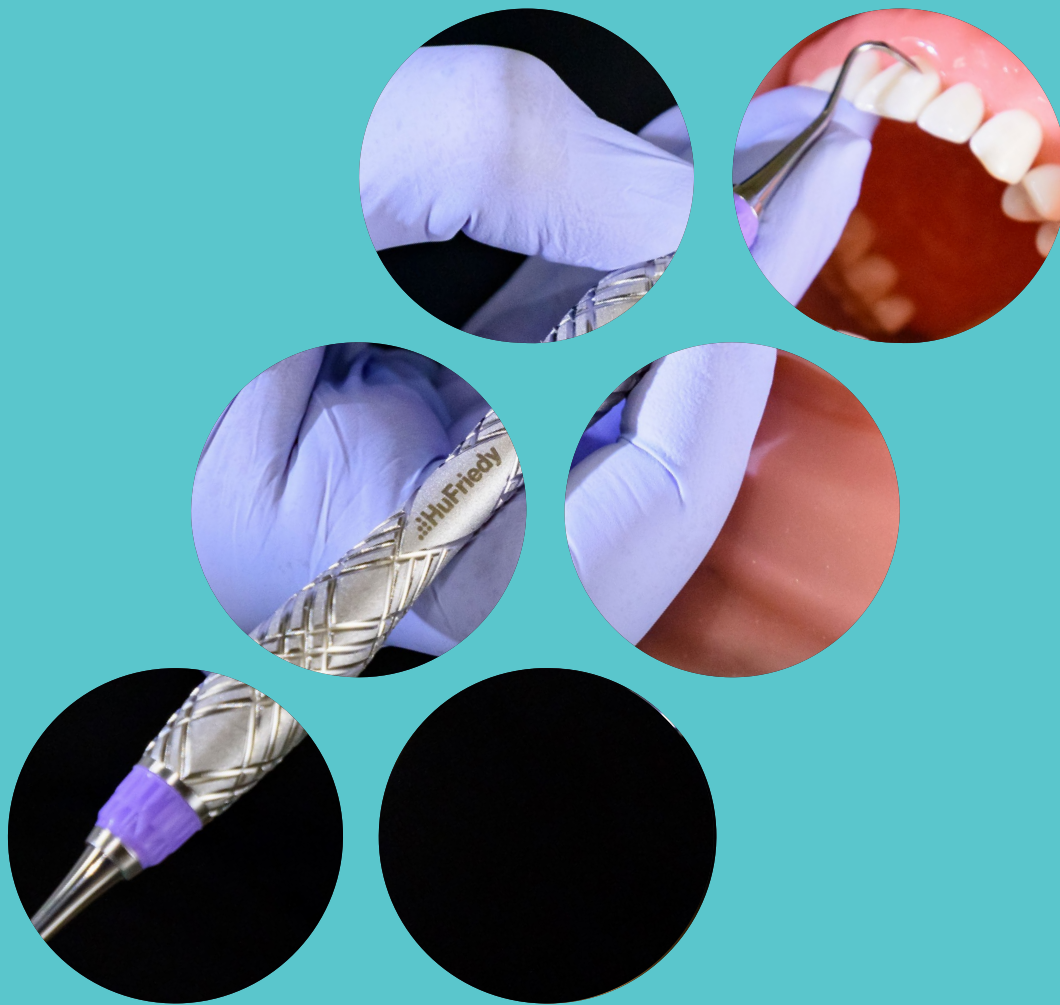

本图册以及本图册收录的内容,包括但不限于所有文字、数据、图片、图表、版面设计、排版方式、标识的所有权、著作权等知识产权以及其他权利均为 Hu-Friedy Mfg. Co., LLC及其附属公司或关联公司专属所有。未经事先书面许可,不得擅自使用,包括但不限于以任何形式使用、复制、转让、发行、传播、转载、出版、修改、改编或曲解本图册收录的内容。

除非另有说明,否则所有标识均在 Hu-Friedy Mfg. Co., LLC及其附属公司或关联公司的商标权的范围内,包括公司名称、产品名称、文字/图形及其组合、品牌名称、标识等。未经事先书面许可,不得使用本图册中任何商标的全部或部分。

豪孚迪医疗器械(上海)有限公司

地址:上海市浦东新区康桥东路1365弄29号 客服电话:021-68183182*843

邮箱:customer_service_china@hu-friedy.com

中文网站: <https://www.hufriedygroup.com/china/zh-hans>



口腔全科器械及相关产品

从手工刮治器械到正畸器械，外科器械，最终完成口腔全科器械的覆盖。自1908年创立，豪孚迪逐渐成长为口腔器械的专业品牌。通过不断的创新和研发，助力口腔医生实现理想的临床诊疗结果。

手动洁刮治类器械	A101
器械维护与保养	A201
诊断类器械	A301
种植体维护器械	A401
牙髓治疗器械	A501
修复类器械	A601
正畸类器械	A701
外科类器械	A801

手柄	A102
Gracey 刮治器	A103
标准Gracey 刮治器	A103
Gracey After Five™ 刮治器	A104
Gracey Mini Five™ 刮治器	A104
Gracey Micro Mini Five™ 刮治器	A105
Pattison Gracey Lite 刮治器	A106
Vision 刮治器	A106
通用型刮治器	A107
Langer 刮治器	A107
Columbia 通用型刮治器/通用型刮治器	A107
Furcation 刮治器	A108
镰形洁治器	A109
Nevi™ 洁治器	A109
前牙镰形洁治器	A110
后牙镰形洁治器	A110
洁刮治器	A111
McCall 洁刮治器	A111
Cattoni 洁刮治器	A112
刮治锉和牙周凿	A113
牙周凿	A113
DiamondTec™ 刮治锉	A113

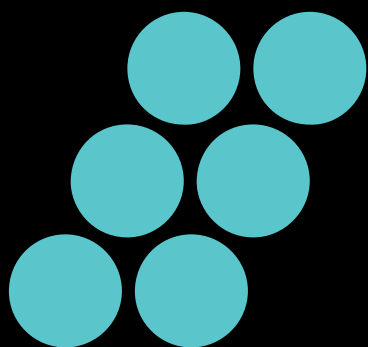

手动洁刮治类器械

手柄

EverEdge™ 2.0 手柄

Harmony™ 哈曼尼手柄

9 号柄

8号彩色树脂柄



免疫钢手柄

6号柄

7号柄

8号树脂柄

2号柄

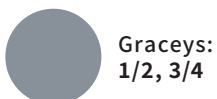

Graceys:
1/2, 3/4

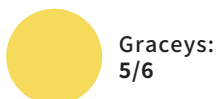

Graceys:
5/6

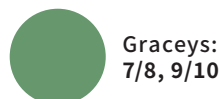

Graceys:
7/8, 9/10



Graceys:
11/12, 15/16



Graceys:
13/14, 17/18



前牙洁治器



后牙洁治器



通用洁刮治器



Gracey 刮治器

Gracey 刮治器均为单刃口设计，与杆部呈70度角，提供完美的工作角度。

标准Gracey 刮治器

标准的Gracey刮治器，用于深层刮治，根面清洁及牙周清创。Gracey 加硬型刮治器略厚，较标准刮治器弹性小，可用于去除中等或者重度结石。标准、加硬型Gracey 刮治器具有相同的刃口。



Gracey 5/6 刮治器	标准	加硬型
Harmony™哈曼尼手柄, EE2.0	SG5/6XE2	
9号柄, EE2.0	SG5/69E2	SG5/6R9E2
#C8 黄色树脂手柄, EE2.0	SG5/6C8E2	



Gracey 7/8 刮治器	标准	加硬型
Harmony™哈曼尼手柄, EE2.0	SG7/8XE2	
9号柄, EE2.0	SG7/89E2	SG7/8R9E2
#C8 绿色树脂手柄, EE2.0	SG7/8C8E2	



Gracey 11/12 刮治器	标准	加硬型
Harmony™哈曼尼手柄, EE2.0	SG11/12XE2	
9号柄, EE2.0	SG11/129E2	SG11/12R9E2
#C8 橘色树脂手柄, EE2.0	SG11/12C8E2	



Gracey 13/14 刮治器	标准	加硬型
Harmony™哈曼尼手柄, EE2.0	SG13/14XE2	
9号柄, EE2.0	SG13/149E2	SG13/14R9E2
#C8 蓝色树脂手柄, EE2.0	SG13/14C8E2	



Gracey After Five™ 刮治器

Gracey After Five™ 刮治器柄末端较标准刮治器长3mm，刃口厚度薄10%。较薄的刃口降低进入牙周袋时对组织的牵拉。



Gracey 5/6 After Five™ 刮治器

9号柄, EE2.0 [SRPG5/69E2](#)
#C8 黄色树脂手柄, EE2.0 [SRPG5/6C8E2](#)



Gracey 7/8 After Five™ 刮治器

9号柄, EE2.0 [SRPG7/89E2](#)
#C8 绿色树脂手柄, EE2.0 [SRPG7/8C8E2](#)



Gracey 11/12 After Five™ 刮治器

9号柄, EE2.0 [SRPG11/129E2](#)
#C8 橘色树脂手柄, EE2.0 [SRPG11/12C8E2](#)



Gracey 13/14 After Five™ 刮治器

9号柄, EE2.0 [SRPG13/149E2](#)
#C8 蓝色树脂手柄, EE2.0 [SRPG13/14C8E2](#)

Gracey Mini Five™ 刮治器

Gracey Mini Five™刮治器柄末端比标准刮治器长3mm，刃薄10%，短50%，是深刮的理想工具。



Gracey 5/6 Mini Five™ 刮治器	标准	加硬型
Harmony™哈曼尼手柄, EE2.0	SAS5/6XE2	
9号柄, EE2.0	SAS5/69E2	SAS5/6R9E2
#C8 黄色树脂手柄, EE2.0	SAS5/6C8E2	



Gracey 7/8 Mini Five™ 刮治器	标准	加硬型
Harmony™哈曼尼手柄, EE2.0	SAS7/8XE2	
9号柄, EE2.0	SAS7/89E2	SAS7/8R9E2
#C8 绿色树脂手柄, EE2.0	SAS7/8C8E2	



Gracey 11/12 Mini Five™ 刮治器	标准	加硬型
Harmony™ 哈曼尼手柄, EE2.0	SAS11/12XE2	
9号柄, EE2.0	SAS11/129E2	SAS11/12R9E2
#C8, 橘色树脂手柄, EE2.0	SAS11/12C8E2	



Gracey 13/14 Mini Five™ 刮治器	标准	加硬型
Harmony™ 哈曼尼手柄, EE2.0	SAS13/14XE2	
9号柄, EE2.0	SAS13/149E2	SAS13/14R9E2
#C8, 蓝色树脂手柄, EE2.0	SAS13/14C8E2	

Gracey Micro Mini Five™ 刮治器

Gracey Micro Mini Five™ 刮治器工作柄更长, 刃口较标准刮治器短50%且薄28%。



Gracey 1/2 Micro Mini Five™ 刮治器	
9号柄, EE2.0	SMS1/29E2



Gracey 7/8 Micro Mini Five™ 刮治器	
9号柄, EE2.0	SMS7/89E2



Gracey 11/12 Micro Mini Five™ 刮治器	
9号柄, EE2.0	SMS11/129E2



Gracey 13/14 Micro Mini Five™ 刮治器	
9号柄, EE2.0	SMS13/149E2



Pattison Gracey Lite 刮治器

简称AP刮治器，是在原有 Gracey 刮治器的基础上进行了一系列改良。它具有短小灵巧的工作端，刃部呈60°角，轻松进入较紧的牙周袋口同时保持较好的牙面贴合度。



Pattison Gracey Lite 1/2 刮治器
9号柄 **SG1/29APE2**



Pattison Gracey Lite 7/8 刮治器
9号柄 **SG7/89APE2**



Pattison Gracey Lite 11/12 刮治器
9号柄 **SG11/129APE2**



Pattison Gracey Lite 13/14 刮治器
9号柄 **SG13/149APE2**

Vision 刮治器

Vision 刮治器是一款改良的Gracey刮治器，柄部5mm和10mm的标记可评估进入牙周袋的深度。“+”的标志识别刃口的位置，另外短小且弯曲的刃口设计是根面及根分叉区的理想工具。



Sub-0 Vision 刮治器
6号柄 **SGCSUB-06**



1/2 Vision 刮治器
6号柄 **SGC1/26**



11/12 Vision 刮治器
6号柄 **SGC11/126**



13/14 Vision 刮治器
6号柄 **SGC13/146**



通用型刮治器

Langer 刮治器

Langer刮治器的设计结合了通用刮治器的优点，具有双切割刃口和特殊的柄部设计。Langer刮治器最初设计为3支一套（1/2, 3/4, 5/6），可适用于大多数的刮治和牙周手术。



Langer 1/2 刮治器

9号柄, EE2.0

SL1/29E2



Langer 3/4 刮治器

9号柄, EE2.0

SL3/49E2



Langer 5/6 刮治器

9号柄, EE2.0

SL5/69E2

Columbia 通用型刮治器/通用型刮治器

Columbia 刮治器有两个平行的切割刃，末端圆头设计。可应用于前牙，后牙，是一款通用型刮治器。



Columbia 2R/2L 通用刮治器

9号柄, EE2.0

SC2R/2L9E2

#C8 紫色树脂手柄, EE2.0

SC2R/2LC8E2



7/8 Younger-Good 刮治器

9号柄, EE2.0

SYG7/89E2

#C8 紫色树脂手柄, EE2.0

SYG7/8C8E2



Columbia 4R/4L 通用刮治器

9号柄, EE2.0

SC4R/4L9E2

#C8 紫色树脂手柄, EE2.0

SC4R/4LC8E2



Columbia 13/14 通用刮治器

9号柄, EE2.0

SC13/149E2

#C8 紫色树脂手柄, EE2.0

SC13R/14LC8E2



Furcation 刮治器

Furcation 刮治器用于根面凹陷和分叉区域。DeMarco刮治器适用于前牙舌侧区域的清洁。



#1 DeMarco Furcation 刮治器

6号柄 **SDM16**



#2 DeMarco Furcation 刮治器

6号柄 **SDM26**

Quetin Furcation 颊舌侧刮治器

0.09 mm

6号柄

SQBL16



Quetin Furcation 颊舌侧刮治器

1.3 mm

6号柄

SQBL26

Quetin Furcation 近远中刮治器

0.09 mm

6号柄

SQMD16



Quetin Furcation 近远中刮治器

1.3 mm

6号柄

SQMD26

Quetin 唇舌侧刮治器

6号柄

SQLL36



镰形洁治器

镰形洁治器具有双切割刃，背面是尖的，形成一个三角形横截面。工作刃有直和弯两种形态。镰形洁治器主要用于龈上洁治。

Nevi™ 洁治器

Nevi™ 洁治器具有独特的角度和设计，方便进入间隙区域。



Nevi™ 1 前牙洁治器

9号柄, EE2.0

SCNEVI19E2



Nevi™ 1/H5 前牙洁治器

9号柄, EE2.0

SNEV1/H59E2



Nevi™ 2 后牙洁治器

9号柄, EE2.0

SCNEVI29E2



Nevi™ 3 后牙洁治器

9号柄, EE2.0

SCNEVI39E2



Nevi™ 4 后牙洁治器

9号柄, EE2.0

SCNEVI49E2



前牙镰形洁治器

前牙洁治器具有直或轻微角度的杆部设计。工作刃分为带有曲度、直的和两者相结合的形式。



H6/7 洁治器

9号柄, EE2.0

SH6/79E2



H5/33 洁治器

9号柄, EE2.0

SH5/339E2

后牙镰形洁治器

后牙洁治器设计反角杆部可以进入难于达到的位置。如后牙近中面。工作刃分为弯曲的和直的。



204 后牙洁治器

6号柄

S2046



204S 后牙洁治器

9号柄, EE2.0

S204S9E2



204SD 后牙洁治器

9号柄, EE2.0

S204SD9E2



洁刮治器

McCall 洁刮治器

McCall 洁刮治器用于后牙的器械。具有双切割边缘，提供圆形或尖形末端。



McCall 13/14 刮治器

9号柄, EE2.0

SM13/149E2



McCall 13/14 尖头刮治器

9号柄, EE2.0

SM13/14S9E2



McCall 17/18 刮治器

9号柄, EE2.0

SM17/189E2

Cattoni 洁刮治器

设计用于去除中度至重度龈上和牙龈下结石。



Cattoni 103/106 刮治器

6号柄

S103/1066



Cattoni 104/105 刮治器

6号柄

S104/1056



Cattoni 107/108 刮治器

6号柄

S107/1086



刮治锉和牙周凿

牙周凿

牙周凿用于下前牙区，以推的方式去除邻面牙间隙处的牙石。

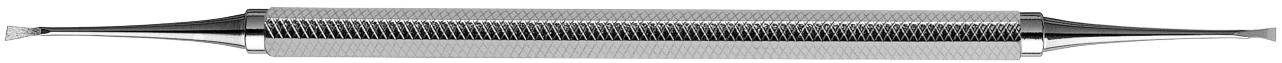

Darby-Perry 5K/6K 凿

2号柄

SDP5/6K



Darby-Perry 9K/11K 凿

2号柄

SDP9/11K

DiamondTec™ 刮治锉

刮治锉工作端360度覆盖金刚砂。理想的根分叉、根凹陷、近中/远端线角和发育凹槽的刮治。



DiamondTec™ 近远中向刮治锉

7号柄

SDCM/D7



DiamondTec™ 颊舌向刮治锉

7号柄

SDCN7

Sidekick™ 电动修磨机	A202
金刚砂修磨卡	A203
磨石	A204
阿肯色磨石	A204
印度磨石	A205
陶瓷磨石	A205

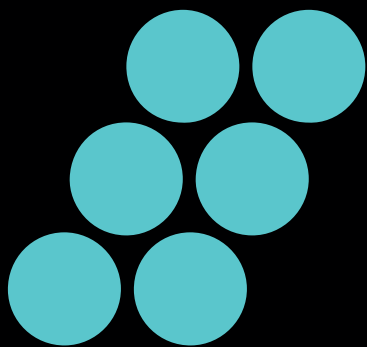

器械维护与保养

Sidekick™ 电动修磨机



Sidekick™ 电动修磨机套装

[SDKKIT](#)

Sidekick™ 替换磨石

陶瓷磨石粗颗粒

[SDKSTCOARS](#)

阿肯色磨石

[SDKSTONEA](#)

陶瓷磨石

[SDKSTONEC](#)

Sidekick™ 电动修磨机替换导板

[SDKGPLATE](#)

Sidekick™ 电动修磨机替换螺丝

[SDKGPSCREW](#)

Sidekick™ 电动修磨机替换磨石片

[SDKCLIP](#)

金刚砂修磨卡

金刚砂修磨卡是由均质的工业金刚砂颗粒附着在硬质，平滑的金属表面制成。可采用超声波清洗机和蒸汽清洁。



金刚砂修磨卡套装

DSCSET

金刚砂修磨卡

超细颗粒 **DSCXFINE**

细颗粒 **DSCFINE**

中等颗粒 **DSCMED**



磨石

阿肯色磨石

采用天然阿肯色州的石头材料，分为细颗粒和超细颗粒，非常适合日常器械修磨维护。阿肯色磨石在使用前需涂上一层薄薄的油，以确保最佳性能。



阿肯色磨石套装	SSKITA
4号阿肯色磨石，细颗粒	SS4
299号圆锥形阿肯色磨石，超细颗粒	SS299
检测条，6支装	PTS
磨石油	SSO
放大镜	LENS



4号阿肯色磨石，细颗粒

SS4

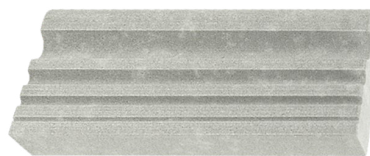

5号阿肯色磨石，细颗粒

SS5



2号圆柱形阿肯色磨石，超细颗粒

SS2



299号圆锥形阿肯色磨石，超细颗粒

SS299

印度磨石



1号 I 磨石, 细颗粒

SSF1

陶瓷磨石

硬质合成石, 有细颗粒、中等颗粒和粗颗粒。



双色陶瓷磨石

SSDGRIT



陶瓷圆柱磨石, 细颗粒

SSKC

牙周刻度探针	A302
Colorvue™ 树脂刻度探针	A302
Colorvue™ 生物型探针	A303
Colorvue™ Perioscreen 树脂刻度探针	A304
单头牙周刻度探针	A304
Nabers 牙周刻度探针	A305
Screening 牙周刻度探针	A305
探针	A306
双头探针	A306
XTS™ 铝钛氮涂层探针	A306
牙周刻度探针/探针	A307
口镜	A307
高清黑金系列口镜	A307
高清口镜	A308
镀铬口镜	A308
镊子	A309

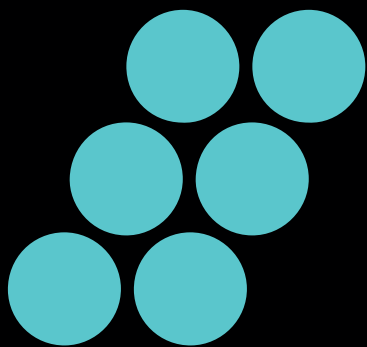

诊断类器械



牙周刻度探针

Colorvue™ 树脂刻度探针

采用黄色工作端结合黑色刻度标识，增强口内操作的视觉对比度，适用于天然牙和种植牙。具有一定的弹性并结合圆形的工作头，提高了患者的体验度，以及操作过程中对种植体的保护。



#UNC12 树脂刻度探针工作端
12个工作端
(1-2-3-4-5-6-7-8-9-10-11-12) **PCVUNC12PT**

#UNC12 树脂刻度探针套装
1个手柄+7个工作端
(1-2-3-4-5-6-7-8-9-10-11-12) **PCVNCKIT6**



#11 树脂刻度探针套装
1个手柄+7个工作端
(3-6-8-11) **PCV11KIT6**



#12 树脂刻度探针工作端
12个工作端
(3-6-9-12) **PCV12PT**



Williams 树脂刻度探针工作端
12个工作端
(1-2-3-5-7-9-10) **PCVWPT**



Oxford 树脂刻度探针工作端
12个工作端
(1-2-3-4-5-6-7-8-9-10-11-12-13-14-15) **PCVO12PT**



双头金属/树脂刻度探针
一端UNC15刻度探针/一端树脂探针 **PH06**



Oxford金属/树脂刻度探针套装
一端UNC15刻度探针/一端树脂探针 (6个可替换工作头) **PCVOKIT6**

Colorvue™ 生物型探针



生物型探针工作端
12个蓝色工作端 **PBTPB**



生物型探针工作端
12个绿色工作端 **PBTPG**



生物型探针工作端
12个白色工作端 **PBTPW**

生物型探针套装
3个手柄+绿、蓝、白每种各4个工作头 **PBTPKIT12**





Colorvue™ Perioscreen 树脂刻度探针



Goldstein 树脂探针套装
1个手柄+7个工作端 **PPSGKIT6**



Goldstein 树脂探针工作端
12个工作端 **PPSG12PT**

单头牙周刻度探针

用于探查牙周袋深度，附着水平，解剖结构以及牙龈出血情况。



UNC刻度探针
刻度标记1-15 **PCPUNC156**



Williams 刻度探针
刻度标记
1-2-3-5-7-8-9-10 **PQW6**



UNC 刻度探针
刻度标记 1-12 **PCPUNC126**



CP-11 刻度探针
刻度标记3-6-8-11 **PCP116**



CP-12 刻度探针
刻度标记 3-6-9-12 **PCP126**



Nabers 牙周刻度探针



#2 刻度探针

刻度标记 3-6-9-12

PQ2N6

Screening 牙周刻度探针



UNC15/11.5B 刻度探针

P15/11.5B6



WHO 刻度探针

刻度标记

3.5-5.5-8.5-11.5

PCP11.5B6



探针

采用Duraspond™钢, 特殊的可弯曲的材料, 具有高弹性以及弹性恢复能力, 保证临床精准的诊断检查。

双头探针



#1 探针

双头

EXD16



#5 探针

双头

EXD56



#TU-17/23 探针

双头

EXTU17/236

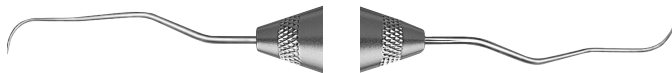

#11/12 结石探针

After Five 双头

EXD11/12A6

ODU 双头

EXD11/126

XTS™ 铝钛氮涂层探针



#5 XTS™ 探针

铝钛氮涂层, 双头

EXD5XTS



牙周刻度探针/探针



23/QOW Williams 探针/刻度探针

#6 号柄

XP23/QOW6



23/UNC15 探针/刻度探针

#6 号柄

XP23/UNC6

口镜

高清黑金系列口镜



#5 双面黑金系列高清口镜

MIR5DSHDB



#5 单面黑金系列高清口镜

MIR5HDB



高清口镜



#4 单面高清口镜

镜面直径 22 mm

MIR4HD

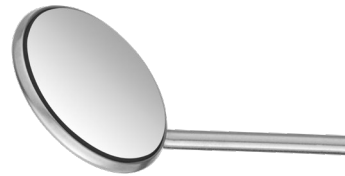

#5 单面高清口镜

镜面直径 24 mm

MIR5HD



#4 双面高清口镜

镜面直径 22 mm

MIR4DSHD



#5 双面高清口镜

镜面直径 24 mm

MIR5DSHD

镀铬口镜



#4 单面口镜

镜面直径 22 mm

MIR4

3支/包

MIR4/3

12支/包

MIR4/12



#5 单面口镜

镜面直径 24 mm

MIR5

3支/包

MIR5/3



#4 双面口镜

镜面直径 22 mm

MIR4DS

3支/包

MIR4DS/3



#5 双面口镜

镜面直径 24 mm

MIR5DS

3支/包

MIR5DS/3

6支/包

MIR5DS/6

镊子



Utility Pick-Up 镊子

DPU17



#18L 锁镊

DP18L



#317 镊子

喙部光滑

DP317



#18 镊子

DP18



#2 College 镊子

DP2

钛刮治器

A402

Implacare™ 种植体维护洁/刮治器

A403

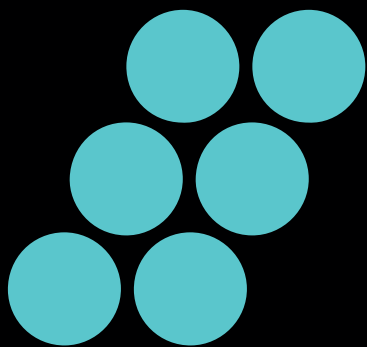

种植体维护器械

钛刮治器

采用与种植体和基台相同材质的钛合金制成，用于种植体维护，清创和生物膜去除。蓝绿色氧化钛涂层，增强口腔内的视觉对比度。优化的锋利度，精细打磨的刃口，以及后续的修磨服务，可以保持器械持久锐利，延长使用寿命。



钛种植体洁治器 204SD

IMP204SDT



钛种植体刮治器 Langer 1/2

IMPLG1/2T



钛种植体刮治器 Mini Five 1/2

IMPM1/2T



钛种植体刮治器 Mini Five 11/12

IMPM11/12T



钛种植体刮治器 Mini Five 11/12

IMPM13/14T



Implacare™ 种植体维护洁/刮治器

Implacare™ II 种植体维护洁/刮治器，由一种优质树脂制成，提供更薄的新型工作端，更好地适应种植体，方便操作。



Implacare™ II Langer 1/2 刮治工作头

12对 刮治工作头 **IMPLLG1/2**

Implacare™ II Langer 1/2 刮治器套装

手柄+ 12对 刮治工作头 **IMPLLG1/26**



Implacare™ II Barnhart 5/6 刮治工作头

12对 刮治工作头 **IMPLBH5/6**

Implacare™ II Barnhart 5/6 刮治器套装

手柄+ 12对 刮治工作头 **IMPLBH5/66**



Implacare™ II Columbia 4R/4L 刮治工作头

12对 刮治工作头 **IMPL4R/4L**

Implacare™ II Columbia 4R/4L 刮治器套装

手柄+ 12对 刮治工作头 **IMPL4R/4L6**



Implacare™ II H6/7 刮治工作头

12对 刮治工作头 **IMPLH6/7**

Implacare™ II H6/7 刮治器套装

手柄+ 12对 刮治工作头 **IMPLH6/76**



Implacare™ II 204S 洁治工作头

12对 洁治工作头 **IMPL204S**

Implacare™ II 204S 洁治器套装

手柄+ 12对 洁治工作头 **IMPL204S6**



Implacare™ II 种植体维护套装

手柄+ 5对 工作头 **IMPLINTRO6**

Implacare™ II 种植体维护套装

手柄+ 12对 工作头 **IMPLSORT6**

Implacare™ II 洁/刮治工作头套装

12对 工作头 **IMPLSORT**

种植体维护套装

包含2个手柄，5对
Implacare™工作头，
4套彩色探针头（8个）

IMPCKITII



Implacare™ 树脂刮治器 - 不锈钢手柄

IMPHDL6

橡皮障夹	A502
前牙橡皮障夹	A502
前磨牙橡皮障夹	A502
后牙通用橡皮障夹	A503
上颌磨牙橡皮障夹	A504
下颌磨牙橡皮障夹	A504
橡皮障辅助工具	A505
橡皮障布	A507
根尖手术器械	A508
金属口镜	A508
显微口镜	A509
根尖区刮匙—直杆	A509
根尖挖匙—弯曲杆	A510
充填器	A510
充填/研磨器	A511
倒充填器	A512
显微根尖探针	A512
探针	A513
根管挖匙	A514
侧方加压充填器	A515
镍钛侧方加压充填器	A516
垂直加压充填器	A517
根管镊	A519
根管桩/银针镊	A519
尺子	A520
锁镊	A521

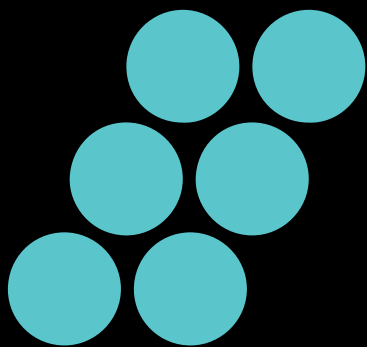

牙髓治疗器械

我们提供的全线牙髓治疗器械，从常规治疗到复杂的显微外科手术器械，与全球行业专家共同研发生产，使其具有卓越的临床适应性，耐用性以及完整性。



橡皮障夹

前牙橡皮障夹



#9 橡皮障夹

不锈钢

RDCM9

黑金系列

RDCM9X

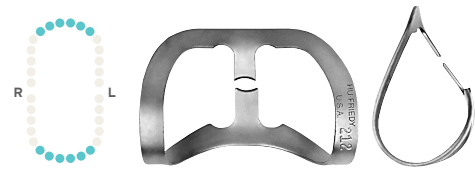

#212 橡皮障夹

不锈钢

RDCM212

黑金系列

RDCM212X

前磨牙橡皮障夹



#0 橡皮障夹

不锈钢

RDCM0

黑金系列

RDCM0X



#1 橡皮障夹

不锈钢

RDCM1

黑金系列

RDCM1X



#2 橡皮障夹

不锈钢

RDCM2

黑金系列

RDCM2X



#2A 橡皮障夹

不锈钢

RDCM2A

黑金系列

RDCM2AX



#2AS 橡皮障夹

不锈钢

RDCM2AS

黑金系列

RDCM2ASX



#27N 橡皮障夹

不锈钢

RDCM27N

黑金系列

RDCM27NX

后牙通用橡皮障夹



#10 橡皮障夹

不锈钢

RDCM10

黑金系列

RDCM10X



#11 橡皮障夹

不锈钢

RDCM11

黑金系列

RDCM11X

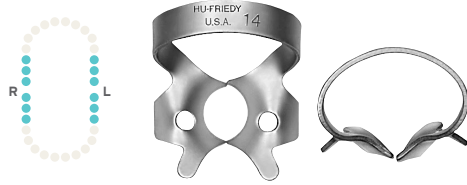

#14 橡皮障夹

不锈钢

RDCM14

黑金系列

RDCM14X



#14A 橡皮障夹

不锈钢

RDCM14A

黑金系列

RDCM14AX



#18 橡皮障夹 (无翼)

不锈钢

RDCM18

黑金系列

RDCM18X



#24 橡皮障夹 (无翼)

不锈钢

RDCM24

黑金系列

RDCM24X



#25 橡皮障夹 (无翼)

不锈钢

RDCM25

黑金系列

RDCM25X



#27 橡皮障夹

不锈钢

RDCM27

黑金系列

RDCM27X



#56 橡皮障夹

不锈钢

RDCM56

黑金系列

RDCM56X



#56S 橡皮障夹

不锈钢

RDCM56S

黑金系列

RDCM56SX



上颌磨牙橡皮障夹

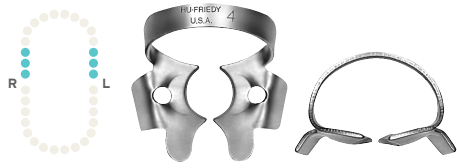

#4 橡皮障夹

不锈钢

RDCM4

黑金系列

RDCM4X



#W4 橡皮障夹

不锈钢

RDCMW4

黑金系列

RDCMW4X



#8 橡皮障夹

不锈钢

RDCM8

黑金系列

RDCM8X



#26N 橡皮障夹

不锈钢

RDCM26N

黑金系列

RDCM26NX



#201 橡皮障夹

不锈钢

RDCM201

黑金系列

RDCM201X

下颌磨牙橡皮障夹



#7 橡皮障夹

不锈钢

RDCM7

黑金系列

RDCM7X



#7A 橡皮障夹

不锈钢

RDCM7A

黑金系列

RDCM7AX



#12A 橡皮障夹

不锈钢

RDCM12A

黑金系列

RDCM12AX



#13A 橡皮障夹

不锈钢

RDCM13A

黑金系列

RDCM13AX

橡皮障辅助工具



Ainsworth 橡皮障打孔器
6.75" (17.5cm) **RDPA**

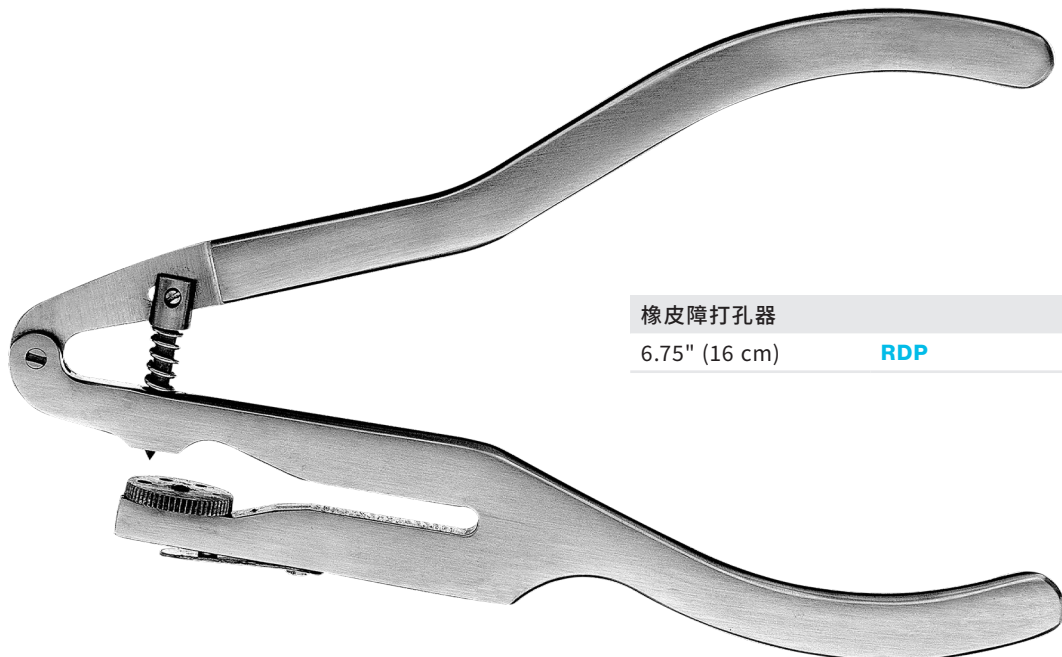

橡皮障打孔器
6.75" (16 cm) **RDP**

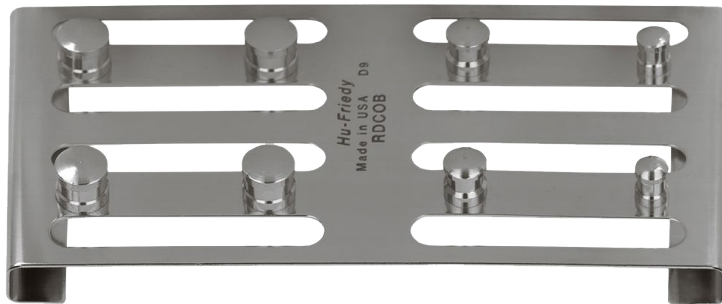

橡皮障夹消毒架

4.62" x 2.4" x .375" (117 mm x 61 mm x 10 mm) **RDCOB**

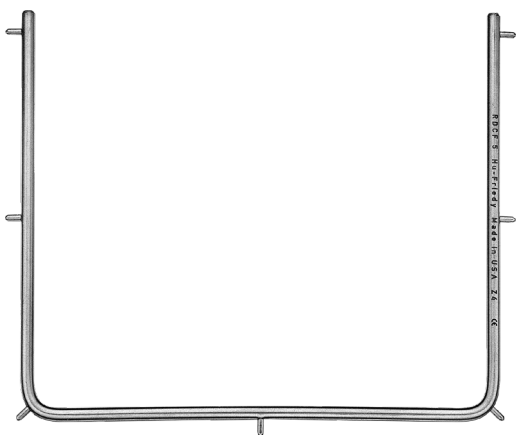

面弓

儿童- 5" (13 cm)

RDCF5



面弓

成人- 6" (15 cm)

RDAF6

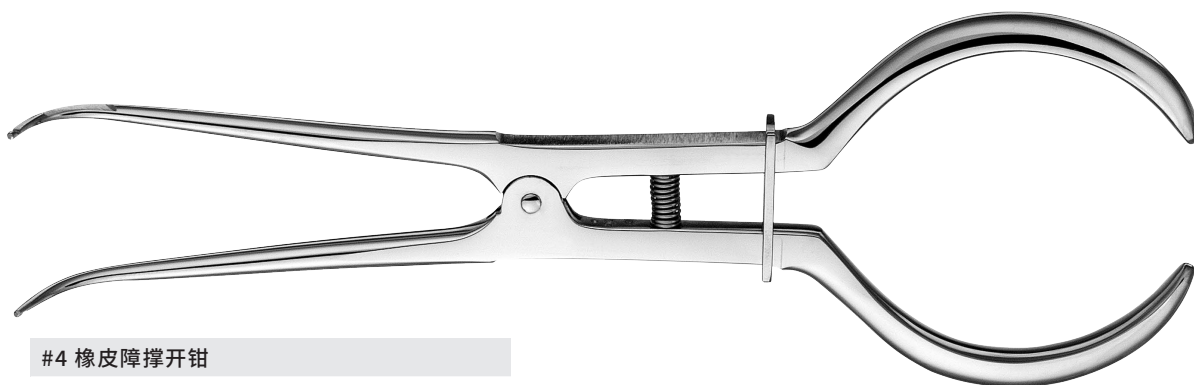

#4 橡皮障撑开钳

7" (17.5 cm)

RDF4



橡皮障撑开钳

6.5" (17 cm)

RDF

橡皮障布

橡皮障布使用中等模量的天然乳胶制成，无粉末-每片低于5mg(ASTM D6124:2001)。低蛋白-可提取蛋白含量低于FDA要求的50µg/g/片 (ASTM D5712: 1995)。抗撕拉能力强，100%不含氯。提供2种尺寸和3种厚度，并有非乳胶类橡皮障可供选择，以降低过敏反应的风险。

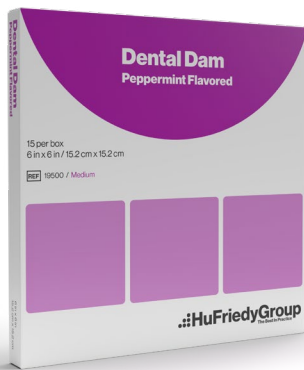

橡皮障布

非乳胶, 无粉末/低蛋白含量, 薄荷味
成人款 6"x 6", 15片/包

中 **19500**

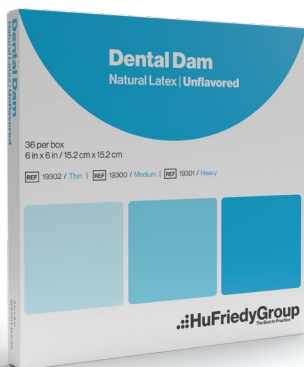

橡皮障布

乳胶, 无粉末/低蛋白含量, 无味
儿童款 5"x 5", 52片/包

薄 **19102**

中 **19100**

厚 **19101**

成人款 6"x 6", 36片/包

薄 **19302**

中 **19300**

厚 **19301**

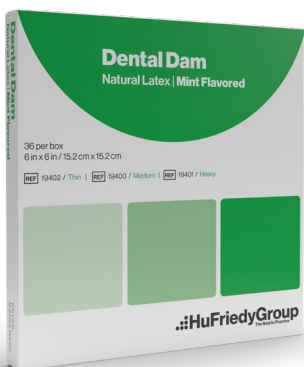

橡皮障布

乳胶, 无粉末/低蛋白含量, 薄荷味
儿童款 5"x 5", 52片/包

薄 **19202**

中 **19200**

厚 **19201**

成人款 6"x 6", 36片/包

薄 **19402**

中 **19400**

厚 **19401**



根尖手术器械

金属口镜



1 小号矩形口镜

2 x 7 mm

高抛光不锈钢

MM1

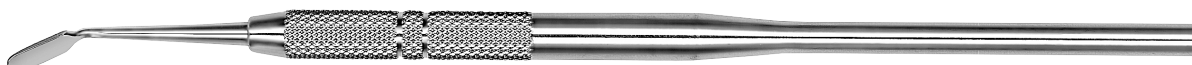

2 中号矩形口镜

3 x 9 mm

高抛光不锈钢

MM2



3 大号矩形口镜

4 x 12 mm

高抛光不锈钢

MM3

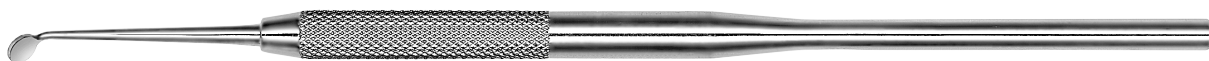

大号圆形口镜

4.5 mm

高抛光不锈钢

MMR



小号圆形口镜

2.5 mm

高抛光不锈钢

MMRS



#1 Velvart 双头矩形显微口镜

3 x 6mm; 2 x 6mm

高抛光不锈钢, #6号柄 **MMVEL1**



#2 Velvart 双头圆形显微口镜

3.5 mm; 3.5 mm

高抛光不锈钢, #6号柄 **MMVEL2**

显微口镜



显微圆形口镜 3 mm

MM4



显微圆形口镜 5 mm

MM5



显微矩形口镜 2 x 7 mm

MM7



显微矩形口镜 3 x 9 mm

MM8



#7 显微手术口镜/刀柄

10-130-70

根尖区刮匙—直杆

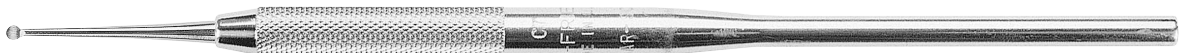

#1 Abou-Rass 显微外科刮匙, 单头

1.5 mm

#40号柄

MAR-SC1



#2 Abou-Rass 显微外科刮匙, 单头

2.5 mm

#40号柄

MAR-SC2



#3 Abou-Rass 显微外科刮匙, 单头

3 mm

#40号柄

MAR-SC3



#4 Abou-Rass 显微外科刮匙, 单头

4 mm

#40号柄

MAR-SC4



根尖挖匙—弯曲杆



#1 Abou-Rass 显微根尖挖匙, 双头
1 mm
#41 号柄 **MAR-C1**



#2 Abou-Rass 显微根尖挖匙, 双头
2 mm
#41 号柄 **MAR-C2**

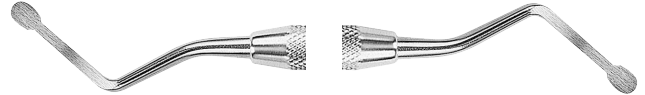

#3 Abou-Rass 显微根尖挖匙, 双头
3.2 mm
#41 号柄 **MAR-C3**



#4 Abou-Rass 显微根尖挖匙, 双头
4 mm
#41 号柄 **MAR-C4**

充填器



#0.5 Abou-Rass 直角显微充填器
0.5 mm / 0.6 mm
#41 号柄 **MAR-SAC.5**



#1 Abou-Rass 直角显微充填器
0.8 mm / 0.8 mm
#41 号柄 **MAR-SAC1**



#1.5 Abou-Rass 直角显微充填器
1.5 mm / 1.5 mm
#41 号柄 **MAR-SAC1.5**



#2 Abou-Rass 直角显微充填器
1.5 mm / 2.0 mm
#41 号柄 **MAR-SAC2**



#3 Abou-Rass 直角显微充填器
1.5 mm / 3.0 mm
#41 号柄 **MAR-SAC3**



充填/研磨器



大号左侧显微充填/研磨器

1.0 mm / 1.4 mm

#41 号柄

MCBLL



大号右侧显微充填/研磨器

1.0 mm / 1.4 mm

#41 号柄

MCBRL



中号右侧显微充填/研磨器

0.75 mm / 1.4 mm

#41 号柄

MCBRM



中号左侧显微充填/研磨器

0.75 mm / 1.4 mm

#41 号柄

MCBLM

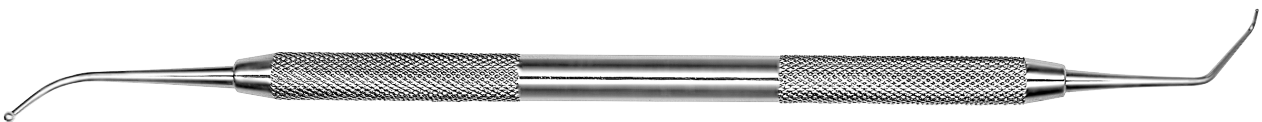

小号右侧显微充填/研磨器

0.50 mm / 1.4 mm

#41 号柄

MCBRS

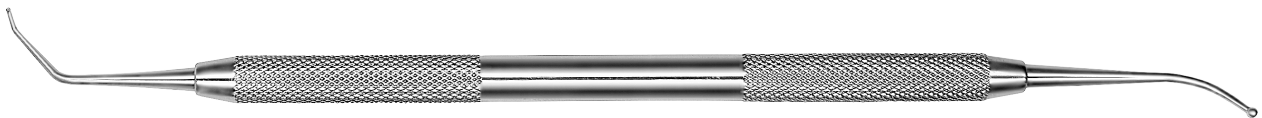

小号左侧显微充填/研磨器

0.50 mm / 1.4 mm

#41 号柄

MCBLS



倒充填器

显微倒充填器械适用于根尖手术操作



Micro-Retro 显微倒充填器 (左)

用于左侧的双端器械，可完成充填、填压以及抛光的作用。

#41 号柄

MRFL



Micro-Retro 显微倒充填器 (右)

用于右侧的双端器械，可完成充填、填压以及抛光的作用。

#41 号柄

MRFR



Khayat 根管充填器

这款多功能的Khayat充填器一端带有角度，另一端为一个直的铲形。适用于复杂且较深的根尖部位。

#6 号柄

PF18ABK6

显微根尖探针



显微探针，双头

#41 号柄

MEX1



1 Abou-Rass 显微根尖探针，双头

#33 号柄

MAR-EX1

探针

由特殊的合金材料制成，具有灵活性高、强度大、触觉敏感性好以及高弹性的特征。高效应用于临床的探查和评估工作中。



DG16 双头根管探针

#6 号柄

[EXDG166](#)

#7 号柄

[EXDG167](#)

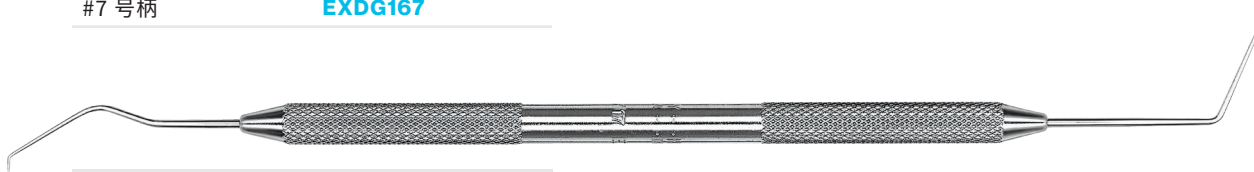

DG16/17 双头根管探针

#31 号柄

[EXDG16/17](#)



DG16/23 双头根管探针

#31 号柄

[EXDG16/23](#)

根管挖匙



2 Glick 双头根管挖匙
1.5 mm
#41 号柄 **EXCGL2**



#31L 双头根管挖匙
1 mm
#6 号柄 **EXC31L6**



#31W 双头椭圆勺型根管挖匙
1.3 mm
#6 号柄 **EXC31W6**



#32L 双头根管挖匙
1.5 mm
#6 号柄 **EXC32L6**



#33L 双头根管挖匙
2 mm
#6 号柄 **EXC33L6**

侧方加压充填器



1S Wakai 侧方加压充填器, 单头
尖端0.30 mm, 长22 mm
#40 号柄 **RCSW1S**



D11S 侧方加压充填器, 单头
尖端0.35 mm, 长23 mm
#40 号柄 **RCSD11S**



D11 侧方加压充填器, 单头
尖端0.40 mm, 长23 mm
#40 号柄 **RCSD11**



D11T 侧方加压充填器, 单头
尖端0.23 mm, 长22 mm
#40 号柄 **RCSD11T**



D11TS 侧方加压充填器, 单头
尖端0.20 mm, 长21 mm
#40 号柄 **RCSD11TS**



镍钛侧方加压充填器

镍钛材料的高弹性和记忆功能提高了器械的操控性。同时带有颜色的手柄提高了辨识度和区分度。

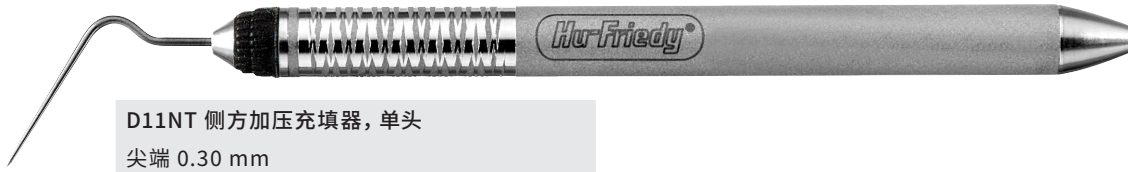

D11NT 侧方加压充填器, 单头
尖端 0.30 mm
#7 号柄

RCS D11NT



D11TSNT 侧方加压充填器, 单头
尖端 0.25 mm
#7 号柄

RCS D11TSNT



25SNT 侧方加压充填器, 单头
尖端 0.25 mm
#7 号柄

RCS 25SNT



25NT 侧方加压充填器, 单头
尖端 0.25 mm
#7 号柄

RCS 25NT

垂直加压充填器



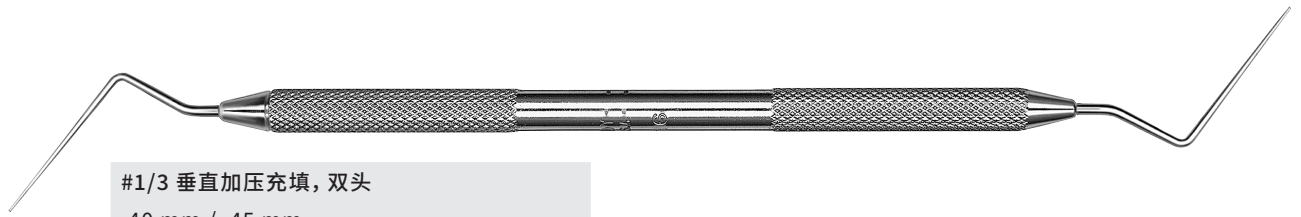

#1/3 垂直加压充填, 双头
.40 mm / .45 mm
#41 号柄 **RCP1/3**



#5/7 垂直加压充填器, 双头
.50 mm / .75 mm
#41 号柄 **RCP5/7**

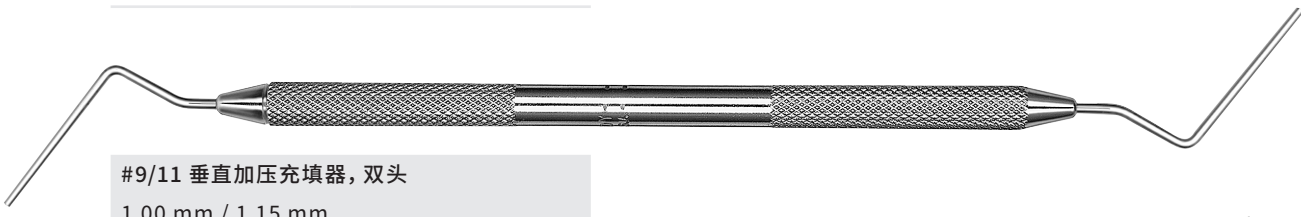

#9/11 垂直加压充填器, 双头
1.00 mm / 1.15 mm
#41 号柄 **RCP9/11**



#1/2 Machtou 垂直加压充填器, 双头
.50 mm / .60 mm
#41 号柄 **RCPM1/2**

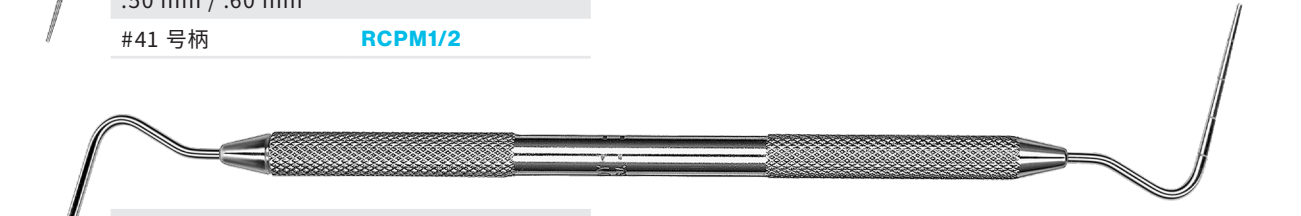

#3/4 Machtou 垂直加压充填器, 双头
.80 mm / 1.10 mm
#41 号柄 **RCPM3/4**



#1 Glick 垂直加压充填器, 双头
#41 号柄 **RCPGL1**



根管镊

根管桩/银针镊



Steiglitz 取根管桩镊, 工作端直
14 cm **RFSTR**

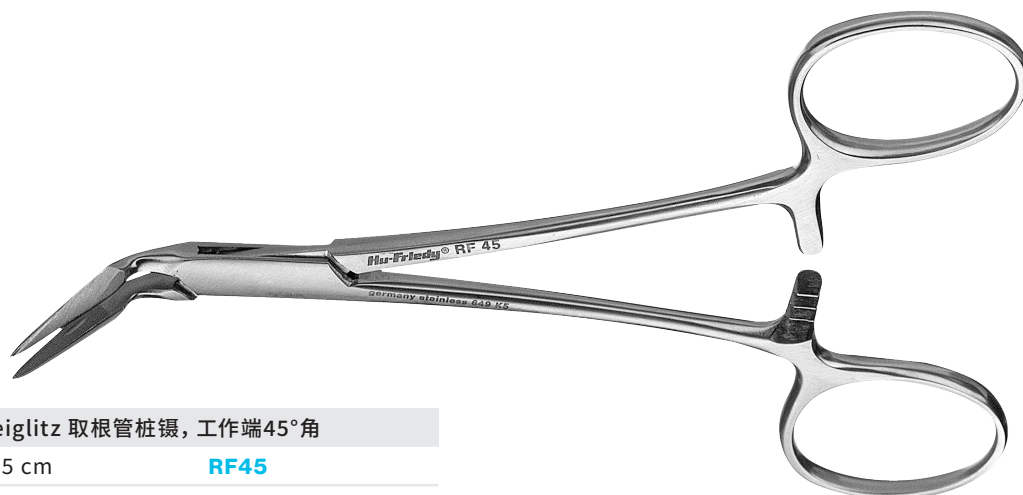

Steiglitz 取根管桩镊, 工作端45°角
13.5 cm **RF45**



Steiglitz 取根管桩镊, 工作端90°角
12 cm **RF90**



Peet 取银针镊, 工作端45°角
12 cm **RFP**

尺子



不锈钢尺
15.24 cm **CLR6**

锁镊



牙胶尖镊

16.5 cm

EPL1

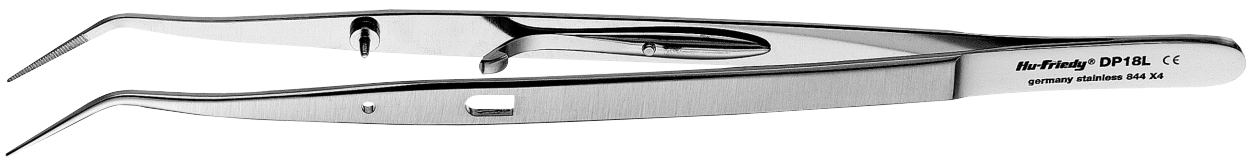

#18 号锁镊

DP18L

套装	A602
手柄	A603
树脂修复类器械	A604
制备/修整器	A607
刮匙	A608
勺形	A608
椭圆形	A609
英式	A609
放置器械	A610
咬合纸夹持镊	A611
雕刻刀	A612
水门汀去除器	A613
塑形抛光器	A614
推龈器	A615
排龈线器	A616
取冠器	A617
美学器械	A618
调拌刀	A618
美学比例尺	A619

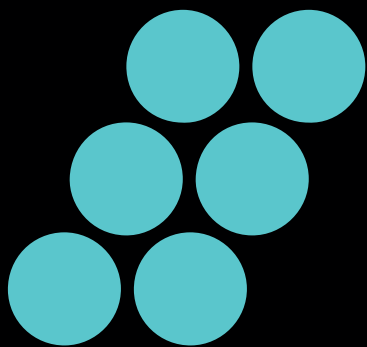

修复类器械

套装



Dietschi 美学树脂充填套装 金属柄 **PFIDDCASS**

1/2 Dietschi 充填器 **PFIDD1/2**

3/4 Dietschi 充填器 **PFIDD3/4**

5/6 Dietschi 充填器 **PFIDD5/6**

7/8 Dietschi 充填器 **PFIDD7/8**

9/10 Dietschi 充填器 **PFIDD9/10**

5支装器械盒, 橘色 **IM6053**

Dietschi 美学树脂充填套装 #8树脂柄 **PFIDDCASS8**

1/2 Dietschi 充填器 **PFIDD1/28**

3/4 Dietschi 充填器 **PFIDD3/48**

5/6 Dietschi 充填器 **PFIDD5/68**

7/8 Dietschi 充填器 **PFIDD7/88**

9/10 Dietschi 充填器 **PFIDD9/108**

5支装器械盒, 橘色 **IM6053**

手柄

双头



单头





树脂修复类器械

器械表面附有氧化氮涂层，形成的坚硬且光洁的表面有效的避免划伤以及材料黏连。轻量级手柄易于清理，同时提供最大的舒适性和可操控性。树脂充填器械，具有薄，弹性好，表面光洁，材料与器械不黏连 的特点，可用于树脂材料的充填和塑形。



Akro-Flex™ 树脂充填器

光滑

AKRO-FLEX



#1 Goldstein 超薄弹性充填器

XTS™

TNCIGFT1



#2 Goldstein 超薄弹性充填器

XTS™

TNCIGFT2

#41 号柄

CIGFT2



#3 Goldstein 超薄超弹充填器

XTS™

TNCIGFT3

#41 号柄

CIGFT3



#4 Goldstein 超薄超弹充填器

XTS™

TNCIGFT4



#5 Goldstein 超薄弹性充填器

XTS™ **TNCIGFT5**

#41 号柄 **CIGFT5**



#6 Goldstein 超薄弹性充填器

XTS™ **TNCIGFT6**



微型树脂充填器

XTS™ **TNCIPCS**



#1 微型树脂充填器

XTS™ **TNCIGFTMI1**



#3 微型超弹树脂充填器

XTS™ **TNCIGFTMI3**



#4 微型超弹树脂充填成型器

XTS™ **TNCIGFTMI4**

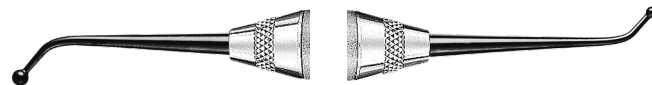

中/大号球形充填器

XTS™ **TNBB18**



AB2 Boghosian 树脂充填器

XTS™ **TNPFIAB2**

#41 号柄 **PFIAB2**



8A 树脂充填器

XTS™ **TNPF18A**



间隙塑形器

XTS™ **TNCVIPC**



A6 树脂充填器

XTS™ **TNPFIA6**



21B 树脂充填器

XTS™ **TNBB21B**



27/29 树脂充填器

XTS™ **TNBB27/29**

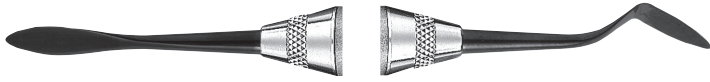

B 美学塑形器

XTS™

TNCCIB

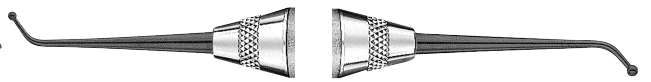

小/中号球形充填器

XTS™

TNBBS/M



D 美学塑形器

XTS™

TNCCID

#10 号柄

CCID

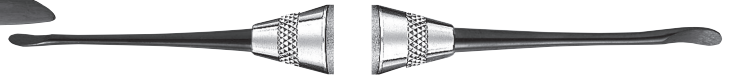

E 美学塑形器

XTS™

TNCCIE



F 美学塑形器

XTS™

TNCCIF



G 边缘峭塑形器

XTS™

TNCCIG



#1 Loesche 树脂充填器

#41 号柄

PFIGML1



1/2 Dietschi 充填器

不锈钢手柄

PFIDD1/2

#8 号树脂柄

PFIDD1/28



3/4 Dietschi 充填器

不锈钢手柄

PFIDD3/4

#8 号树脂柄

PFIDD3/48



5/6 Dietschi 充填器

不锈钢手柄

PFIDD5/6

#8 号树脂柄

PFIDD5/68



7/8 Dietschi 充填器

不锈钢手柄

PFIDD7/8

#8 号树脂柄

PFIDD7/88

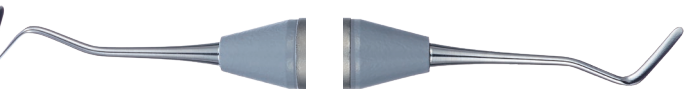

9/10 Dietschi 充填器

不锈钢手柄

PFIDD9/10

#8 号树脂柄

PFIDD9/108

制备/修整器

用于洞型的预备：固位形和线角的制备以及龋坏组织的清除。



8/9H 斧形制备器

[10-7-14]

#6 号柄

CP8/9H6

#9 号柄

CP8/9H9



17/18 斧形制备器

[10-6-14]

#6 号柄

CP17/186



3/4 Wedelstaedt 凿

[11.5-15-3]

#41 号柄

CP3/4



28 远中肩台修整器

[10-95-7-14]

#6 号柄

MT286



29 近中肩台修整器

[10-80-7-14]

#6 号柄

MT296

刮匙

用于清除龋坏组织

勺形



E1 刮匙	
1.2 mm [12-9-15]	
#6 号柄	EXCE16
#41 号柄	EXCE1



17 刮匙	
1.2 mm	
#6 号柄	EXC176



18 刮匙	
1.5 mm	
#6 号柄	EXC186



19 刮匙	
2.0 mm	
#41 号柄	EXC19
#6 号柄	EXC196



椭圆形



17W 刮匙
1.2 mm
#41 号柄 **EXC17W**

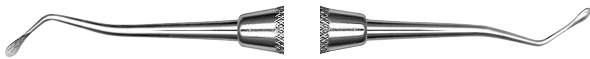

18W 刮匙
1.5 mm
#41 号柄 **EXC18W**



19W 刮匙
1.8 mm
#41 号柄 **EXC19W**

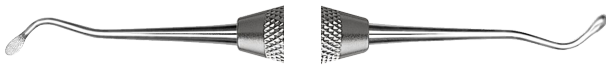

220/221 Darby-Perry 刮匙
1.5 mm
#6 号柄 **EXC220/16**
#41 号柄 **EXC220/1**

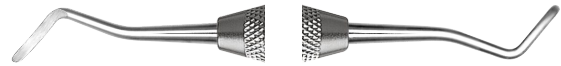

36/37 刮匙
1.5 mm [15-8-14]
#6 号柄 **EXC36/376**
#41 号柄 **EXC36/37**

英式



Goldstein 间隙刮匙
1.2 mm
#9 号柄 **EXC2429**
#41 号柄 **EXC242**



243 刮匙
1.0 mm
#41 号柄 **EXC243**



246 刮匙
0.8 mm
#6 号柄 **EXC2466**
#9 号柄 **EXC2469**
#41 号柄 **EXC246**

放置器械

用于放置垫底材料



氢氧化钙充填器

- | | |
|--------|--------------|
| #6 号柄 | PICH6 |
| #41 号柄 | PICH |



通用放置器/小型调拌刀

- | | |
|--------|----------------|
| #6 号柄 | SP60616 |
| #41 号柄 | SP6061 |

咬合纸夹持镊

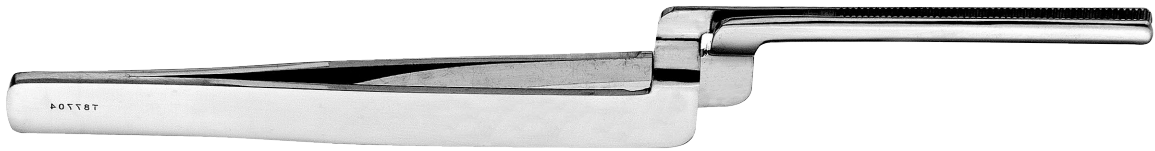

咬合纸夹持镊

APF2



雕刻刀

用于解剖形态的雕刻和多余材料的去除。钨钢材质的工作端适用于所有树脂材料，形态多样，防划伤且不会褪色。也是正畸去除托槽粘接剂的理想工具。



8 Wiland 雕刻刀

#6 号柄

CVWI86



1 Hollenback 雕刻刀

#41 号柄

CVHL1



2 Hollenback 雕刻刀

#41 号柄

CVHL2

水门汀去除器

用于去除多余的充填材料



20 美学水门汀去除器 (前牙)

#6 号柄

CR206



21 美学水门汀去除器 (后牙)

#6 号柄

CR216



Edentulous 峭齿(#36 金箔雕刻刀)

#40 号柄

GF36



12 Novatech 水门汀去除器

#41 号柄

CRNT12



塑形抛光器

用于银汞合金充填材料的压紧，
塑形和抛光。



18 塑形抛光器
2.4 mm / 1.6 mm
#6 号柄

BB186



26/27S 塑形抛光器
2.1 mm / 1.3 mm
#6 号柄

BB26/27S6



27/29 塑形抛光器
3.1 mm / 1.6 mm
#6 号柄

BB27/296



21B 塑形抛光器
3.0 mm / 2.7 mm
#6 号柄

BB21B6

推龈器

新月形工作端设计能够与牙龈组织和根面相匹配。在树脂充填抛光或橡皮障放置过程中起到辅助作用。



Kincheloe 推龈器

#41 号柄

GRK1



1 Meinershagen 推龈器

#41 号柄

GRM1

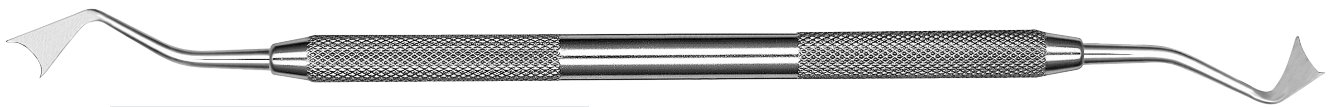

2 Meinershagen 推龈器

#41 号柄

GRM2

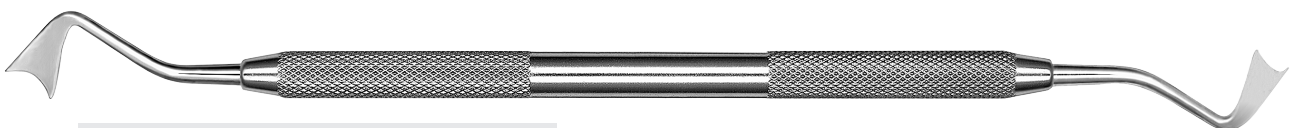

3 Meinershagen 推龈器

#41 号柄

GRM3



4 Meinershagen 推龈器

#41 号柄

GRM4

排龈线器

无创且精准的放置排龈线。当使用编织线时可选择含锯齿的排龈线器。



113 排龈线器, 带齿
#6 号柄 **GCP1136**



113 排龈线器, 无齿
#6 号柄 **GCP113NS6**



S6 排龈线器
#6 号柄 **GCP66**



Balshi 排龈线器
#41 号柄 **GCPBAL**



1 Yardley 排龈线器
#6 号柄 **GCPYD16**

取冠器

使用车针在牙齿和冠打开切口，
然后使用取冠器移除牙冠。

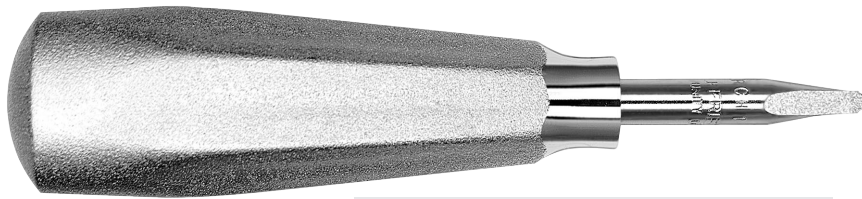

Christensen 取冠器 (前牙)

CRCH1

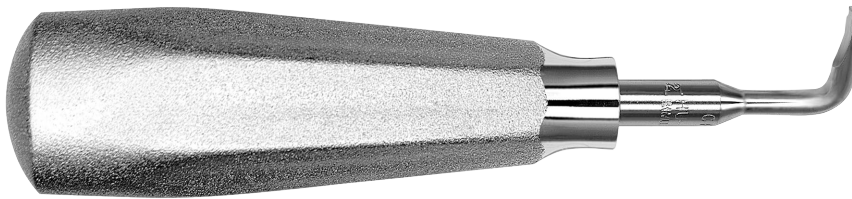

Christensen 取冠器 (后牙)

CRCH2



Goldstein 取冠器 (45° T型柄)

GCR45



Goldstein 取冠器

GCROS



美学器械

设计用于精准的美学测量



Nash/Taylor 贴面粘接辅助器械
#6 号柄 **VENSTAB**



Nash/Taylor 贴面粘接辅助器械
#6 号柄 **VENSTABS**



Nash/Taylor 嵌体/高嵌体器械
#6 号柄 **IL/OL**

调拌刀

用于材料混合, 技工室日常使用



调拌刀
1 3/4" (44 mm)
#6 号柄 **CS246**

美学比例尺



牙冠比例尺

1 个手柄, 2 个T形工作端, 2个内置工作端

XTS柄

PROGS

牙冠比例尺

1 个手柄, 2 个T形工作端, 2个内置工作端

#8 号柄

PROG



冠延长尺

1 个手柄, 2 个BLPG工作端, 2 个Papilla工作端

XTS柄

CLGS

冠延长尺

1 个手柄, 2 个 BLPG 工作端, 2 个 Papilla工作端

#8 号柄

CLG



牙槽嵴测量尺

XTS柄

SOUNDGS

牙槽嵴测量尺

#8 号柄

SOUNDG

Clear Collection™ 系列隐形矫正钳	A702
切断钳	A703
功能钳	A705
舌侧正畸钳	A707
弯制钳	A709
Mathieus 系列持针钳	A712
辅助器械	A713
辅件	A715

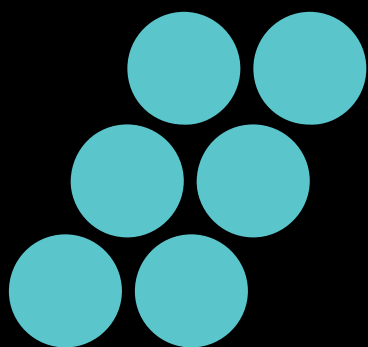

正畸类器械

Clear Collection™ 系列隐形矫正钳

Clear Collection™系列隐形矫正钳，创新型设计无需额外加热，适用于隐形矫治。



泪滴钳
678-800



垂直钳
678-801

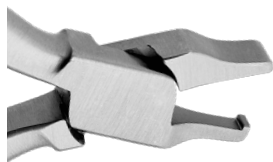

水平钳
678-802

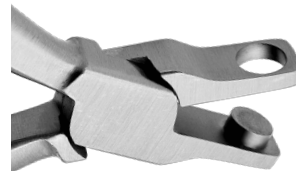

打孔钳, 6 mm
678-803



压力点钳
678-804



打孔钳, 4.5 mm
678-805



逆时楔形转矩钳
678-807



顺时楔形转矩钳
678-808

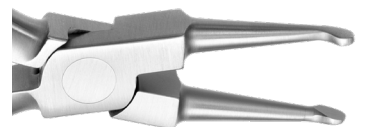

消痕钳
678-811

切断钳

采用专利技术，严格遵守质量标准要求。让器械在任何时候都能保持高精度的切割功效。

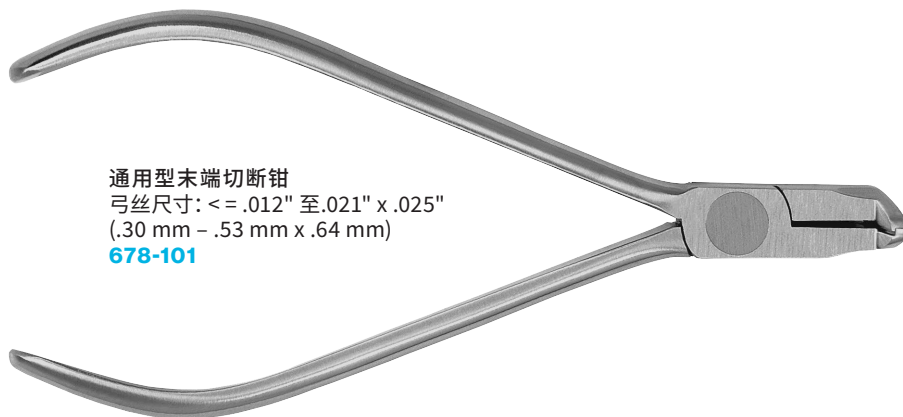

通用型末端切断钳
弓丝尺寸: $\leq .012''$ 至 $.021'' \times .025''$
(.30 mm - .53 mm x .64 mm)
678-101



通用型末端切断钳 (加长柄)
弓丝尺寸: $\leq .012''$ 至 $.021'' \times .025''$
(.30 mm - .53 mm x .64 mm)
678-101L

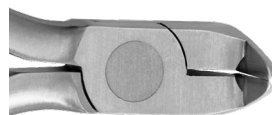

末端切断钳
弓丝尺寸: $\leq .021'' \times .025''$
(.53 mm x .64 mm)
678-102

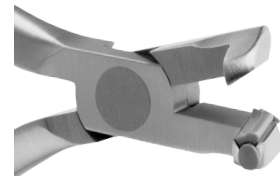

末端切断钳
弓丝尺寸: $\leq .020''$ (.51 mm)
678-111



硬弓丝切断钳 (15°)
15°偏移钳尖, 硬弓丝尺寸:
 $\leq .022'' \times .028''$ (.56 mm x .71 mm)
678-103

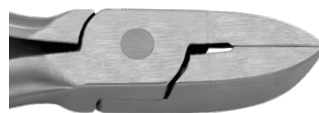

硬弓丝切断钳
硬弓丝尺寸: $\leq .022'' \times .028''$
678-104

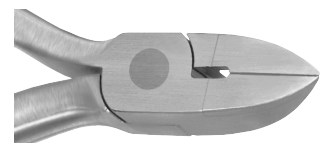

多功能切断钳
弓丝或结扎丝尺寸:
 $\leq .015''$ (.38 mm)
678-105



切断钳



迷你切断钳
软弓丝引针和结扎丝尺寸：
<= .012" (.30mm)
678-106

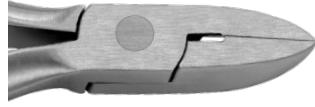

迷你切断钳
软弓丝引针和结扎丝尺寸：
<= .012" (.30mm)
678-107



迷你切断钳 (加长柄)
软弓丝引针和结扎丝尺寸：
<= .012" (.30mm)
678-107L

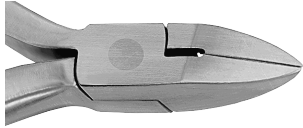

超迷你切断钳 (15°)
结扎丝尺寸: <= .012" (.30 mm)
678-109

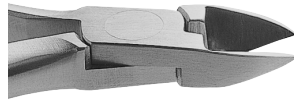

微型切断钳
软弓丝引针和结扎丝尺寸：
<= .012" (.30 mm)
678-110



细丝切断钳
软弓丝引针和结扎丝尺寸：
<= .008" to .012" (.20 mm to .30 mm)
678-500

功能钳



超薄温氏钳
弓丝尺寸: $\leq .030''$ (.76 mm)
678-200



温氏钳
弓丝尺寸: $\leq .030''$ (.76 mm)
678-501

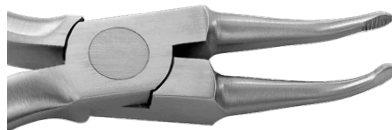

霍氏钳
弓丝尺寸: $\leq .030''$ (.76 mm)
678-204



粘合剂去除钳
678-206

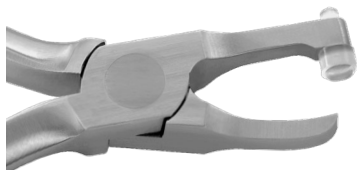

带环去除钳 (长头)
678-207



带环去除钳 (短头)
678-208



带环去除钳
678-503

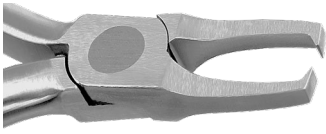

托槽去除钳
678-219

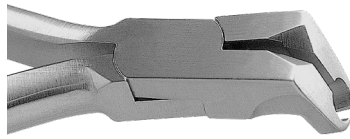

角度托槽去除钳
678-220L

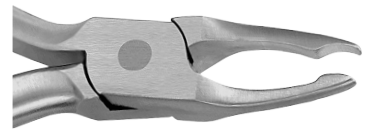

牙冠或带环塑形钳
678-221

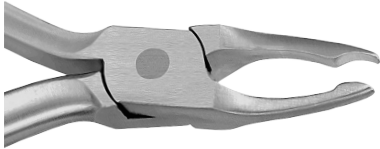

超薄牙冠或带环塑形钳
678-221M

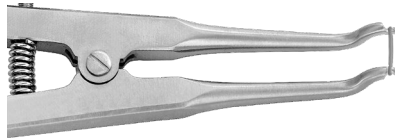

分牙圈放置钳
678-210

卷边钳
678-225



舌侧正畸钳



舌侧末端切断钳
弓丝尺寸: .012"-.018"
(.30 mm-.46 mm)

678-700



舌侧细丝切断钳
软弓丝引针和结扎丝尺寸:
<= .012" (.30 mm)

678-701



舌侧温氏钳
弓丝尺寸: <= .030" (.76 mm)

678-702



舌侧温氏钳 (90°)
弓丝尺寸: <= .030" (.76 mm)

678-702-90



舌侧托槽去除钳
678-703



Hammerhead® 舌侧镍钛丝末端回弯钳,含锯齿
弓丝尺寸: $\leq .025"$ (.64mm)
678-704SER



舌侧持针钳
结扎丝尺寸: $\leq .015"$ (.38mm)
678-705

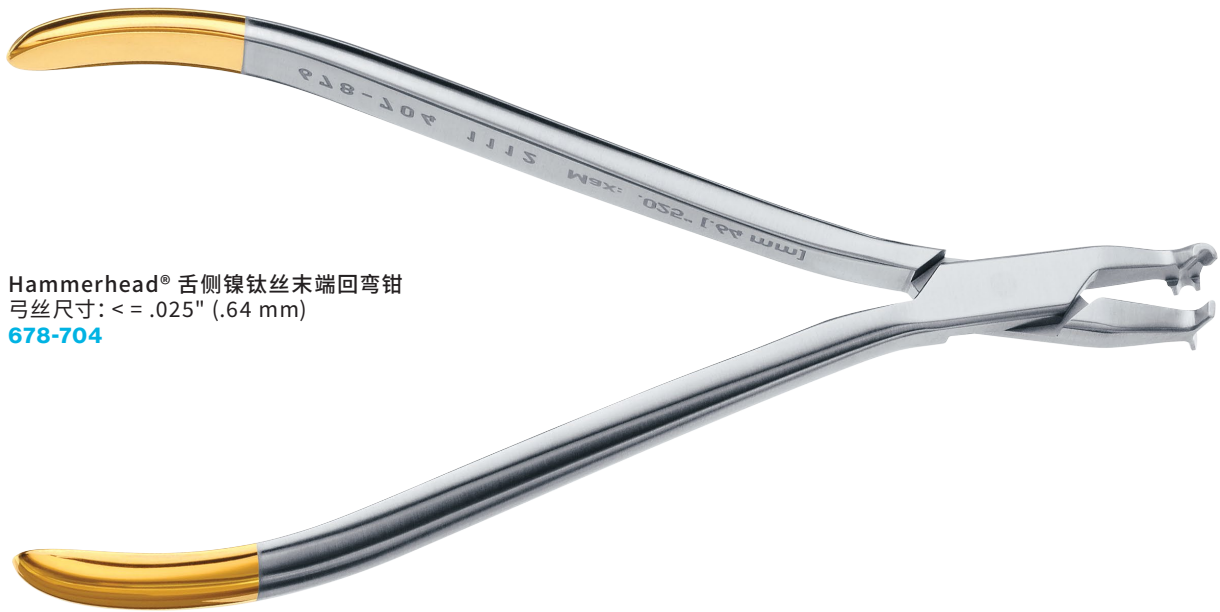

Hammerhead® 舌侧镍钛丝末端回弯钳
弓丝尺寸: $\leq .025"$ (.64 mm)
678-704

弯制钳

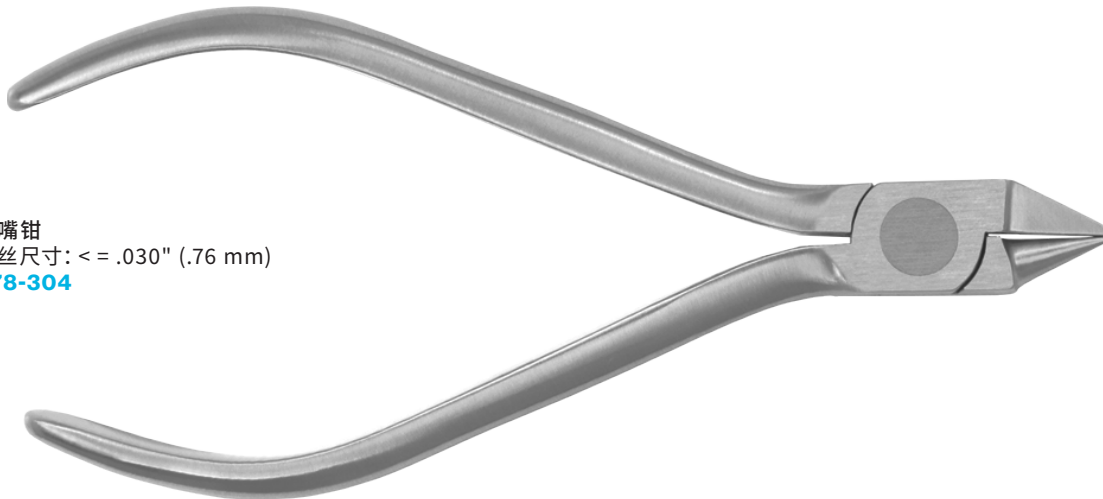

鸟嘴钳
弓丝尺寸: $\leq .030"$ (.76 mm)
678-304

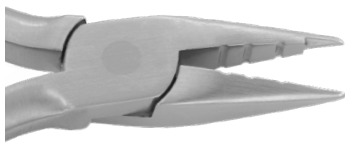

Jarabak钳
弓丝尺寸: $\leq .020"$ (.51 mm)
678-301



Omega 钳
弓丝尺寸: $\leq .022" \times .025"$
(.56 mm x .64 mm)
678-303

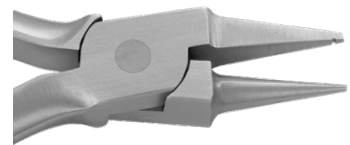

长鸟嘴钳, 带槽 / 长鸟嘴钳
弓丝尺寸: $\leq .020"$ (.51 mm)
678-305/678-318

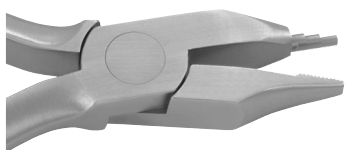

Tweed 成形钳
弓丝尺寸: $\leq .022" \times .028"$
(.56 mm x .71 mm)
678-306

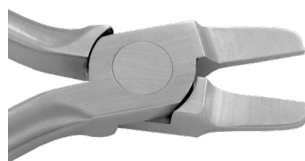

弓丝弯制钳
弓丝尺寸: $\leq .022" \times .028"$
(.56 mm x .71 mm)
678-307

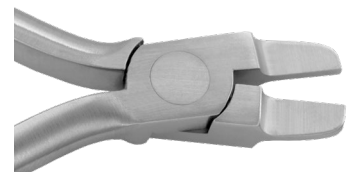

转矩钳
弓丝尺寸: $\leq .022" \times .028"$
(.56 mm x .71 mm)
678-308



舌弓成形钳
弓丝尺寸: $\leq .036"$ (.91 mm)
678-309



O'Brien 钳
弓丝尺寸: $\leq .020"$ (.51 mm)
678-311



三叉钳
弓丝尺寸: $\leq .030"$ (.76 mm)
678-312

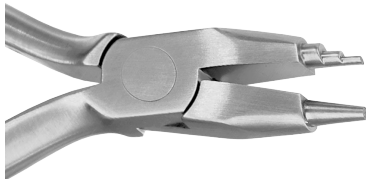

Marcotte圈环钳
弓丝尺寸: $\leq .022" \times .028"$
(.56 mm x .71 mm)
678-316

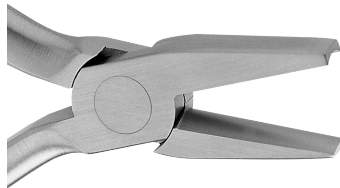

弓丝弯制钳
弓丝尺寸: $\leq .030"$ (.76 mm)
678-317



Nance成形钳
弓丝尺寸: $\leq .022"$ (.53 mm)
678-319



Adams钳
弓丝尺寸: $\leq .040"$ (1.01 mm)
678-320

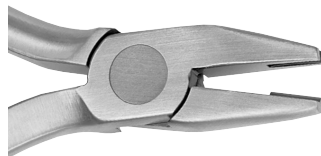

V型弯钳
弓丝尺寸: $\leq .022" \times .028"$
(.56 mm x .71 mm)
678-321

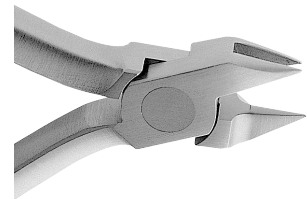

三叉钳 (镍钛丝弯制)
弓丝尺寸: $\leq .020"$ (.51 mm)
678-322

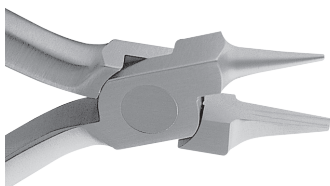

日月钳
弓丝尺寸: $\leq .022" \times .028"$
(.56 mm x .71 mm)
678-323

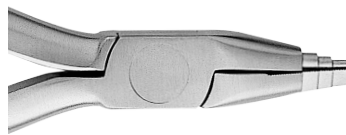

老式圈环钳
弓丝尺寸: $\leq .022" \times .028"$
(.56 mm x .71 mm)
678-324

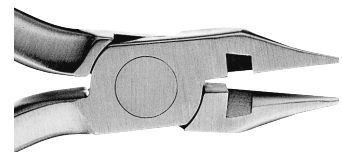

鸟嘴切断钳
弓丝尺寸: $\leq .022" \times .028"$
(.56 mm x .71 mm)
678-325

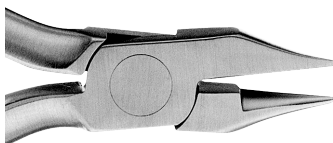

长锥形鸟嘴钳
弓丝尺寸: $\leq .022" \times .028"$
(.56 mm x .71 mm)
678-326

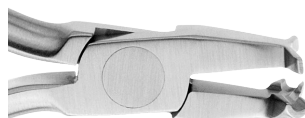

Hammerhead®镍钛丝回弯钳
弓丝尺寸: $\leq .025"$ (.64 mm)
678-327



Hammerhead®镍钛丝回弯钳
弓丝尺寸: $\leq .025"$ (.64 mm)
678-502

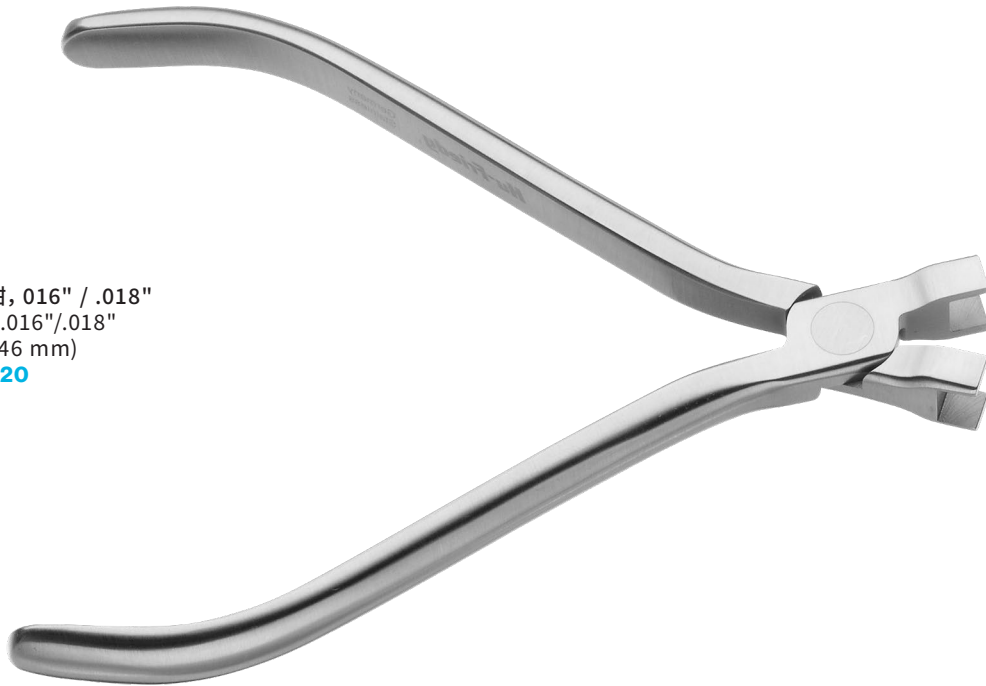

方丝转矩钳, 016" / .018"
弓丝尺寸: .016"/.018"
(.41 mm/.46 mm)
678-328-20



方丝转矩钳, 019" / .022"
弓丝尺寸: .019"/.022"
(.46 mm/.56 mm)
678-328-21

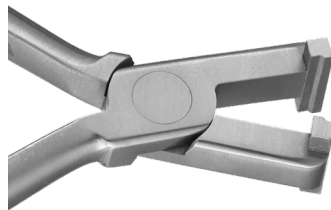

方丝转矩钳, 1/2mm
弓丝尺寸: .020" (1/2 mm)
678-340

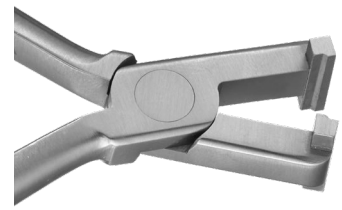

方丝转矩钳, 3/4mm
弓丝尺寸: .030" (3/4 mm)
678-341

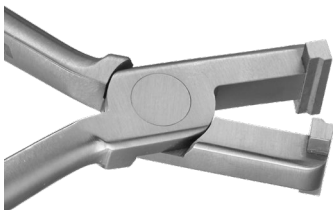

方丝转矩钳, 1mm
弓丝尺寸: .039" (1 mm)
678-342



Mathieus 系列持针钳

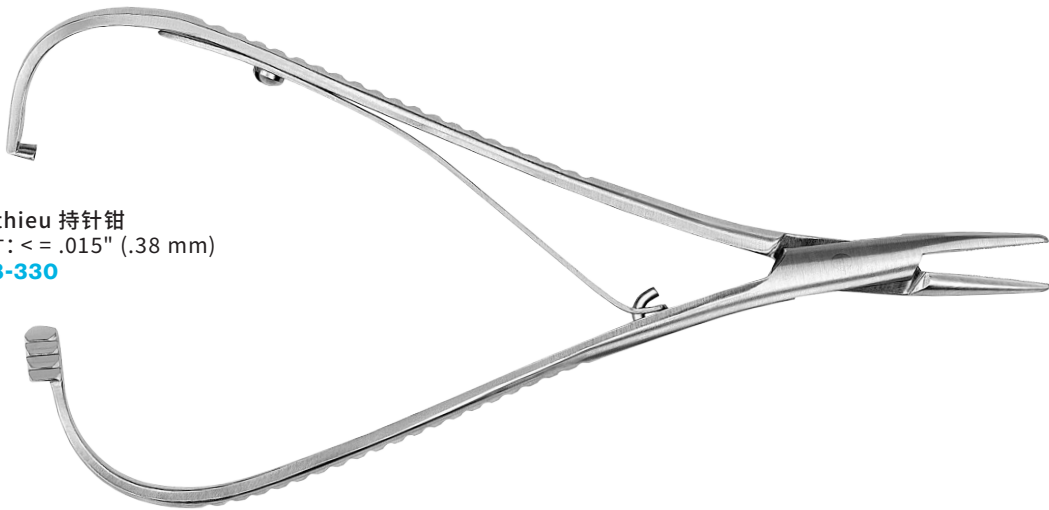

Mathieus 持针钳
尺寸: $\leq .015"$ (.38 mm)
678-330



Mathieus 持针钳, Wide Tip
尺寸: $\leq .015"$ (.38 mm)
678-331



Mathieus 持针钳, Perma Sharp™
尺寸: $\leq .015"$ (.38 mm)
678-332

辅助器械

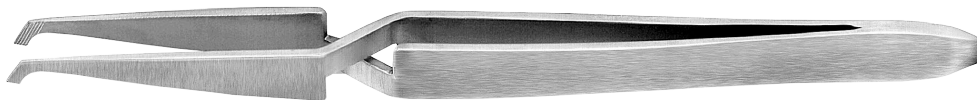

托槽镊
678-212

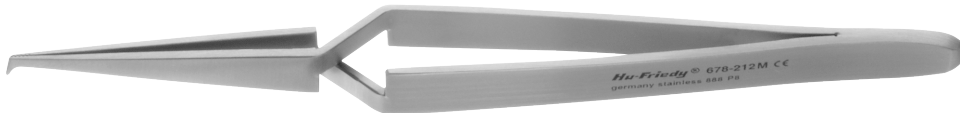

托槽镊
678-212M



托槽镊
678-504



颊面管镊
678-505



弓丝末端回弯器
弓丝尺寸: $\leq .021'' \times .025''$ (.53 mm x .64 mm)
678-506



洁治器/带环推
678-904



洁治器/结扎丝就位器
678-905



带环推/洁治器
678-906



小充填器/除橡皮圈钩
678-907



大充填器/除橡皮圈钩
678-909



结扎丝就位器/带环推
678-912



结扎丝就位器/除橡皮圈钩
678-916



带环推子
BP300



结扎丝就位器/充填器
LDP



舌侧结扎丝就位器
.018" (.46 mm)
TK018

辅件

678-206 替换刀片

数量: 1

678-001

678-113 硅胶插件

数量: 3

678-013

678-206 替换垫

数量: 6

678-014A

019" / .022" 转矩工作尖

数量: 1

678-021

678-111 硅胶插件

数量: 3

678-011

678-207, 678-208, 678-503 替换垫

数量: 6

678-014

678-303 替换螺丝和阶梯锥形工作尖

数量: 1

678-020

678-207, 678-208, 678-503 替换垫

数量: 6

678-036

吸唾器	A802
测量器	A804
骨凿	A805
外科刮匙	A810
牙挺	A815
骨锉	A824
牙周锉	A826
拔牙钳	A827
种植骨再生器械	A837
止血钳	A840
种植器械	A842
骨劈开/挤压器	A847
牙龈刀	A850
骨锤	A853
开口器	A853
橡胶咬合器	A854
持针器	A854
骨膜分离器	A861
牙龈分离器	A870
拉钩	A871
咬骨钳	A876
根尖挺	A880
手术刀柄	A884
手术剪	A887
注射类器械	A894
组织镊	A895
组织钳	A903

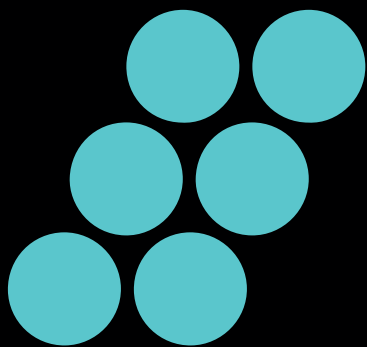

外科类器械

吸唾器



Kotschy 吸唾器 (13 cm)

ASKOT



Andrew-Pychon 吸唾器 (23 cm)
配有硅胶管转换接头

ASPA



B1 Byrd 自洁吸唾器 (21.5 cm)
配有硅胶管转换接头

1.5 mm

ASPB1

2 mm

ASPB2

2.5 mm

ASPB3



3 Cogswell 吸唾管 (24.3 mm)
配有硅胶管转换接头

ASPCG3



Coupland 吸唾器头 (9.2 cm)

- #1 Coupland 吸唾器头 (口径1.5 mm) **ASPCT1**
- #2 Coupland 吸唾器头 (口径2.0 mm) **ASPCT2**
- #3 Coupland 吸唾器头 (口径2.5 mm) **ASPCT3**
- #4 Coupland 吸唾器头 (口径3.0 mm) **ASPCT4**

Coupland 吸唾器头, 带孔 (9.2 cm)

- #1 Coupland 吸唾器头 (口径1.5 mm, 带孔) **ASPCT1W**
- #2 Coupland 吸唾器头 (口径2.0 mm, 带孔) **ASPCT2W**
- #3 Coupland 吸唾器头 (口径2.5 mm, 带孔) **ASPCT3W**
- #4 Coupland 吸唾器头 (口径3.0 mm, 带孔) **ASPCT4W**

Coupland 吸唾器手柄 (16.8 cm)

配有硅胶管转换接头 **ASPCH**



Frazier 吸唾器 (17.8 cm)

- 6 Frazier 吸唾器 (口径1.5 mm) **ASFR6**
- 8 Frazier 吸唾器 (口径2.0 mm) **ASFR8**
- 10 Frazier 吸唾器 (口径2.5 mm) **ASFR10**
- 12 Frazier 吸唾器 (口径3.0 mm) **ASFR12**



Pointius 吸唾管 (14.3 cm)
配有硅胶管转换接头

ASPON

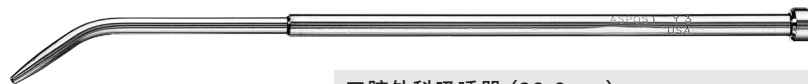

口腔外科吸唾器 (22.8 cm)
配有硅胶管转换接头

- 口腔外科吸唾器 (口径1 mm) **ASPOS1**
- 口腔外科吸唾器 (口径2 mm) **ASPOS2**
- 口腔外科吸唾器 (口径3 mm) **ASPOS3**
- 口腔外科吸唾器 (口径4 mm) **ASPOS4**



吸唾器转换接头

PTAA

测量器

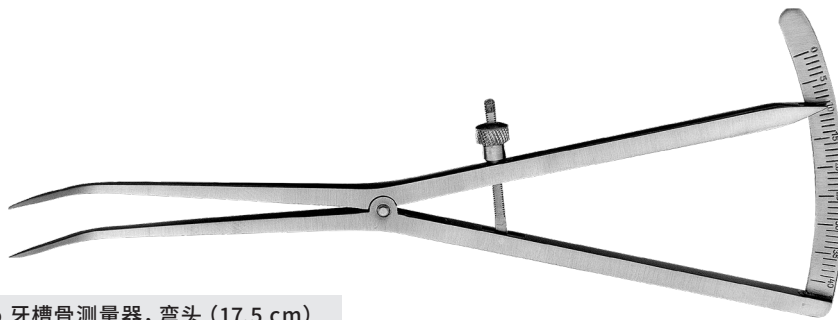

Castroviejo 牙槽骨测量器，弯头 (17.5 cm)
40 mm **CLC40C**

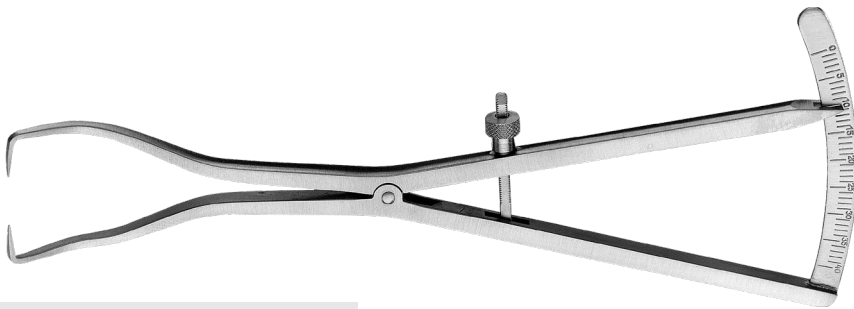

Weiss 改良牙槽骨测量器，弯头 (16.6 cm)
40 mm **CLC40CWM**

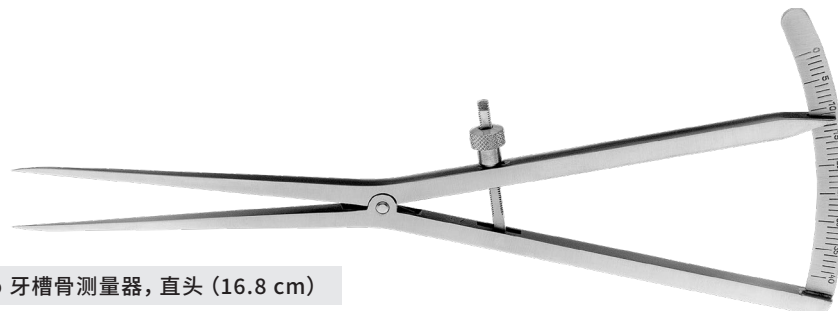

Castroviejo 牙槽骨测量器，直头 (16.8 cm)
40 mm **CLC40L**



骨凿

牙周骨凿



36/37 Back-Action 牙周骨凿
#9 号柄 **C36/379**
#6 号柄 **C36/376**



1/2 Kramer-Nevins 牙周骨凿
#6 号柄 **CKN1/26**

Ochsenbein 骨凿

主要用于骨平整，半圆形刃口方便切除软组织瓣



Och-1 Ochsenbein 牙周骨凿
#524 号柄 **CO1**

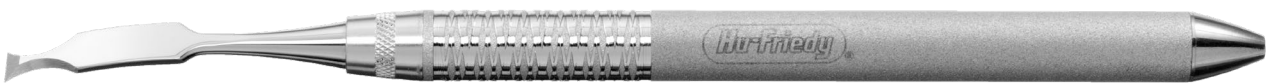

Och-2 Ochsenbein 牙周骨凿
#6 号柄 **CO26**
#524 号柄 **CO2**



Och-3 Ochsenbein 牙周骨凿
#6 号柄 **CO36**



Och-4 Ochsenbein 牙周骨凿
#6 号柄 **CO46**



Fedi 骨凿

用于软组织修整或去除。清除牙周存留的纤维组织。



1 Fedi 牙周骨凿
#6 号柄 **CPF16**



2 Fedi 牙周骨凿
#6 号柄 **CPF26**



3 Fedi 牙周骨凿
#6 号柄 **CPF36**



4 Fedi 牙周骨凿
#6 号柄 **CPF46**
#24 号柄 **CPF4**



3/4 Solt 牙周骨凿
#6 号柄 **CSOLT3/46**



TG 牙周骨凿
#6 号柄 **CTG6**
#2 号柄 **CTG**

改良版 TG 牙周骨凿
#6 号柄 **CTG-06**
#2 号柄 **CTG-O**



Urban 牙周骨凿
#6 号柄 **CURBAN1**



Urban 骨凿
#6 号柄 **CURBAN2**



S13K/TG Jovanovic 骨刮器 4 mm
#6 号柄 **PJO/16**
#10 号柄 **PJO/1**



S13K/TG Jovanovic 骨刮器 5 mm
#6 号柄 **PJO/26**
#10 号柄 **PJO/2**



Jovanovic Mini 骨刮器
2 mm
#6 号柄 **PJO/2M6**



S13K/TG Jovanovic 骨刮器
6 mm
#6 号柄 **PJO/36**
#10 号柄 **PJO/3**



Jovanovic Mini 骨刮器
3 mm
#6 号柄 **PJO/3M6**



PJO/1 & PJO/2 结合 13KL 骨刮器 4 mm/5 mm
黑金系列 **PPBUSER12X**
#10 号柄 **PPBUSER1/2**



PJO/1 & PJO/3 结合 13KL 骨刮器 4 mm/6 mm
黑金系列 **PPBUSER13X**
#6 号柄 **PPBUSE1/36**
#10 号柄 **PPBUSER1/3**



PJO/2 & PJO/3 结合 13KL 骨刮器 5 mm/6 mm
黑金系列 **PPBUSER23X**
#6 号柄 **PPBUSE2/36**
#10 号柄 **PPBUSER2/3**

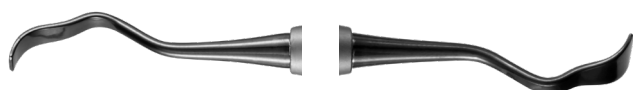

13K/13KL 牙周骨凿 3.2 mm/4.9 mm
黑金系列 **S13K/13KLX**
#9 号柄 **S13K/13KL9**
#6 号柄 **S13K/13KL6**
#2 号柄 **S13K/13KL**



13K/TG 牙周骨凿/骨刮 3.3 mm/3.2 mm
黑金系列 **S13K/TGX**
#9 号柄 **S13K/TG9**
#6 号柄 **S13K/TG6**
#6 号短柄 **S13K/TGS6**
#2 号柄 **S13K/TG**



Back Action 牙周骨凿
黑金系列 **SPAL13KX**
#6 号柄 **SPAL13K6**
#6 号短柄 **SPAL13KS6**



骨凿, 单斜面

主要用于分牙

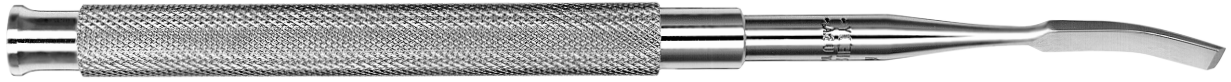

1 Chandler 骨凿

5 mm

CC1



2 Chandler 骨凿

5 mm

CC2



4 Chandler 骨凿

5 mm

CC4



1 Gardner 骨凿

3 mm

CG1



2 Gardner 骨凿

4 mm

CG2



5 Gardner 骨凿

4.3 mm

CG5



6 Gardner 骨凿

4 mm

CG6

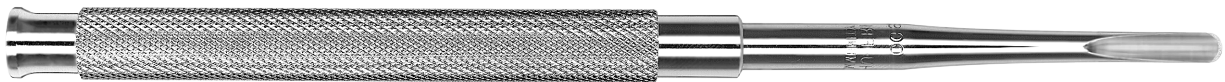

9 Gardner 骨凿

4 mm

CG9

骨凿, 双斜面



7 Chandler 骨凿

4.7 mm

CC7



8 Chandler 骨凿

6.1 mm

CC8



9 Chandler 骨凿

7.1 mm

CC9



3 K-N 骨凿

7.5 mm

CKN3



55 K-N 骨凿

5.5 mm

CKN55



75 K-N 骨凿

7.5 mm

CKN75



18 McFarland Bi-Bevel 外科刮匙
4.2 mm **CM18**



1W Wakefield Bi-Bevel 骨凿
2.7 mm **CW1**



2W Wakefield Bi-Bevel 骨凿
3 mm **CW2**

骨凿, 半圆



13 Chandler 骨凿
3.3 mm **CC13**



15 Chandler 骨凿
6 mm **CC15**

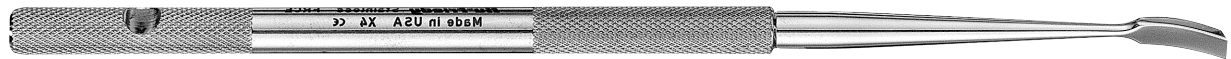

Freer 骨凿
FRCE



Buser 骨凿
6 mm **CBFL112**

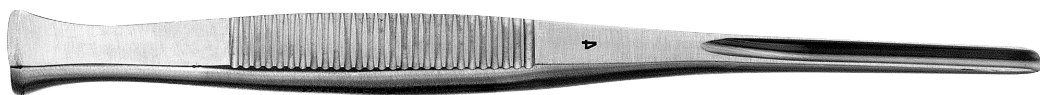

Buser 骨凿
4 mm **CBFL214**



Tabanella 骨凿 1
#6 号柄 **TABANELLA3**



Tabanella 骨凿 2
#6 号柄 **TABANELLA4**

外科刮匙



84 Lucas 外科刮匙

黑金系列	CL84X
#6 号柄	CL846
#522 号柄	CL84



85 Lucas 外科刮匙

黑金系列	CL85X
#6 号柄	CL856
#522 号柄	CL85



86 Lucas 外科刮匙

黑金系列	CL86X
#6 号柄	CL866
#522 号柄	CL86



87 Lucas 外科刮匙

黑金系列	CL87X
#6 号柄	CL876
#522 号柄	CL87

88 Lucas 外科刮匙

黑金系列	CL88X
#6 号柄	CL886
#522 号柄	CL88



2.9 mm

10 Miller 外科刮匙

#6 号柄

CM106

#522 号柄

CM10



3.6 mm

11 Miller 外科刮匙

#6 号柄

CM116

#522 号柄

CM11

4.2 mm

12 Miller 外科刮匙

#6 号柄

CM126

#6 号短柄

CM12S6

#522 号柄

CM12



3.5 mm

2 Molt 外科刮匙

#6 号柄

CM26

#502 号柄

CM2



7.0 mm

2/4 Molt 外科刮匙

黑金系列

CM2/4X

#6 号短柄

CM2/4S6

#522 号柄

CM2/4

3.5 mm



7.0 mm

4 Molt 外科刮匙

#6 号柄

CM46

#502 号柄

CM4



6.3 mm

4 Molt 外科改良刮匙, 左侧

#510 号柄

CM4L



4 Molt 外科改良刮匙, 右侧
#510 号柄 **CM4R**



5L Molt 外科刮匙
#502 号柄 **CM5L**



6R Molt 外科刮匙
#502 号柄 **CM6R**



8 Miller 外科刮匙
#6 号柄 **CM86**
#522 号柄 **CM8**

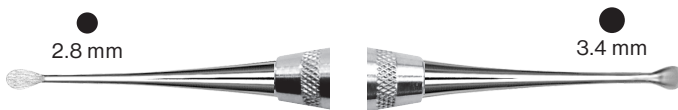

9 Miller 外科刮匙
#6 号柄 **CM96**
#522 号柄 **CM9**

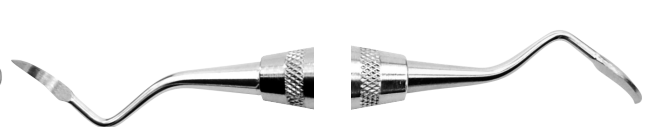

1 Hoexter 外科刮匙
#6 号柄 **HOEXTER1**

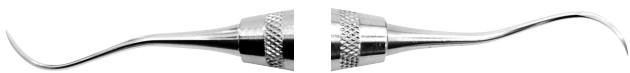

2 Hoexter 外科刮匙
#6 号柄 **HOEXTER2**

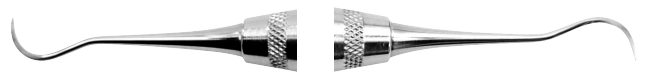

3 Hoexter 外科刮匙
#6 号柄 **HOEXTER3**



Perio 外科刮匙



PM Prodigy 外科刮匙
黑金系列, 短柄 **PMPRODIGYS**



8K/9K Kirkland 外科刮匙
#6 号柄 **SK8/96**
#2 号柄 **SK8/9**



3/4 Kramer-Nevins 外科刮匙
#6 号柄 **SKN3/46**



4 Kramer-Nevins 外科刮匙
#6 号柄 **SKN46**



KRA-1 Kramer 外科刮匙
#6 号柄 **SKRA16**



KRA-2 Kramer 外科刮匙
#6 号柄 **SKRA26**



KRA-3 Kramer 外科刮匙
#9 号柄 **SKRA39**
#6 号柄 **SKRA36**



PR1/2 Prichard 外科刮匙	
#9 号柄	SPR1/29
#6 号柄	SPR1/26
#6 号短柄	SPR1/2S6
#2 号柄	SPR1/2
#2 号短柄	SPR1/2S



11/12 Sugarman 外科刮匙	
#6 号柄	SS11/126
#2 号柄	SS11/12



5S/6S Sugarman 外科刮匙	
#6 号柄	SS5/66
#2 号柄	SS5/6



9S/10S Sugarman 外科刮匙	
#6 号柄	SS9/106
#2 号柄	SS9/10

牙挺

Apexo 牙挺 用于位置较深的牙根

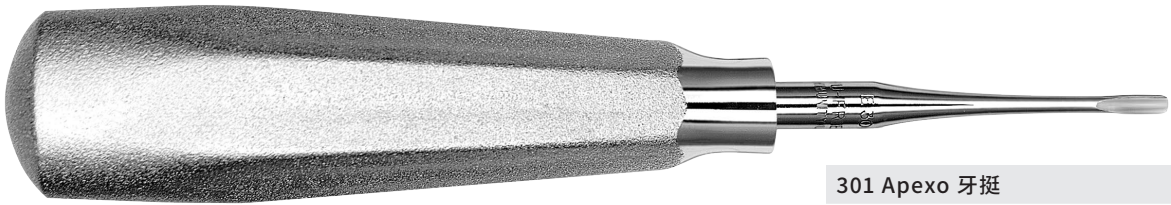

301 Apexo 牙挺	
标准	E301
有锯齿	E301SERR
小号手柄	E301SM



302 Apexo 牙挺
E302



303 Apexo 牙挺
E303



4 Schmeckeber Apex 牙挺
E4



5 Schmeckeber Apex 牙挺
E5

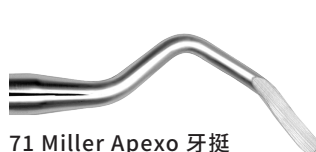

71 Miller Apex 牙挺
E71

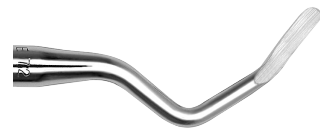

72 Miller Apex 牙挺
E72



73 Miller Apex 牙挺
E73



74 Miller Apex 牙挺
E74



Seldin 系列牙挺

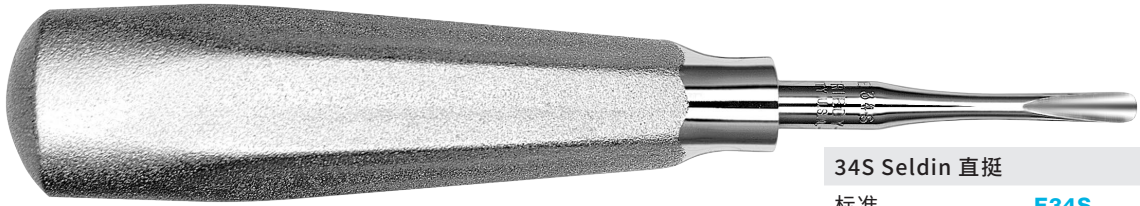

34S Seldin 直挺

标准	E34S
小号手柄	E34SSM
有锯齿	E34SSERR



1L Seldin 三角挺
上下颌磨牙牙根
E1L



1R Seldin 三角挺
上下颌磨牙牙根
E1R



2 Seldin 牙挺
下颌第三磨牙
E2S



301W Seldin 牙挺
位置较深的牙根
E301W



304W Seldin 牙挺
位置较深的牙根
E304W



34 Seldin 直挺
上下颌前牙牙根
E34



3 Seldin 牙挺
上下颌前牙牙根
E3S



4L Seldin 牙挺
小号 E1L, 上下颌磨牙牙根
E4L



4R Seldin 牙挺
小号 E1R, 上下颌磨牙牙根
E4R

Winter 十字交叉手柄牙挺

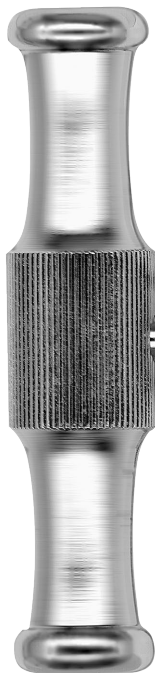

1R Cross-Bar 三角挺
E1RX



11L 丁字挺
E11LX



1L Cross-Bar 三角挺
E1LX

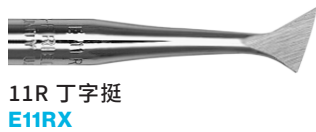

11R 丁字挺
E11RX



12L Cross-Bar 牙挺
E12LX



12R Cross-Bar 牙挺
E12RX



14L Cross-Bar 牙挺
E14LX



14R Cross-Bar 牙挺
E14RX



Heidbrink 牙挺

用于上下颌前牙以及牙根



1 Heidbrink 直挺
E1



2 Heidbrink 直挺
E2



40 Heidbrink 直挺
E40



41 Heidbrink 直挺
E41

Coupland Gouge 牙挺



1C Coupland (Gouge) 牙挺
E1C



2C Coupland (Gouge) 牙挺
E2C



3C Coupland (Gouge) 牙挺
E3C

Coupland Gouge 牙挺-英式



A1C Coupland 牙挺
EA1C



A2C Coupland 牙挺
EA2C



#A3C Coupland 牙挺
EA3C

Cryer 牙挺

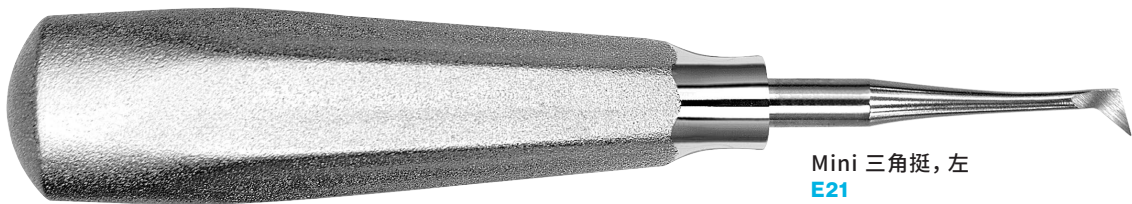

Mini 三角挺, 左
E21



Mini 三角挺, 右
E22



25 三角挺
中号
E25



26 三角挺
中号
E26



31 三角挺
大号
E31



32 三角挺
大号
E32



44 三角挺
小号
E44



45 三角挺
小号
E45



A30 三角挺
EA30



A31 三角挺
EA31



T形手柄牙挺

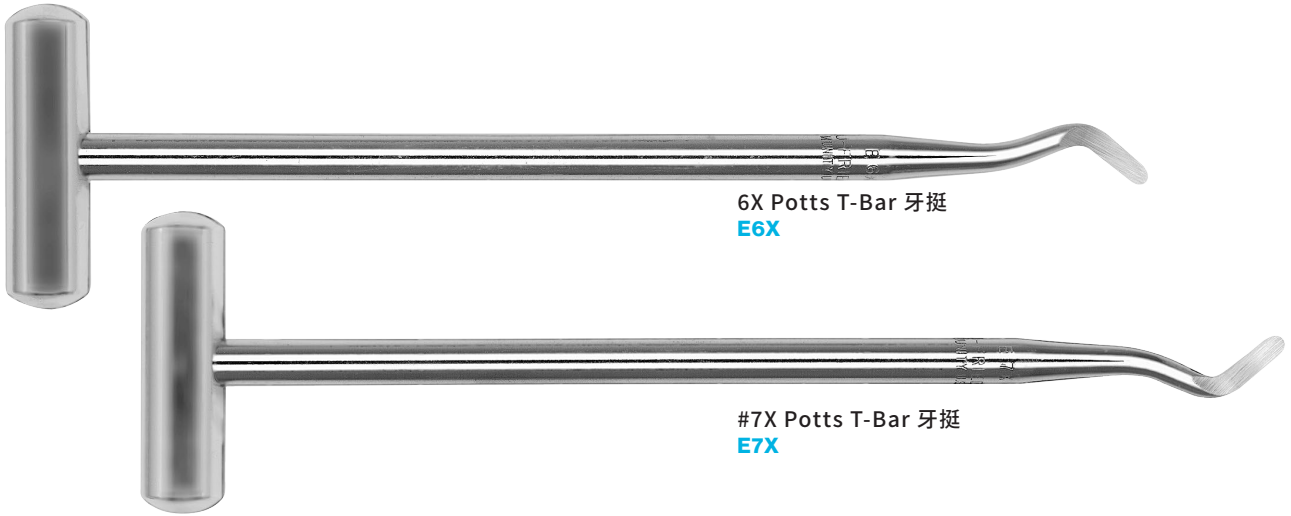

其它牙挺



11 Stout 牙挺
E11



11A Stout 牙挺
E11A



11H Hourigan 牙挺
E11H



11M MacMillan 牙挺
E11M



12 牙挺
E12



12M MacMillan 牙挺
E12M



13M MacMillan 牙挺
E13M



15 Woodward 牙挺
E15



16 Woodward 牙挺
E16



19 Root 牙挺
E19



190 牙挺
E190



191 牙挺
E191

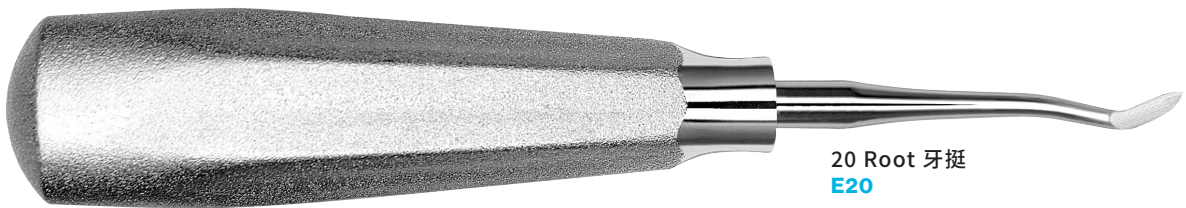

23 牙挺
E23



31 Friedman (Craig) 牙挺
上下颌尖牙
E31F



32 Friedman (Craig) 牙挺
上下颌尖牙
E32F

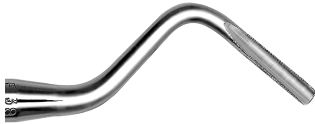

38 牙挺, 有锯齿
残根
E38



39 牙挺, 有锯齿
残根
E39



44C Bradley 牙挺
第三磨牙及根
E44C



46 牙挺
上颌后牙牙根
E46



46R 牙挺
上颌后牙牙根
E46R



51 Curtis 牙挺
E51



52 Curtis 牙挺
E52



6 Potts 牙挺
E6



7 Potts 牙挺
E7



E63 牙挺
E63



77 牙挺, 有锯齿
E77



8 Crane Pick 牙挺
E8

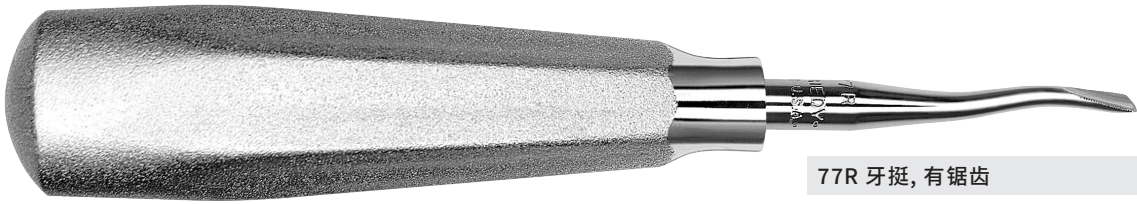

77R 牙挺, 有锯齿

标准 **E77R**

小号手柄 **E77RSM**



80 牙挺
E80



81 牙挺
上颌前牙牙根及较小牙
E81



81A 牙挺
前牙牙根
E81A



81E 牙挺
前牙牙根
E81E



92 牙挺, 有锯齿
E92



98 牙挺
E98



93 牙挺, 有锯齿
E93

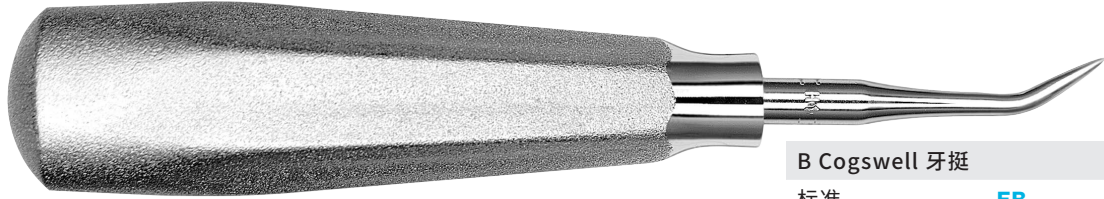

B Cogswell 牙挺	
标准	EB
小号手柄	EBSM



A Cogswell 牙挺
EA



Warwick-James 牙挺-右侧
#504 号柄
EWJR



Warwick-James 牙挺-直
#504 号柄
EWJS



Warwick-James 牙挺-左侧
#504 号柄
EWJL



5 Hourigan 牙挺
EH5



6 Hourigan 牙挺
EH6

Hoexter 牙挺



Hoexter 远中微创牙挺, 左侧
3 mm
EDLL3



Hoexter 近中微创牙挺, 左侧
3 mm
EMLL3



Hoexter 近中微创牙挺, 右侧
3 mm
EMLR3



Hoexter 远中微创牙挺, 右侧
3 mm
EDLR3



Hoexter 远中微创牙挺, 左侧
5 mm
EDLL5

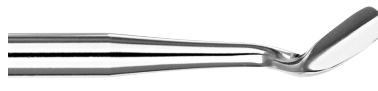

Hoexter 远中微创牙挺, 右侧
5 mm
EDLR5

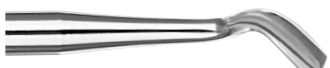

Hoexter 近中微创牙挺, 左侧
5 mm
EMLL5



Hoexter 近中微创牙挺, 右侧
5 mm
EMLR5

Luxating 微创牙挺



Luxating 微创牙挺, 2 mm 弯头

黑金系列 **EL2CX**

标准 **EL2C**



Luxating 微创牙挺, 2 mm 直头

黑金系列 **EL2SX**

标准 **EL2S**



Luxating 微创牙挺, 3 mm 弯头

黑金系列 **EL3CX**

标准 **EL3C**



Luxating 微创牙挺, 3 mm 直头

黑金系列 **EL3SX**

标准 **EL3S**



Luxating 微创牙挺, 4 mm 弯头

黑金系列 **EL4CX**

标准 **EL4C**



Luxating 微创牙挺, 4 mm 直头

黑金系列 **EL4SX**

标准 **EL4S**



Luxating 微创牙挺, 5 mm 弯头

黑金系列 **EL5CX**

标准 **EL5C**



Luxating 微创牙挺, 5 mm 直头

黑金系列 **EL5SX**

标准 **EL5S**



Slim 超薄微创牙挺



Slim 超薄微创牙挺 2 mm, 长杆 弯头

黑金系列 [ELSLIM2CLX](#)

标准 [ELSLIM2CL](#)



Slim 超薄微创牙挺 2 mm, 短杆 弯头

黑金系列 [ELSLIM2CSX](#)

标准 [ELSLIM2CS](#)



Slim 超薄微创牙挺 2 mm, 长杆 直头

黑金系列 [ELSLIM2SLX](#)

标准 [ELSLIM2SL](#)



Slim 超薄微创牙挺 2 mm, 短杆 直头

黑金系列 [ELSLIM2SSX](#)

标准 [ELSLIM2SS](#)



Slim 超薄微创牙挺 3 mm, 长杆 弯头

黑金系列 [ELSLIM3CLX](#)

标准 [ELSLIM3CL](#)



Slim 超薄微创牙挺 3 mm, 短杆 弯头

黑金系列 [ELSLIM3CSX](#)

标准 [ELSLIM3CS](#)



Slim 超薄微创牙挺 3 mm, 长杆 直头

黑金系列 [ELSLIM3SLX](#)

标准 [ELSLIM3SL](#)



Slim 超薄微创牙挺 3 mm, 短杆 直头

黑金系列 [ELSLIMSSX](#)

标准 [ELSLIM3SS](#)

Luxating Hybrid 牙挺



Luxating Hybrid 牙挺, 远中大号

黑金系列 **EPTLGD**

#6 号柄 **EPTLGD**



Luxating Hybrid 牙挺, 近中大号

黑金系列 **EPTLGM**

#6 号柄 **EPTLGM**



Luxating Hybrid 牙挺, 小号弯头

黑金系列 **EPTSMCX**

#6 号柄 **EPTSMC**



Luxating Hybrid 牙挺, 远中小号

黑金系列 **EPTSMDX**

#6 号柄 **EPTSMD**



Luxating Hybrid 牙挺, 近中小号

黑金系列 **EPTSMX**

#6 号柄 **EPTSM**



Luxating Hybrid 牙挺, 小号直头

黑金系列 **EPTSMSX**

#6 号柄 **EPTSMS**



Luxating Hybrid 牙挺, 直菱形

黑金系列 **EPTSSPX**

#6 号柄 **EPTSSP**

Syndesmotomes 微创根挺



11 Bernard 根挺/分离牙龈, 直

黑金系列 **BER11X**

#504 号柄 **BER11**



6 Bernard 根挺/分离牙龈, 右

黑金系列 **BER6X**

#504 号柄 **BER6**



7 Bernard 根挺/分离牙龈, 左

黑金系列 **BER7X**

#504 号柄 **BER7**



骨锉

平纹骨锉



12 Howard 骨锉

#6 号柄 **BF126**

#522 号柄 **BF12**



1W Wahl 骨锉

#6 号柄 **BF1W6**

#522 号柄 **BF1W**



2W Wahl 骨锉

#6 号柄 **BF2W6**

#522 号柄 **BF2W**



21 Miller 骨锉

#6 号柄 **BF216**

#522 号柄 **BF21**



45 Miller 骨锉
 #6 号柄 **BF456**
 #522 号柄 **BF45**



52 Miller 骨锉
 #6 号柄 **BF526**
 #522 号柄 **BF52**



64 Miller 骨锉
 #6 号柄 **BF646**
 #522 号柄 **BF64**



67 Howard 骨锉
 #6 号柄 **BF676**
 #522 号柄 **BF67**

十字交叉纹骨锉



1X Miller-Colburn 骨锉
 #6 号柄 **BF1X6**
 #522 号柄 **BF1X**



2X Miller-Colburn 骨锉
 #6 号柄 **BF2X6**
 #522 号柄 **BF2X**



3X Miller-Colburn Bone 骨锉
 #6 号柄 **BF3X6**
 #522 号柄 **BF3X**

牙周锉



11/12 Buck 牙周锉

#6 号柄	FB11/126
#522 号柄	FB11/12



1S/2S Sugarman 牙周锉, 近中/远中

#6 号柄	FS1/2S6
#2 号柄	FS1/2S



3S/4S Sugarman 牙周锉, 颊侧/舌侧

#6 号柄	FS3/4S6
#2 号柄	FS3/4S



#9/10 Schluger 牙周锉, 弯头

#6 号柄	FS9/10S6
#522 号柄	FS9/10S

拔牙钳

Atlas 拔牙钳



150 Atlas 拔牙钳
上颌通用
F150IS



151 Atlas 拔牙钳
下颌通用
F151IS



1 Atlas 拔牙钳
上颌前牙
F1IS



222 Atlas 拔牙钳
下颌磨牙
F222IS



23 Atlas 拔牙钳
牛角式
F23IS



53L Atlas 拔牙钳
上颌磨牙
F53LIS



53R Atlas 拔牙钳
上颌右侧磨牙
F53RIS



69 Tomes Atlas 拔牙钳
上颌/下颌根钳
F69IS



88L Nevius Atlas 拔牙钳
上颌左侧磨牙
F88LIS



88R Nevius Atlas 拔牙钳
上颌右侧磨牙
F88RIS



150 Atlas 拔牙钳
上颌通用, 根尖钳
FAF150IS



151 Atlas 拔牙钳
下颌通用, 根尖钳
FAF151IS



1 Atlas 拔牙钳
上颌前牙, 根尖钳
FAF1IS



222 Atlas 拔牙钳
下颌磨牙, 根尖钳
FAF222IS

Apical 拔牙钳



Apical 拔牙钳 1
上颌前牙
FAF1



Apical 拔牙钳 150
上颌通用
FAF150



Apical 拔牙钳 151
下颌通用
FAF151



Apical 拔牙钳 222
下颌磨牙
FAF222



Apical 拔牙钳 X67A
上颌磨牙
FAFX67A



Apical 拔牙钳 X74N
下颌前牙
FAFX74N



Atraumair 拔牙钳



13 Atraumair 拔牙钳
下颌前磨牙
F13XS



1 Atraumair 标准 拔牙钳
上颌前牙
F1XS



23 Atraumair 拔牙钳
牛角式, 下颌磨牙
F23XS

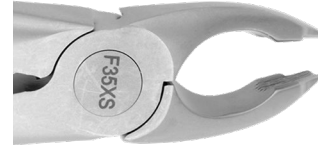

35 Atraumair 拔牙钳
上颌前磨牙/尖牙
F35XS



36 Atraumair 拔牙钳
上颌前牙
F36XS



67 Atraumair 拔牙钳
上颌磨牙
F67XS



1 Atraumair Apical 拔牙钳
上颌前牙
FAF1XS



35 Atraumair Apical 拔牙钳
上颌前磨牙/尖牙
FAF35XS



36 Atraumair Apical 拔牙钳
下颌前磨牙/前牙
FAF36XS



45 Atraumair 拔牙钳, 有锯齿
下颌牙根
FX45XS



51 Atraumair 拔牙钳, 有锯齿
上颌牙根
FX51XS



73 Atraumair 拔牙钳
下颌磨牙
FX73XS



79 Atraumair 拔牙钳
下颌磨牙
FX79XS



下颌前牙和前磨牙拔牙钳



151A Cryer 拔牙钳
下颌前牙, 前磨牙和根通用
F151A



151AS Split Beak 拔牙钳, 有锯齿
下颌前牙, 前磨牙和根通用
F151AS



203 拔牙钳
下颌前牙, 前磨牙和根通用
F203



MD-3 Mead拔牙钳,
有锯齿
下颌切牙和根
FMD3



13 欧式拔牙钳
下颌前磨牙
标准 **FX13E**
有锯齿 **FX13**

下颌磨牙拔牙钳



16 拔牙钳
下颌第一和第二磨牙
直柄 **F16M**
标准 **F16**



17 拔牙钳
下颌第一和第二磨牙
F17



217 Hu-Friedy 拔牙钳
下颌第一和第二磨牙
F217



222 拔牙钳
下颌第三磨牙
F222

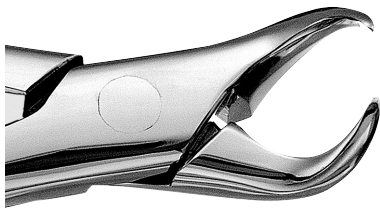

23 拔牙钳
下颌第一和第二磨牙
F23



3FS Woodward 拔牙钳
下颌磨牙
F3FS



MD-4 Mead 拔牙钳, 有锯齿
下颌第一, 第二磨牙&第三磨牙
FMD4



22 欧式拔牙钳
下颌磨牙
标准 **FX22**
哑光面 **FX22E**



73 欧式拔牙钳, 有锯齿
下颌磨牙
FX73



79 欧式拔牙钳, 有锯齿
下颌第三磨牙
标准 **FX79**
哑光面 **FX79E**

下颌通用拔牙钳



#151 Cryer 拔牙钳
下颌前牙, 前磨牙和根 通用
F151



上颌磨牙拔牙钳



10S 拔牙钳
上颌磨牙
F10S



18L Harris 拔牙钳
上颌第一&第二磨牙, 左侧
F18L



18R Harris 拔牙钳
上颌第一&第二磨牙, 右侧
F18R



210H 拔牙钳
上颌第三磨牙
F210H



210S 拔牙钳
上颌第三磨牙
F210S



53L 拔牙钳
上颌第一&第二磨牙, 左侧
F53L



53R 拔牙钳
上颌第一和第二磨牙, 右侧
F53R



88L Nevius 拔牙钳
上颌第一和第二磨牙, 左侧
F88L



88R Nevius 拔牙钳
上颌第一和第二磨牙, 右侧
F88R



89 Cook 拔牙钳
上颌磨牙, 右侧
F89



90 Cook 拔牙钳
上颌磨牙, 左侧
F90



MD-2 Mead 拔牙钳, 有锯齿
上颌第一, 第二磨牙和第三磨牙通用
FMD2



17 欧式拔牙钳
上颌磨牙, 右侧
标准 FX17
哑光面 FX17E



18 欧式拔牙钳, 有锯齿
上颌磨牙, 左侧
标准 FX18
哑光面 FX18E



67A 欧式拔牙钳, 有锯齿
上颌第三磨牙
FX67A



上下颌前牙拔牙钳



101 Hull 拔牙钳
上下颌前磨牙和乳牙通用
F101



62 拔牙钳
上下颌切牙, 尖牙, 前磨牙和乳牙通用
F62

上颌前牙和前磨牙拔牙钳



1 标准拔牙钳
上颌切牙和尖牙
F1



150 Cryer 拔牙钳
上颌切牙, 尖牙, 前磨牙和根通用
F150



150A Cryer 拔牙钳
上颌切牙, 尖牙, 前磨牙通用
F150A



150AS Split Beak 拔牙钳, 有锯齿
上颌切牙, 尖牙, 前磨牙通用
F150AS



1A Henanhan 拔牙钳
F1A



286 拔牙钳
上颌根, 切牙和前磨牙
F286



32 Parmly Alveolar 拔牙钳
上颌尖牙, 前磨牙&磨牙
F32



32A Parmly 拔牙钳
F32A



99C Kells 拔牙钳
上颌切牙, 尖牙和前磨牙
F99C



MD-1 Mead 拔牙钳, 有锯齿
上颌切牙, 尖牙, 前磨牙&根
FMD1



1 欧式拔牙钳
上颌前牙
标准 **FX1**
哑光面 **FX1E**



35 欧式拔牙钳
上颌切牙, 尖牙, 前磨牙和根
哑光面 **FX35E**



7 欧式拔牙钳
上颌前磨牙
标准 **FX7**
哑光面 **FX7E**

Pedo 欧式儿童拔牙钳



1C Pedo 欧式儿童拔牙钳
下颌切牙
哑光面 **FX1CE**



2C Pedo 欧式儿童拔牙钳
下颌乳磨牙
哑光面 **FX2CE**



3C Pedo 欧式儿童拔牙钳
下颌牙根
哑光面 **FX3CE**



4C Pedo 欧式儿童拔牙钳
上颌乳牙
哑光面 **FX4CE**



5C Pedo 欧式儿童拔牙钳
上颌切牙&尖牙
哑光面 **FX5CE**



6C Pedo 欧式儿童拔牙钳
上颌磨牙
哑光面 **FX6CE**



7C Pedo 欧式儿童拔牙钳
上颌牙根
哑光面 **FX7CE**

Pedo 儿童拔牙钳



150K 小号 Pedo 儿童拔牙钳
上颌乳切牙和根
F150K



151K 小号 Pedo 儿童拔牙钳
下颌乳切牙和根
F151K



23K 牛角式小号 Pedo 儿童拔牙钳
下颌乳磨牙
F23K



Presidential™ Pedo拔牙钳



150S Presidential™ Pedo 儿童拔牙钳
上颌乳牙和根通用
F150S



151S Presidential™ Pedo 儿童拔牙钳
下颌乳牙和根通用
F151S

Presidential™ Pedo 彩虹系列儿童拔牙钳

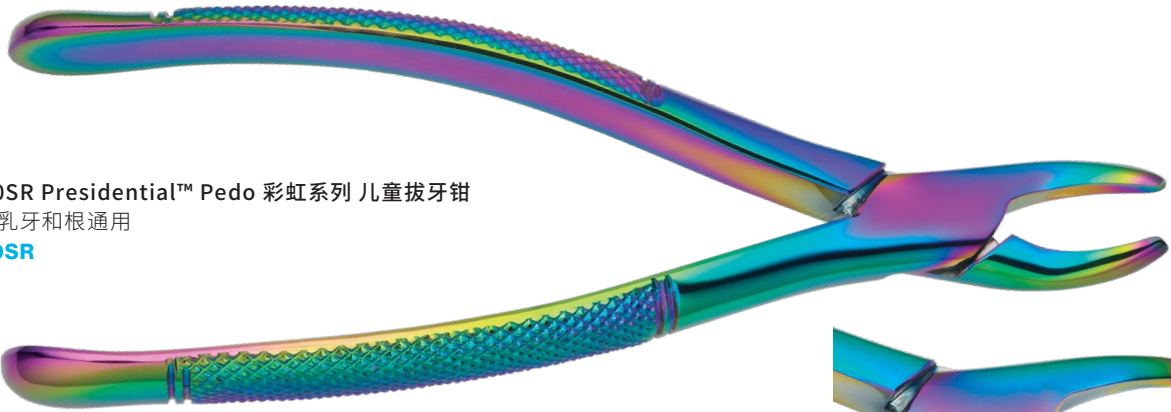

F150SR Presidential™ Pedo 彩虹系列 儿童拔牙钳
上颌乳牙和根通用
F150SR



F151SR Presidential™
Pedo 彩虹系列儿童拔牙钳
下颌乳牙&根通用
F151SR

标准 Pedo 儿童拔牙钳



150XAS Split Beak Pedo 儿童拔牙钳,
有锯齿
上颌乳牙, 通用
F150XAS



151XAS Split Beak Pedo 儿童拔牙钳,
有锯齿
下颌乳牙, 通用
F151XAS



16S Pedo 儿童拔牙钳
下颌磨牙
F16S

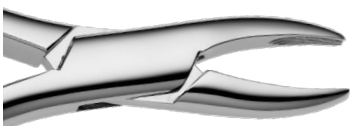

1S Pedo 儿童拔牙钳
上颌切牙和尖牙
F1S

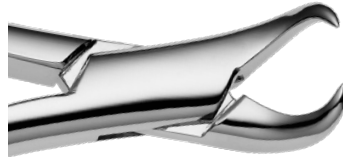

23S牛角式 Pedo 儿童 拔牙钳
下颌第一和第二磨牙
F23S

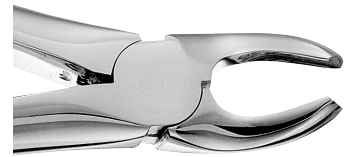

39 Pedo 儿童拔牙钳
下颌第一&第二磨牙
F39



40 Pedo 儿童拔牙钳
下颌磨牙
F40

根钳



300 根钳, 有锯齿
上颌牙根
F300



301 根钳, 有锯齿
下颌牙根
F301



65 根钳
上颌牙根, 残根和滞留/多生牙
F65



69 根钳
上下颌残根和牙根
F69



233 根钳, 有锯齿
下颌牙根
FX233



33 欧式根钳, 有锯齿
下颌牙根
FX33

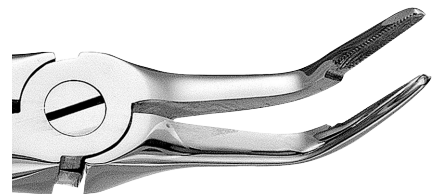

46L 根钳, 有锯齿
下颌牙根
标准 **FX46L**
哑光面 **FX46LE**



49 根钳, 有锯齿
上颌牙根
标准 **FX49**
哑光面 **FX49E**



51 欧式根钳, 有锯齿
上颌牙根
标准 **FX51**
哑光面 **FX51E**



74 欧式根钳, 有锯齿
下颌牙根
FX74



74N 欧式根钳, 有锯齿
下颌牙根
FX74N



76S 上颌根钳, 有锯齿
FX76S



97 根钳, 有锯齿
上颌牙根
标准 **FX97**
哑光面 **FX97E**



233 根钳, 有锯齿
下颌牙根
标准 **FX233**
哑光面 **FX233E**

种植骨再生器械



Allen 膜测量卡
ALLEN CARD



金属混合杯
MCUPE

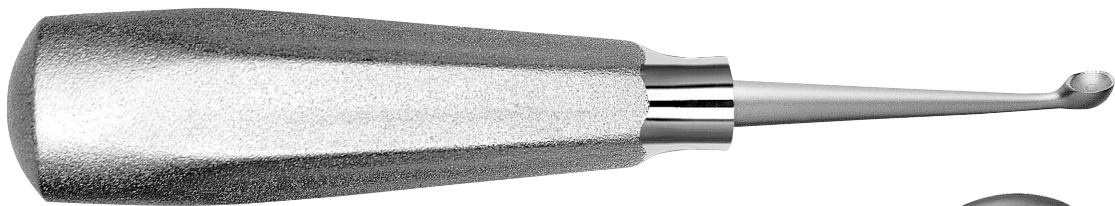

Dr. Jovanovic 骨挖器
5 mm
BSJ05



固定植骨夹持钳
19 cm
CBBC



Labanca 骨刮
7 mm

#6 号柄 **CSLABANCA6**



Palti 骨粉勺

黑金系列 **IMP6522X**

#6 号柄 **IMP65226**

#10 号柄 **IMP6522**



Palti 上颌窦提升器械, 小号

#6 号柄 **IMP6523S6**

#10 号柄 **IMP6523S**



Palti 上颌窦提升器械

#6 号柄 **IMP6524S6**

#10 号柄 **IMP6524S**

生物膜放置器



生物膜放置器

黑金系列 **PMP1X**

#6 号柄 **PMP16**

#6 号短柄 **PMP1S6**

#2 号柄 **PMP1**

#2 号短柄 **PMP1S**



Euwe 生物膜放置器

#6 号柄 **PMP1E**



改良PMP1生物膜放置器

#6 号柄 **PMP7002**



Chu 放置器

PPIS



充填/挤压器械



Grisdale 骨粉充填器

- 黑金系列 **PLGGR1X**
- #6 号柄 **PLGGR1**
- #6 号短柄 **PLGGR1S6**



Jovanovic 骨粉充填器

- 黑金系列 **PLGJO/4X**
- #6 号柄 **PLGJO/46**
- #522 号柄 **PLGJO/4**



Jovanovic 骨粉充填/骨膜分离器

- #6 号柄 **PLGJO/56**



Labanca 骨粉充填器

- 黑金系列 **PLGLABANCX**
- #6 号柄 **PLGLABANC6**

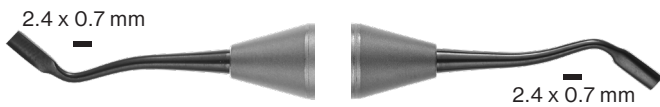

Rompen 骨粉充填器, 颊/舌

- 黑金系列 **PLGROMP1X**

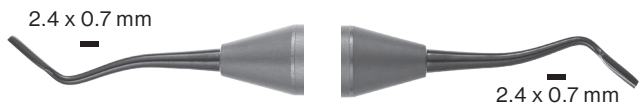

Rompen 骨粉充填器, 近中/远中

- 黑金系列 **PLGROMP2X**



Tahmaseb 上颌窦提升/骨粉充填

- #6 号柄 **PLGTAHM**



Euwe 骨粉勺/充填器

- #6 号短柄 **CSEUWES6**

止血钳



#1 Kelly 止血钳, 直
13 cm H1

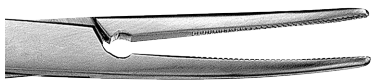

#2 Kelly 止血钳, 弯
13 cm H2



#3 Mosquito 止血钳, 弯
10 cm H3



#4 Mosquito 止血钳, 直
10 cm H4



#5 1x2 止血钳, 直
13 cm H5

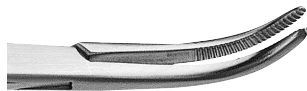

Adson 止血钳, 弯
19 cm HAC

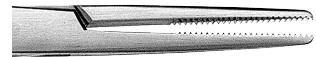

Adson 止血钳, 直
19 cm HAS



Hartmann 止血钳, 弯
10 cm **HHC**



Hartmann 止血钳, 直
10 cm **HHS**



Kocher 止血钳, 弯
14 cm **HKC**



Kelly-Rankin 止血钳, 弯
16 cm **HKRC**



Kelly-Rankin 止血钳, 直
HKRS

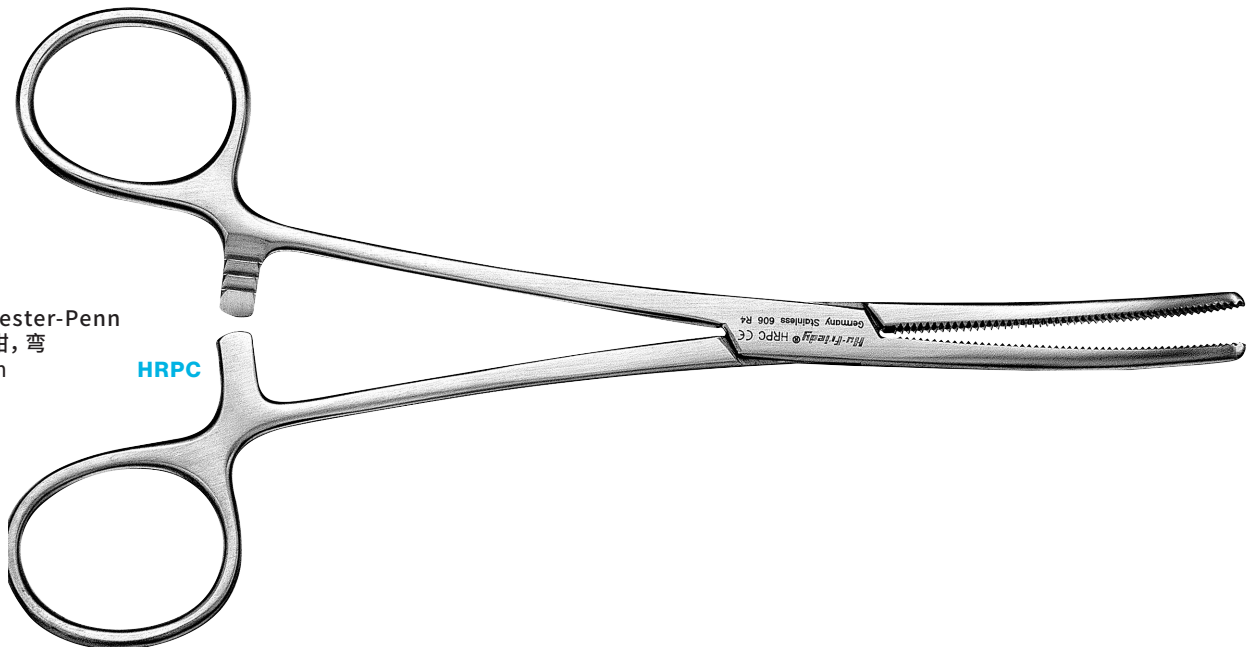

Rochester-Penn
止血钳, 弯
15 cm **HRPC**

种植器械



Tabanella 微创挺

TABANELLA2

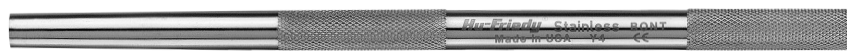

上颌窦开窗器

7 mm

BONT



双头骨粉挤压器

6-8 mm

BPACK



骨锉

1.5 mm

RASP



Tabanella 邻间隙骨粉充填器

TABANELLA1



上颌窦提升器



300 上颌窦外提升器

黑金	IMP300X
#6 号柄	IMP3006
#6 号短柄	IMP300S6



Simion 上颌窦外提升器

#6 号柄	IMP300SIM
-------	------------------



725 上颌窦外提升器

#6 号柄	IMP6343S6
#522 号柄	IMP6343S



709 上颌窦外提升器

#6 号柄	IMP6344S6
#522 号柄	IMP6344S



上颌窦外提升器
3 mm

#6 号柄	IMP63456
#6 号短柄	IMP6345S6
#522 号柄	IMP6345S
#10 号柄	IMP6345-71

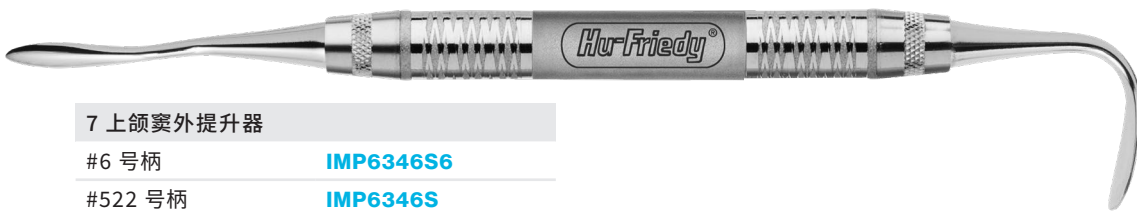

7 上颌窦外提升器

#6 号柄	IMP6346S6
#522 号柄	IMP6346S



914 上颌窦外提升器

#6 号柄	IMP6347S6
#522 号柄	IMP6347S

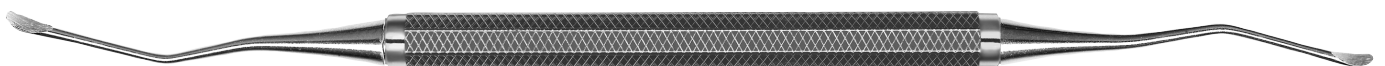

912 上颌窦外提升器

#522 号柄	IMP6348S
---------	-----------------



Palti 上颌窦外提升器

#6 号柄

IMP6524S6



Kramer-Nevins Acute 上颌窦外提升器

黑金系列

IMP6577SCX

#6 号柄

IMP6577SC6

#10 号短柄

IMP6577SC



Kramer-Nevins Obtuse 上颌窦外提升器

黑金系列, 短柄

IMP6578SX

#6 号柄

IMP65786

#2 号柄

IMP6578



上颌窦外提升器

#6 号柄

IMP7044K



Jovanovic 上颌窦外提升器

#6 号柄

IMPJO66

#522 号柄

IMPJO6



1 Rompen 上颌窦外提升器

#6 号柄

IMPROMP16



2 Rompen 上颌窦外提升器

#6 号柄

IMPROMP26



3 Rompen 上颌窦外提升器

#6 号柄

IMPROMP36



1 上颌窦外提升器
3.5 mm

#6 号柄	IMP SIM16
#10 号短柄	IMP SIM1



Tarnow-Eskow 上颌窦外提升器

#6 号柄	IMP STE1/26
-------	--------------------

1 Urban 上颌窦外提升器

#6 号柄	IMP URBAN16
#6 号短柄	IMP URBA1S6



2 Urban 上颌窦外提升器

#6 号柄	IMP URBAN26
#6 号短柄	IMP URBA2S6

3 Urban 上颌窦外提升器

#6 号柄	IMP URBAN36
-------	--------------------



上颌窦外提升器

#6 号柄	PES IM16
#40 号柄	PES IM1



1 上颌窦外提升器

黑金系列	SINC 1X
黑金系列, 短柄	SINC 1SX
#6 号柄	SINC 1
#6 号短柄	SINC 1S6



2 上颌窦外提升器

黑金系列	SINC 2X
黑金系列, 短柄	SINC 2SX
#6 号柄	SINC 2
#6 号短柄	SINC 2S6



Rompen Schneiderian 膜分离器

4.2 mm	SSP R1
--------	---------------



基台器械



1 Zingheim 骨膜分离器

#6 号柄 **IPZ16**

#522 号柄 **IPZ1**



2 Zingheim 种植定位器

#6 号柄 **IPZ26**

#522 号柄 **IPZ2**



3 Zingheim 骨膜分离器

#6 号柄 **IPZ36**

#522 号柄 **IPZ3**

种植用探针



种植刻度探针 (7-10-13-15-18)

#6 号柄 **IMPSIM36**

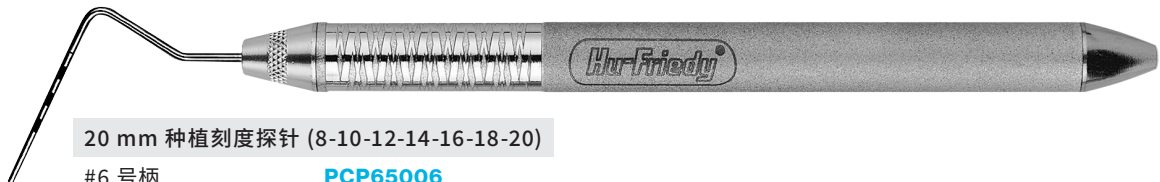

20 mm 种植刻度探针 (8-10-12-14-16-18-20)

#6 号柄 **PCP65006**

#30 号柄 **PCP6500**

骨劈开/挤压器



Osteotome 骨劈开器, 直

7-10-13-15-18 mm

4 mm

OSS6518S



Osteotome 骨劈开器, 弯

7-10-13-15-18 mm

4 mm

OSS6519CS



Osteotome 骨劈开器, 直

7-10-13-15-18 mm

7.5 mm

OSS6520S



Osteotome 骨劈开器, 弯

7-10-13-15-18 mm

7.5 mm

OSS6521CS



Jovanovic Osteotome 骨劈开器
6 mm **OSTJ08**

骨挤压器

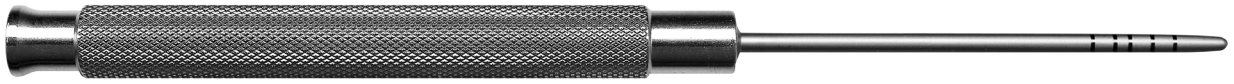

1 Palti Osteotome 骨挤压器
7-10-13-15-18 mm
2.7 mm **OSTPAL1**



2 Palti Osteotome 骨挤压器
7-10-13-15-18 mm
3.2 mm **OSTPAL2**



3 Palti Osteotome 骨挤压器
7-10-13-15-18 mm
3.7 mm **OSTPAL3**



4 Palti Osteotome 骨挤压器
7-10-13-15-18 mm
4.2 mm **OSTPAL4**



可替换 Osteotome 手柄
OSTMGRIF

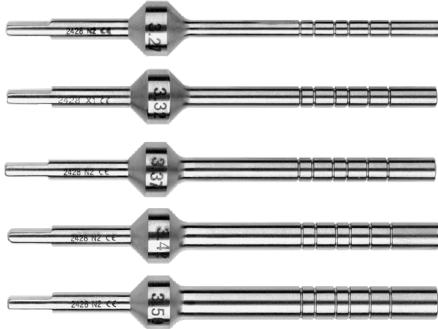

Osteotome 骨挤压器, 直

- 骨挤压器2.7 mm,直,平头 **OSTMPU27**
- 骨挤压器3.2 mm,直,平头 **OSTMPU32**
- 骨挤压器3.7 mm,直,平头 **OSTMPU37**
- 骨挤压器4.2 mm,直,平头 **OSTMPU42**
- 骨挤压器5.0 mm,直,平头 **OSTMPU50**



Osteotome 骨挤压器, 弯

- 骨挤压器2.7 mm,弯,平头 **OSTMPU27A**
- 骨挤压器3.2 mm,弯,平头 **OSTMPU32A**
- 骨挤压器3.7 mm,弯,平头 **OSTMPU37A**
- 骨挤压器4.2 mm,弯,平头 **OSTMPU42A**
- 骨挤压器5.0 mm,弯,平头 **OSTMPU50A**



Osteotome 骨挤压器, 直, 凹头

- 骨挤压器2.7 mm,直,凹头 **OSTMSH27**
- 骨挤压器3.2 mm,直,凹头 **OSTMSH32**
- 骨挤压器3.7 mm,直,凹头 **OSTMSH37**
- 骨挤压器4.2 mm,直,凹头 **OSTMSH42**
- 骨挤压器5.0 mm,直,凹头 **OSTMSH50**



Osteotome 骨挤压器, 弯, 凹头

- 骨挤压器2.7 mm,弯,凹头 **OSTMSH27A**
- 骨挤压器3.2 mm,弯,凹头 **OSTMSH32A**
- 骨挤压器3.7 mm,弯,凹头 **OSTMSH37A**
- 骨挤压器4.2 mm,弯,凹头 **OSTMSH42A**
- 骨挤压器5.0 mm,弯,凹头 **OSTMSH50A**

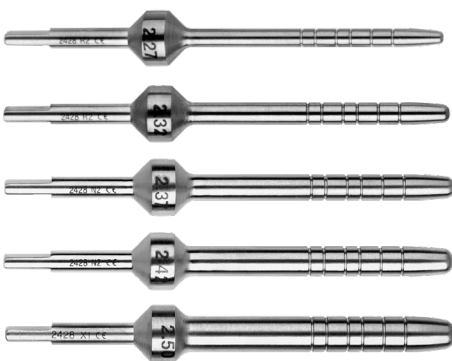

Osteotome 骨挤压器, 直, 尖端微凸

- 骨挤压器2.7 mm,弯,圆头 **OSTMSP27**
- 骨挤压器3.2 mm,弯,圆头 **OSTMSP32**
- 骨挤压器3.7 mm,弯,圆头 **OSTMSP37**
- 骨挤压器4.2 mm,弯,圆头 **OSTMSP42**
- 骨挤压器5.0 mm,弯,圆头 **OSTMSP50**



Osteotome 骨挤压器, 弯, 尖端微凸

- 骨挤压器2.7 mm,弯,圆头 **OSTMSP27A**
- 骨挤压器3.2 mm,弯,圆头 **OSTMSP32A**
- 骨挤压器3.7 mm,弯,圆头 **OSTMSP37A**
- 骨挤压器4.2 mm,弯,圆头 **OSTMSP42A**
- 骨挤压器5.0 mm,弯,圆头 **OSTMSP50A**

牙龈刀



3/4 Buck 双头牙龈刀
#6 号柄 **KB3/46**



5/6 Buck 双头牙龈刀
#6 号柄 **KB5/66**



CK-3 Crane-Kaplan 双头牙龈刀
#6 号柄 **KCK36**
#2 号柄 **KCK3**

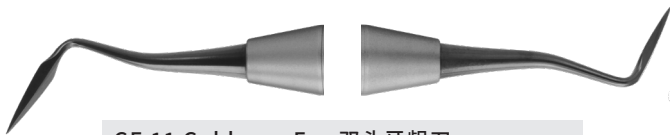

GF-11 Goldman-Fox 双头牙龈刀
黑金系列 **KGF11X**
#6 号柄 **KGF116**

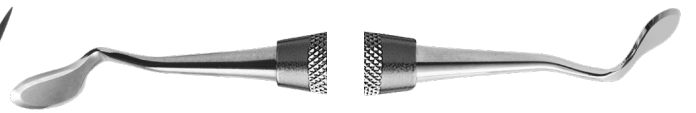

GF-7 Goldman-Fox 双头牙龈刀
#6 号柄 **KGF76**

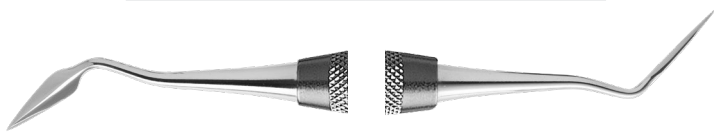

GF-8 Goldman-Fox 双头牙龈刀
#6 号柄 **KGF86**



GF-9 Goldman-Fox 双头牙龈刀
#6 号柄 **KGF96**



15/16 Kirkland 双头牙龈刀
黑金系列 **KK15/16X**
黑金系列短柄 **KK15/16SX**
#6 号柄 **KK15/166**
#6 号短柄 **KK15/16S6**
#9 号柄 **KK15/169**

15K Kirkland 单头牙龈刀
#6 号柄 **KK156**
#2 号柄 **KK15**

16K Kirkland 单头牙龈刀
#6 号柄 **KK166**
#2 号柄 **KK16**



11 Kramer-Nevins 双头牙龈刀
#6 号柄 **KKN116**



7 Kramer-Nevins 双头牙龈刀
#6 号柄 **KKN76**



1/2 Orban 双头牙龈刀
黑金系列 **KO1/2X**
#6 号柄 **KO1/26**
#9 号柄 **KO1/29**

1 Orban 单头牙龈刀
#6 号柄 **KO16**
#2 号柄 **KO1**



Allen Arrowhead 牙龈刀
#9 号柄 **KO12KP3R49**
黑金系列 **KO12KP3R4X**

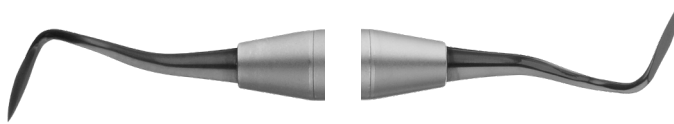

1/2 Allen Orban 牙龈刀
黑金系列 **KO12KPO3AX**
#6 号柄 **KO12KPO3A6**
#9 号柄 **KO12KPO3A9**

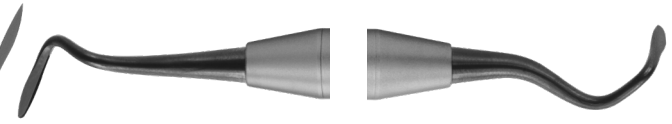

1/2 改良版 Allen Orban 牙龈刀
黑金系列 **KO12KPO3RX**
#6 号柄 **KO12KPO3AR**
#9 号柄 **KO12KPO3R9**



Allen 牙龈刀 (末端刃口)
黑金系列 **KPAX**
#6 号柄 **KPA**



1 Dr. Reddy 牙龈刀
#6 号柄 **KRDY1**

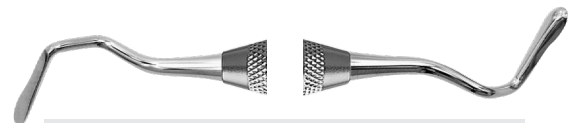

2 Dr. Reddy 牙龈刀
#6 号柄 **KRDY2**



1/2 Sanders 双头牙龈刀
#6 号柄 **KS1/26**



1/2 Solt Gingivectomy 双头牙龈刀
#6 号柄 **KSOLT1/26**



19/20 USC Towner 双头牙龈刀
#6 号柄 **KUSC6**



PM Nanos A Perio 牙龈刀,带角度
光滑柄 **PMNANOAS**



PM Nanos S Perio 牙龈刀,直
光滑柄 **PMNANOSS**

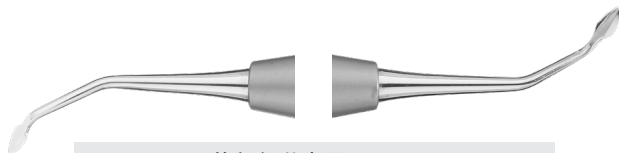

Steigmann 软组织分离器
光滑柄 **TKSTEIG**

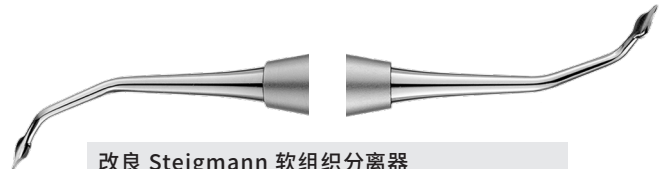

改良 Steigmann 软组织分离器
光滑柄 **TKSTEIG2**

隧道刀

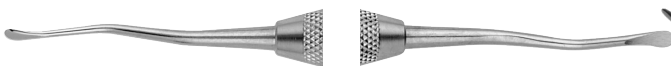

1 隧道刀
黑金系列 **TKN1X**
黑金系列,短柄 **TKN1SX**
#6 号柄 **TKN1**
#6 号短柄 **TKN1S6**
光滑柄 **TKN1CH**

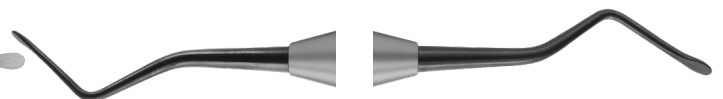

2 隧道刀
黑金系列 **TKN2X**
黑金系列,短柄 **TKN2SX**
#6 号柄 **TKN2**
#6 号短柄 **TKN2S6**
光滑柄 **TKN2CH**

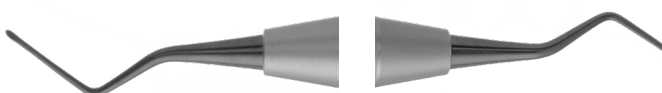

GDQ 隧道刀 1
黑金系列 **FQUINCEY1X**

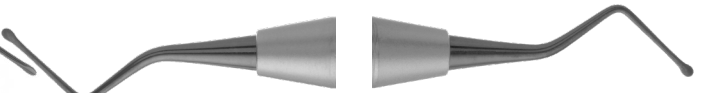

GDQ 隧道刀 2
黑金系列 **FQUINCEY2X**



骨锤

尼龙面 (#1 骨锤配件)

PTNFM1



#1 Mead 免疫钢骨锤

MAL1



开口器

硅橡胶替换配件

成人 **PTRTA**

儿童 **PTRTC**

婴儿 **PTRTI**

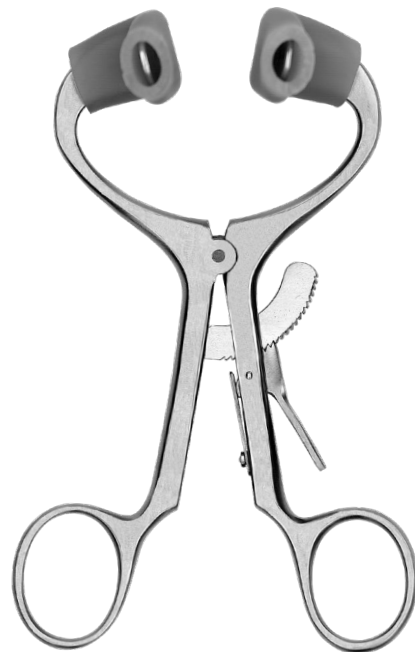

Molt 开口器

成人 **MGA**

儿童 **MGC**

婴儿 **MGI**



橡胶咬合器

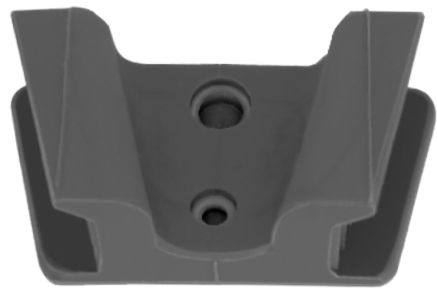

橡胶咬合器

1对

儿童小号

MP48

儿童

MP52

成人

MP54

持针器

Perma Sharp™ 持针器

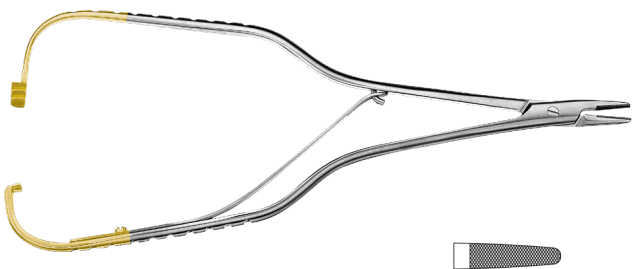

Arruga Perma Sharp™ 持针器

16 cm

NH5022

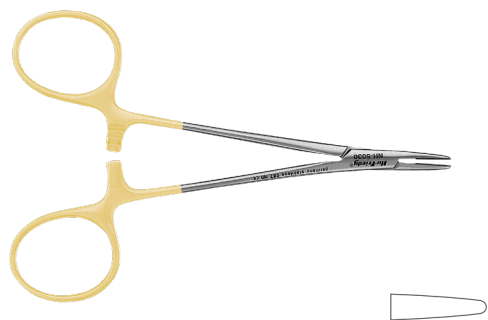

Webster Perma Sharp™ 持针器

11.5 cm

NH5030

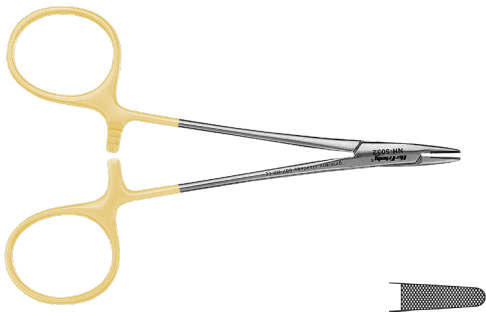

Derf Perma Sharp™ 持针器

11.5 cm

NH5032



Perma Sharp™ Hegar-Baumgartner 持针器

14 cm

NH5034

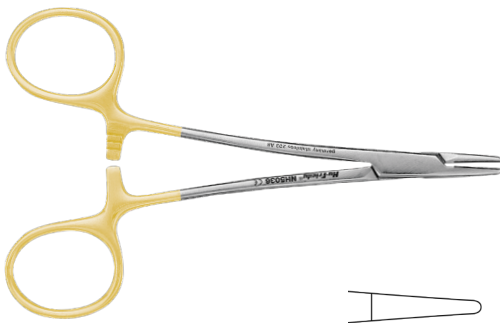

Halsey Perma Sharp™ 持针器, 光滑

13 cm

NH5036



Perma Sharp™ Halsey 持针器, 有锯齿

13 cm

NH5037



Crile-Wood Perma Sharp™ 持针器

15 cm

NH5038



Perma Sharp™ Crile-Wood 持针器, 左利手

15 cm

NH5038L

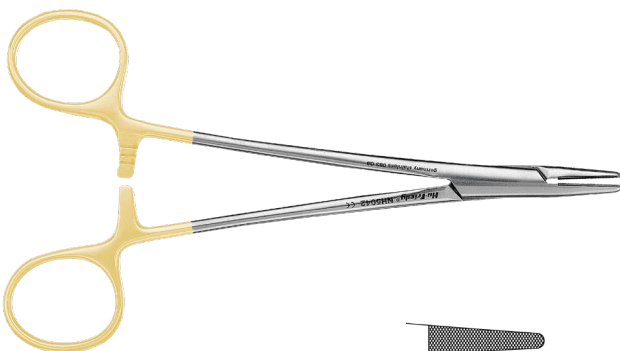

Mayo-Hegar Perma Sharp™ 持针器

16 cm

NH5042

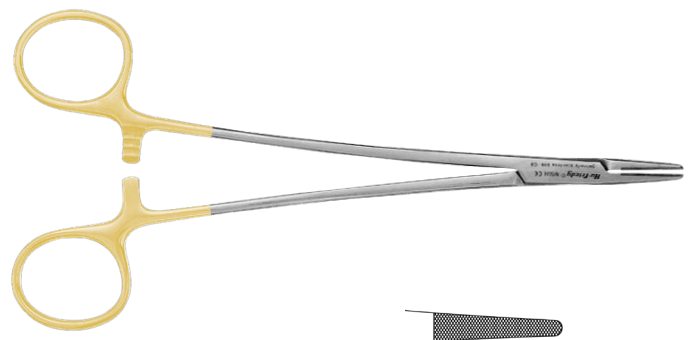

Mayo-Hegar Perma Sharp™ 持针器

18 cm

NH5044



DeBakey Perma Sharp™ 持针器
18 cm **NH5046**

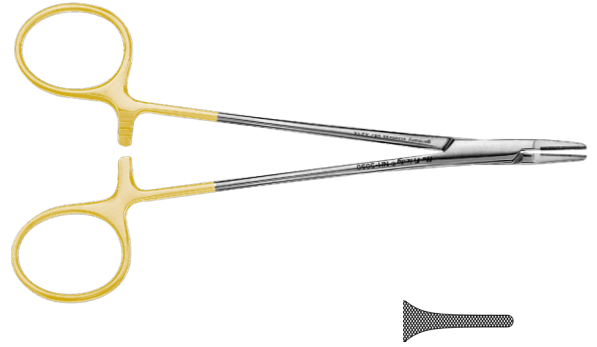

HMT Perma Sharp™ 持针器
15 cm **NH5050**

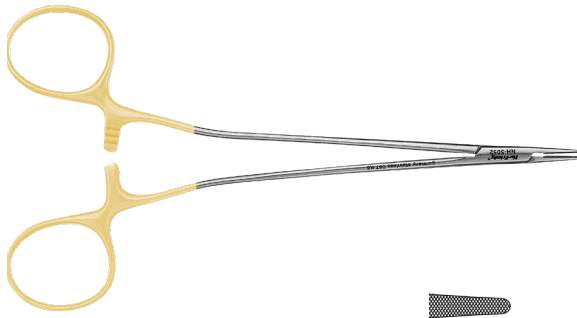

Fine Swedish Pattern Perma Sharp™ 持针器
15 cm **NH5052**



Olsen-Hegar Perma Sharp™ 持针器
17 cm **NH5068**

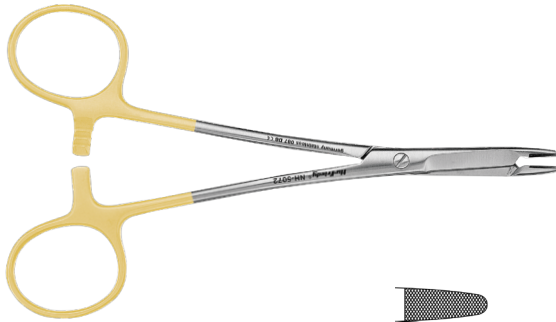

Olsen-Hegar Perma Sharp™ 持针器
14 cm **NH5072**



Mathieu-Kocher Perma Sharp™ 持针器
14 cm **NH5074**



Mathieu-Kocher Perma Sharp™ 持针器
14 cm **NH5074E**



Mathieu Perma Sharp™ 持针器
14 cm **NH5076**

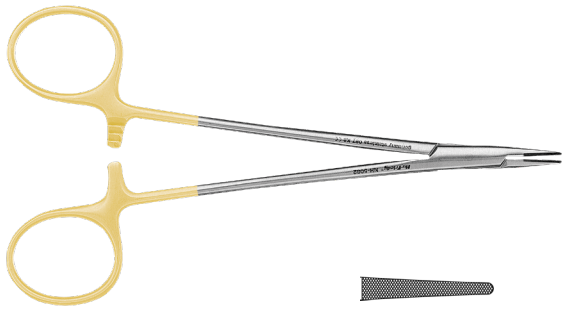

Micro-Vascular Pattern Perma Sharp™ 持针器
15 cm **NH5082**

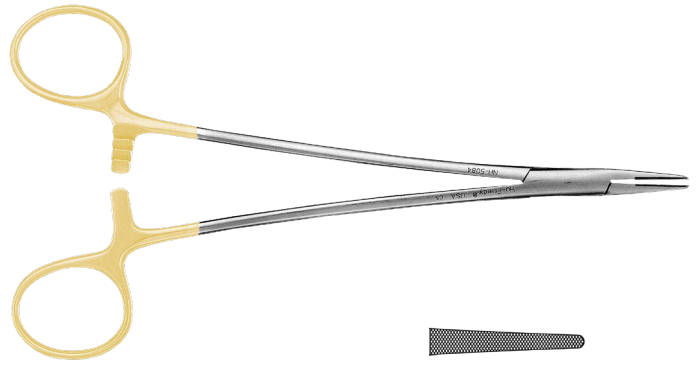

Micro-Vascular Pattern Perma Sharp™ 持针器
18 cm **NH5084**



Mini-Ryder Perma Sharp™ 持针器
15 cm **NH5092**

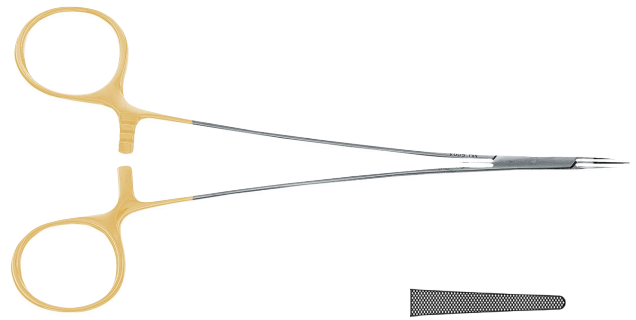

Mini-Ryder Perma Sharp™ 持针器
18 cm **NH5094**



Lichtenberg Perma Sharp™ 持针器
17 cm **NHLBPSB**

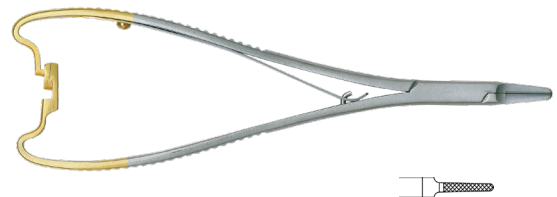

Lichtenberg Perma Sharp™ 持针器
17 cm **NHLBPSE**

Perma Sharp™ Castroviejo 持针器

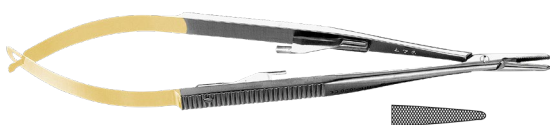

Perma Sharp™ Castroviejo 持针器, 直头
5-0, 6-0, 7-0, 8-0
14 cm **NH5020**



Perma Sharp™ Castroviejo 持针器, 弯头
圆柄 5-0, 6-0, 7-0, 8-0
14 cm **NH5020R**



Perma Sharp™ Castroviejo 持针器, 弯头
5-0, 6-0, 7-0, 8-0
14 cm **NH5021**



Perma Sharp™ Castroviejo 持针器, 弯头
圆柄
14 cm **NH5021RC**

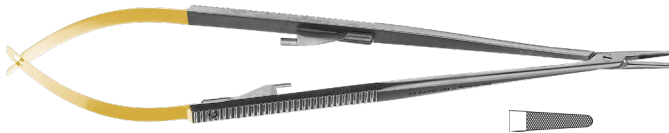

Perma Sharp™ Castroviejo 持针器, 平头
5-0, 6-0, 7-0, 8-0, 9-0, 10-0
18 cm **NH5024**



Perma Sharp™ Castroviejo 持针器, 圆头
圆柄 5-0, 6-0, 7-0, 8-0, 9-0, 10-0
18 cm **NH5024R**



Perma Sharp™ Castroviejo 持针器, 弯头圆柄
5-0, 6-0, 7-0, 8-0, 9-0, 10-0
18 cm **NH5024RC**



Simion Perma Sharp™ Castroviejo 持针器
3-0, 4-0, 5-0, 6-0
18 cm **NH5024SIM**

显微持针器



Castroviejo 显微持针器, 直头
5-0, 6-0, 7-0, 8-0
14 cm **NH5020M**



Castroviejo 显微持针器, 弯头
5-0, 6-0, 7-0, 8-0
14 cm **NH5021M**



Cortellini Castroviejo 显微持针器, 直头
圆柄 5-0, 6-0, 7-0, 8-0, 9-0, 10-0
18 cm **NH5024CORT**



金刚砂镀层 Castroviejo 显微持针器, 直头
圆柄 5-0, 6-0, 7-0, 8-0, 9-0, 10-0
15 cm **NHM-5025R**



金刚砂镀层 Castroviejo 显微持针器, 直头
圆柄 5-0, 6-0, 7-0, 8-0, 9-0
18 cm **NHM-5026R**



Schlee 显微持针器
NHLSCHLEE



Castroviejo 显微持针器



Castroviejo 显微持针器
5-0, 6-0, 7-0, 8-0
14 cm **NHCV**
18 cm **NHCV18**

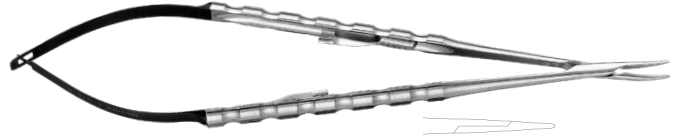

金刚砂镀层 Castroviejo 显微持针器, 直头
6-0, 7-0, 8-0
18 cm **NHDCPV**

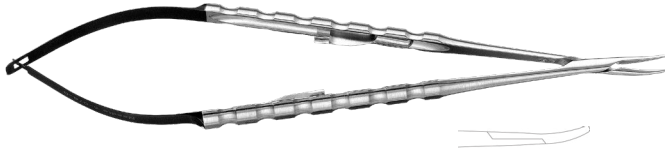

金刚砂镀层 Castroviejo 显微持针器, 弯头
6-0, 7-0, 8-0
18 cm **NHDCPVN**



金刚砂镀层 Castroviejo 显微持针器, 直头
6-0, 7-0, 8-0
18 cm **NHDPV**

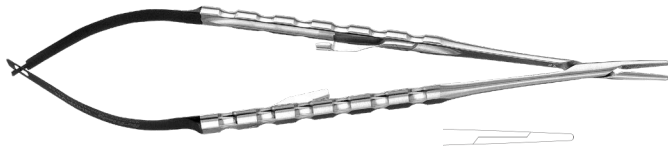

金刚砂镀层 Castroviejo 显微持针器, 直头
4-0, 5-0, 6-0
18 cm **NHDPVN**



Castroviejo 显微持针器, 弯头
6-0, 7-0, 8-0, 9-0, 10-0, 11-0
13 cm **NHM-5027**



Castroviejo 显微持针器, 直头
6-0, 7-0, 8-0, 9-0, 10-0, 11-0
13 cm **NHM-5028**



金刚砂镀层 Castroviejo 显微持针器 (钛)
6-0, 7-0, 8-0, 9-0, 10-0
18 cm **NHTMBH**



Swis Perio 显微持针器
5-0, 6-0, 7-0, 8-0, 9-0
18 cm **SPNHDPVN**

通用持针器



Collier 持针器
3-0, 4-0, 5-0, 6-0
12 cm **NHC**



Crile-Wood 持针器
3-0, 4-0, 5-0, 6-0
15 cm **NHCW**



Derf 持针器
3-0, 4-0, 5-0, 6-0
12 cm **NHD**

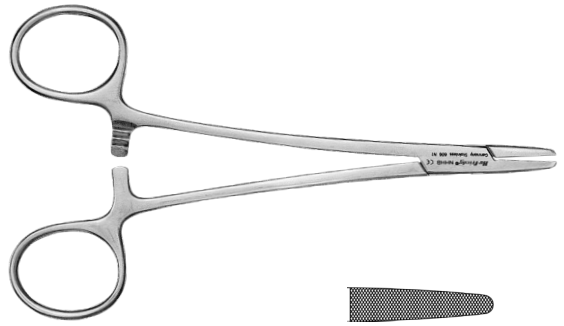

Hegar-Baumgartner 持针器
1-0, 2-0, 3-0, 4-0
14.5 cm **NHHB**



Mathieu 持针器
1-0, 2-0, 3-0, 4-0
14 cm **NHM**

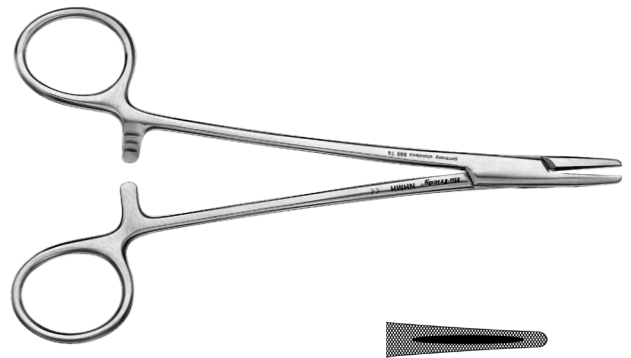

Mayo-Hegar 持针器
1-0, 2-0, 3-0, 4-0
16 cm **NHMH**

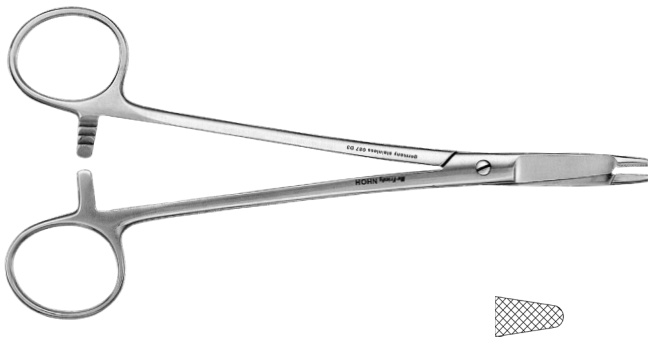

Olsen-Hegar 持针器/剪
4-0, 5-0, 6-0
17 cm **NHOH**



Webster 持针器
7-0, 8-0, 9-0, 10-0
13.25 cm **NHW**



Gillies Fine 持针器
NHGILFINE

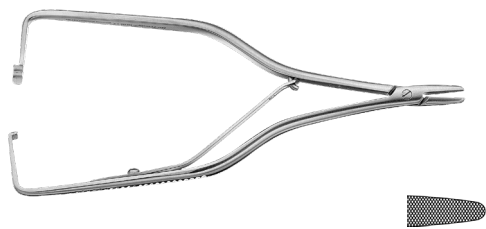

Boynton (Hu-Friedy) 持针器
5-0, 6-0, 7-0
12 cm **NHB**

骨膜分离器



4 Hoexter 骨膜分离器

#6 号柄

HOEXTER4



1 Hopkins 骨膜分离器

#6 号柄

P1H6



12S Bennett 骨膜分离器

#6 号柄

P12S6

#522 号柄

P12S



14 Goldman-Fox 骨膜分离器

黑金系列

P14X

#6 号柄

P146

#2 号柄

P14



149 骨膜分离器

#6 号柄	P1496
#522 号柄	P149



15 Freer 骨膜分离器

#6 号柄	P156
#522 号柄	P15



16 Freer 骨膜分离器

#6 号柄	P166
#522 号柄	P16



1 Hopkins 骨膜分离器

#6 号柄	P1H6
-------	-------------



2 Hopkins 骨膜分离器

#6 号柄	P26
#522 号柄	P2



20 (LH) Hirschfeld 骨膜分离器

#6 号柄	P206
#2 号柄	P20



20 Sicilia 骨膜分离器

#6 号柄	P20SIC6
#2 号柄	P20SIC

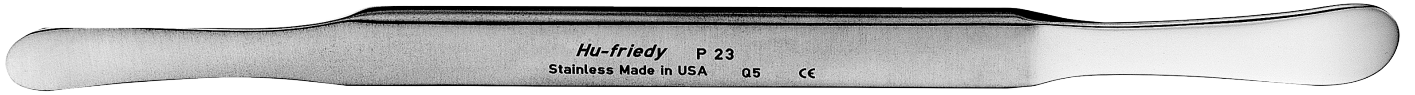

23 Seldin 骨膜分离器/拉钩

P23



24G Sicilia 骨膜分离器

#6 号柄 **P24GSIC6**

#522 号柄 **P24GSIC**



24G 骨膜分离器

黑金系列, 短柄 **P24GSPX**

#6 号柄 **P24GSP6**

#5 号柄 **P24GSP**

#2 号柄 **P24G**



3 Mead 骨膜分离器

#6 号柄 **P36**

#522 号柄 **P3**



5 Molt 单头骨膜分离器

#502 号柄 **P5**



8D 双头骨膜分离器

#6 号柄 **P8D6**

#522 号柄 **P8D**



9 Molt 骨膜分离器	
黑金系列	P9X
#6 号柄	P96
#522 号柄	P9



P9/PA 双头骨膜分离器	
#6 号柄	P9/PA6
#522 号柄	P9/PA



9A Allen 骨膜分离器	
#6 号柄	P9A6
#522 号柄	P9A



9H Howard 骨膜分离器	
#6 号柄	P9H6
#522 号柄	P9H



Benque 骨膜分离器	
#6 号柄	PBQ6
#522 号柄	PBQ



Demirel 骨膜分离器	
#6 号短柄	PDEMIRELS6



Donos 骨膜分离器	
黑金系列	PDONOS



Urban Mini Me 显微骨膜分离器

黑金系列	PFIWDS1MKX
#6 号柄	PFIWDS1MK



Woodson 骨膜分离器

黑金系列	PFIWDS1X
#6 号短柄	PFIWDS1S6

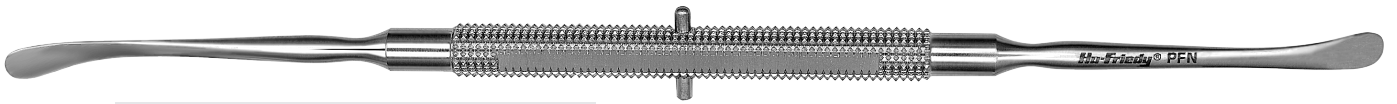

Freer Nasal 骨膜分离器

PFN



Grisdale 骨膜分离器

#6 号柄	PGR1
-------	-------------



1 Hourigan 骨膜分离器/拉钩 带锯齿

PH1



2 Hourigan 骨膜分离器

改良版	PH26M
#6 号柄	PH26
#41 号柄	PH2



#2 Kalla 骨膜分离器

PH2KALLA



1 Kramer-Nevins 骨膜分离器

- | | |
|--------|--------------|
| #6 号柄 | PKN16 |
| #41 号柄 | PKN1 |



152 Kramer-Nevins 骨膜分离器

- | | |
|-------|----------------|
| #6 号柄 | PKN1526 |
| #2 号柄 | PKN152 |



152 Kramer-Nevins 骨膜分离器

- | | |
|----------|-----------------|
| 黑金系列 | PKN152X |
| 黑金系列, 短柄 | PKN152SX |



Malo 骨膜分离器

PMALO



PM Split 骨膜分离器

- | | |
|----------|------------------|
| 黑金系列, 短柄 | PMSPLITSX |
|----------|------------------|

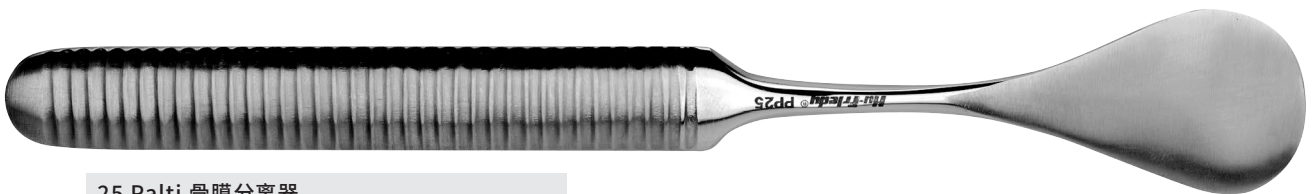

25 Palti 骨膜分离器

PP25



Implant 骨膜分离器

- | | |
|-------|------------------|
| #6 号柄 | PP5590SIM |
|-------|------------------|



骨膜分离器/Allen 后牙挺	
黑金系列	PPAELPX
黑金系列, 短柄	PPAELPSX
#6 号柄	PPAELP
#6 号短柄	PPAELS6



骨膜分离器/Allen 前牙挺	
黑金系列	PPAELAX
黑金系列, 短柄	PPAELASX
#6 号柄	PPAELA
#6 号短柄	PPAELAS6



骨膜分离器/Allen 牙挺	
黑金系列	PPAELX
黑金系列, 短柄	PPAELSX
#6 号柄	PPAEL



改良版 Buser/Hourigan 小号骨膜分离器	
黑金系列	PPBUH2M2X

改良版 Buser/Hourigan 大号骨膜分离器	
黑金系列	PPBUH2MX



1/2 Buser 改良版 PJO1/2 & Chisel 13KL 骨刮器	
#6 号柄	PPBUSE1/26



1/3 Buser 改良版 PJO1/3 & Chisel 13KL 骨刮器	
#6 号柄	PPBUSE1/36



Buser 骨膜分离器	
黑金系列	PPBUSERX
黑金系列, 短柄	PPBUSERSX
#6 号柄	PPBUSER6
#10 号柄	PPBUSER



1 Labanca 骨膜分离器

#6 号柄 [PPLABANCA6](#)

#10 号柄 [PPLABANCA](#)



2 Labanca 改良骨膜分离器

#6 号柄 [PPLABANC26](#)

#6 号短柄 [PPLABAN2S6](#)

#41 号柄 [PPLABANCA2](#)



3 Labanca 改良骨膜分离器

黑金系列 [PPLABANC3X](#)

#6 号柄 [PPLABANC36](#)

#41 号柄 [PPLABANCA3](#)



#3/9A 骨膜分离器

#6 号柄 [PPR3/9A6](#)

#522 号柄 [PPR3/9A](#)



PR-3 Prichard 骨膜分离器

黑金系列 [PPR3X](#)

#6 号柄 [PPR36](#)

#6 号短柄 [PPR3S6](#)

#522 号柄 [PPR3](#)

#522 号短柄 [PPR3S](#)

改良版 [PPR3M](#)



Spahr Papilla 骨膜分离器

#6 号柄 [PPSPAHR6](#)



Steigmann 骨膜分离器
光滑柄 **PPSTEIG**



1 Trombelli 骨膜分离器
#6 号柄 **PTROM16**

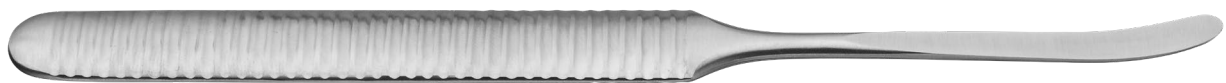

Williger 骨膜分离器, 大号
PWILL



Swiss Perio SIC 骨膜分离器
黑金系列 **SPP24GSICX**



Swiss Perio 骨膜分离器
黑金系列 **SPP24GSP2X**



Swiss Perio 24G骨膜分离器
黑金系列 **SPP24GSPX**



Swiss Perio PH2 骨膜分离器
黑金系列 **SPPH2X**



Swiss Perio SCHL 骨膜分离器
黑金系列 **SPPSCHLEEX**

牙龈分离器



牙龈分离器, 后牙
黑金系列 **PT1X**

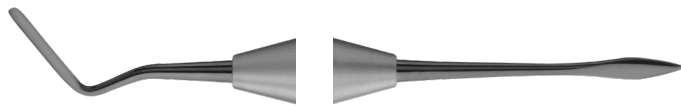

牙龈分离器, 前牙
黑金系列 **PT2X**



牙龈分离器, 右侧后牙
黑金系列 **PT3X**



牙龈分离器, 左侧后牙
黑金系列 **PT4X**



牙龈分离器, 前牙
黑金系列 **PT5X**



牙龈分离器, 前牙
黑金系列 **PT6X**



Wise 牙龈分离器
黑金系列 **PEREURX**

拉钩

颊侧拉钩



Bishop 颊侧拉钩

CRB



Black 颊侧拉钩

CRBL



Columbia 颊侧拉钩

CRC



明尼苏达拉钩

黑金系列

CRMX

不锈钢

CRM



Cawood-Minnesota 拉钩

CRM2



Simion 颊侧拉钩

CRMS



改良 Minnesota 拉钩, 有锯齿

CRMT



Urban 颊侧拉钩

CRURBAN



Labanca Malleable 拉钩
3 支 **CRLABANCA**



Orringer 拉钩
中号 **CRO2**
大号 **CRO3**



塑料拉钩
1 对
成人 **CRPA**
儿童 **CRPC**

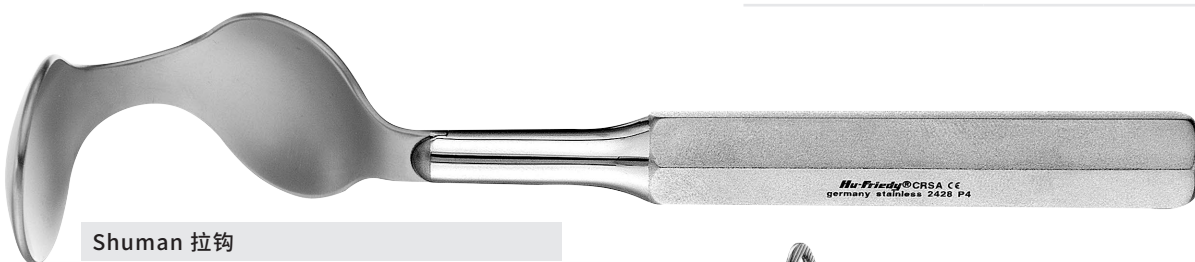

Shuman 拉钩
成人 **CRSA**



Farabeuf 组织拉钩
TRFB



Weider 颊/舌拉钩
小号 **CRW1**
大号 **CRW2**

组织拉钩



上颌窦拉钩

#504 号柄

SGRT

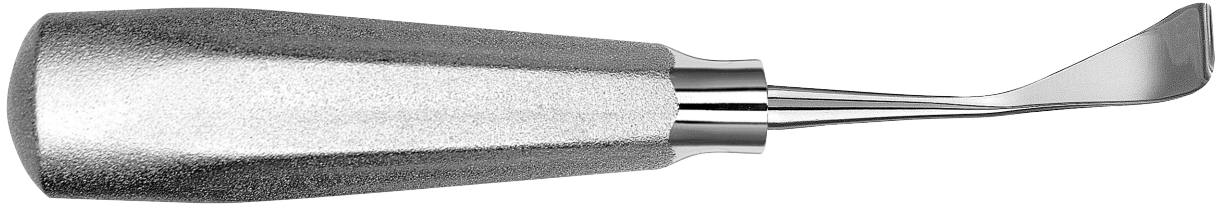

Brener 上颌窦拉钩

#510 号柄

SGRTB



50 Channel 拉钩

SR50



8 外科拉钩

SR8



9 Ramus 拉钩

SR9

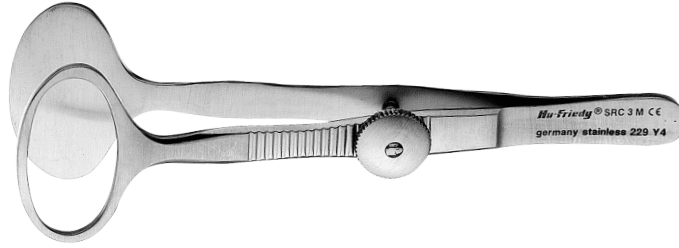

Desmarres Chalazion 拉钩, 中号

SRC3M

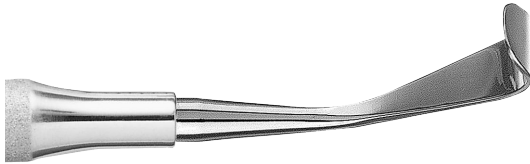

Misch 10 上颌窦拉钩

SRM10

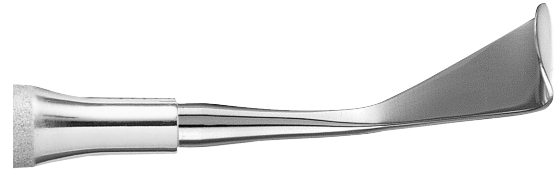

Misch 15 上颌窦拉钩

SRM15

Henahan 拉钩



1 Henahan 拉钩, 左侧

TRH1



2 Henahan 拉钩, 中间

TRH2



2/3 Henahan 拉钩, 右侧

TRH2/3



3 Henahan Retractor, Right

TRH3



牵开器
23 cm **IR**



Middeldorpf 牵开器
17 cm x 14 cm **RSMID1**



Middeldorpf 拉钩
22 cm x 20 cm **RSMID2**



Malo 外科拉钩
SRMALO



1 外科拉钩
7 x 25 mm **SR1**

2 外科拉钩
10 x 42 mm **SR2**

3 外科拉钩
12 x 55 mm **SR3**



2 Austin 组织拉钩
TRA2

咬骨钳



1 Hu-Friedy 咬骨钳
16.5 cm **R1**



15 Hu-Friedy 咬骨钳
16.5 cm **R15**



18 Hu-Friedy咬骨钳
16.5 cm **R18**



1A Mead 咬骨钳

16.5 cm

R1A



3H Dean 咬骨钳

17 cm

R3H



4 Cleveland咬骨钳

14 cm

R4



4A Cleveland 咬骨钳

17 cm

R4A



5 咬骨钳

17 cm

R5



5S Cleveland 咬骨钳

15 cm

R5S



Kramer-Nevins 咬骨钳

14.5 cm

RKN



Blumenthal 咬骨钳

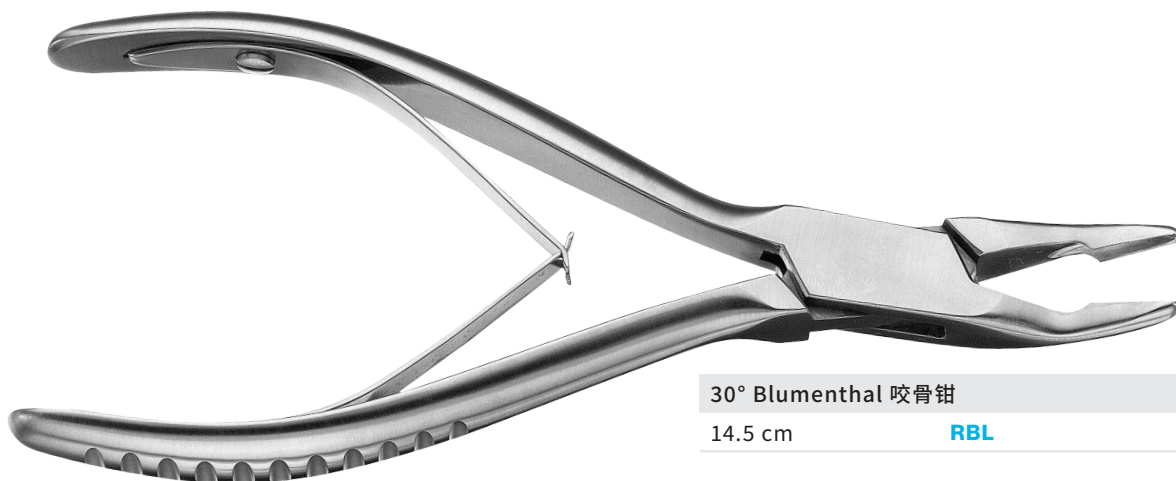

30° Blumenthal 咬骨钳

14.5 cm

RBL

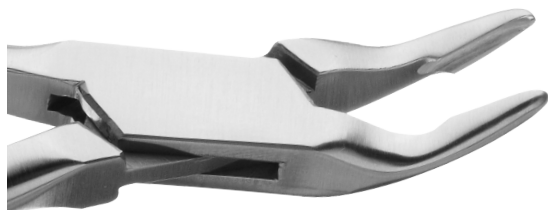

45° Blumenthal 咬骨钳

14.5 cm

RBL45



90° Blumenthal 咬骨钳

14.5 cm

RBL90

双关节咬骨钳

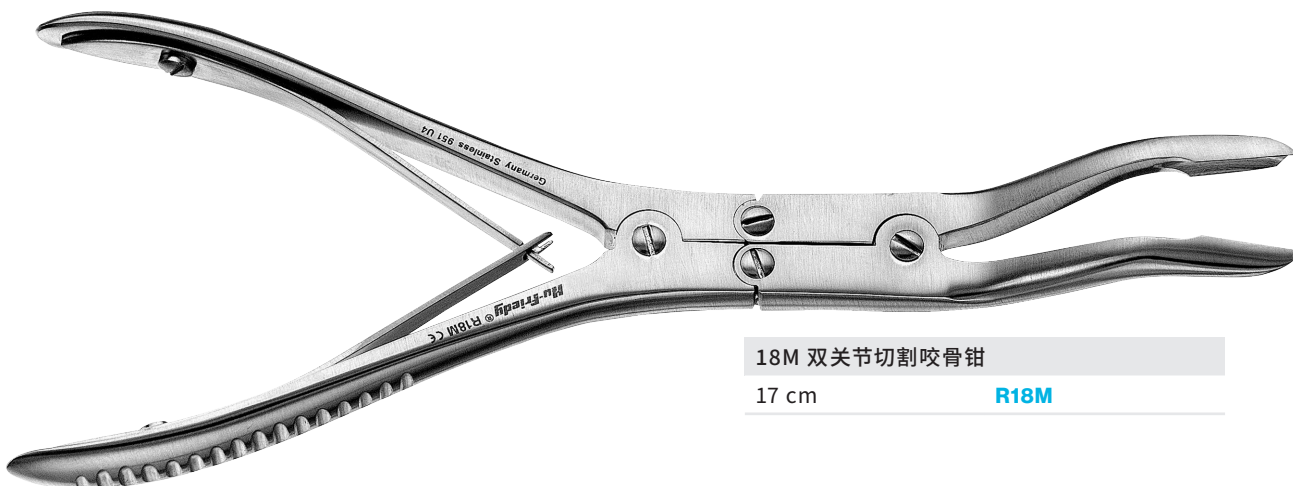

18M 双关节切割咬骨钳

17 cm

R18M

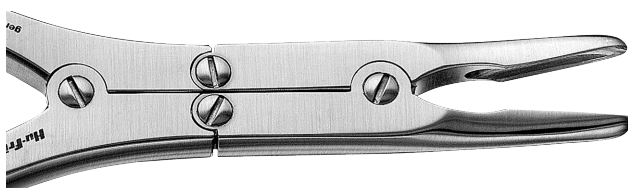

Beyer 咬骨钳

18 cm

RBEY

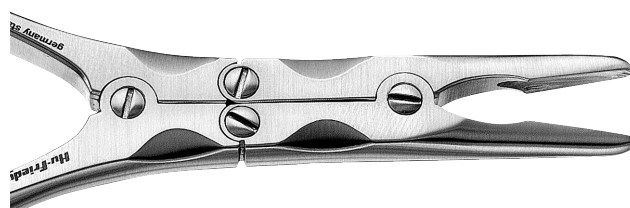

Boehler 咬骨钳

16 cm

RBOE

15 cm, 有曲度

RBOEC

Friedman 咬骨钳



Friedman 咬骨钳

14 cm

RF



Mini Friedman 咬骨钳

14.5 cm

RMF



Mini 90° Friedman 咬骨钳

14.5 cm

RMF90



Kerrison Shortnose 咬骨钳, 3 mm

RKS-N



根尖挺

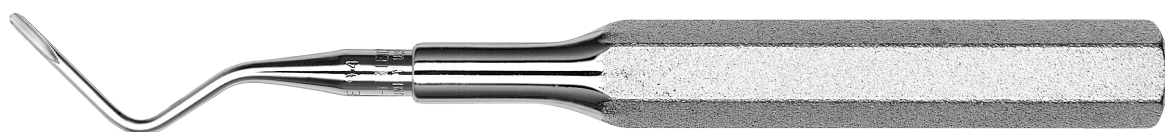

#94 根尖挺
#502 号柄 **E94**



#95 根尖挺
#502 号柄 **E95**

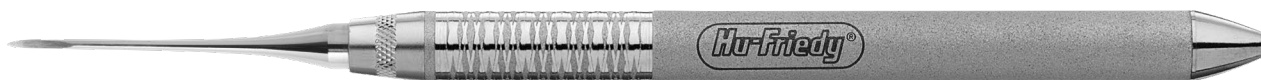

9 West 根尖挺
#6 号柄 **E96**
#503 号柄 **E9**



9L 根尖挺
#6 号柄 **E9L6**
#503 号柄 **E9L**



9R 根尖挺
#6 号柄 **E9R6**
#503 号柄 **E9R**



10 Davis 根尖挺, 双头
#6 号柄 **ED106**
#2 号柄 **ED10**



11 Davis 根尖挺, 双头
#6 号柄 **ED116**
#503 号柄 **ED11**



1 Davis 根尖挺, 单头
#6 号柄 **ED16**
#503 号柄 **ED1**



2 Davis 根尖挺, 单头
#6 号柄 **ED26**
#503 号柄 **ED2**

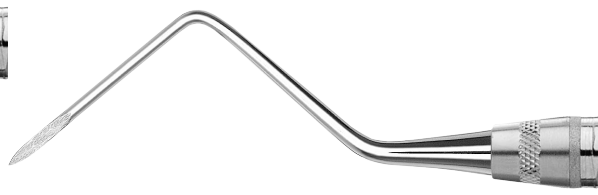

3 Davis 根尖挺, 单头
#6 号柄 **ED36**
#503 号柄 **ED3**

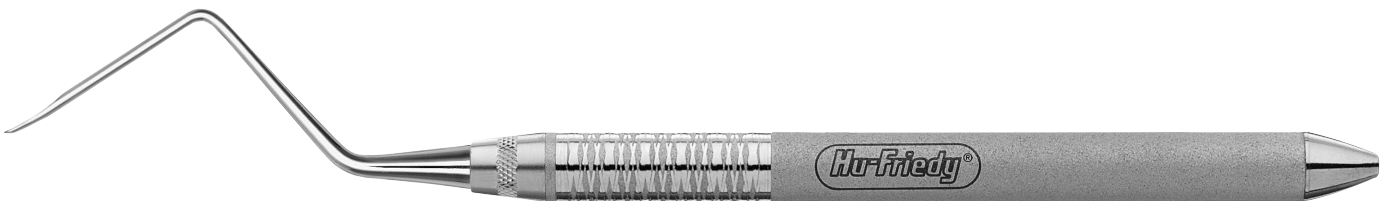

4 Davis 根尖挺, 单头
#6 号柄 **ED46**
#503 号柄 **ED4**



#1 Heidbrink 根尖挺
#502 号柄 **EHB1**



13/14 Heidbrink 根尖挺
 黑金系列 **EHB13/14X**
 #6 号柄 **EHB13/146**
 #522 号柄 **EHB13/14**

13/14 Heidbrink 根尖挺, 加硬
 #6 号柄 **EHB13/14H6**
 #522 号柄 **EHB13/14H**



2 Heidbrink 根尖挺
 #502 号柄 **EHB2**
 2 Heidbrink 根尖挺, 加硬
 #502 号柄 **EHB2H**



3 Heidbrink 根尖挺
 #502 号柄 **EHB3**
 3 Heidbrink 根尖挺, 加硬
 #502 号柄 **EHB3H**



4 Heidbrink 根尖挺
 #502 号柄 **EHB4**



5 Heidbrink 根尖挺
 #502 号柄 **EHB5**



1 Howard 根尖挺
 #502 号柄 **EHO1**



2 Howard 根尖挺
 #502 号柄 **EHO2**



2/3 Howard 根尖挺
 #6 号柄 **EHO2/36**
 #522 号柄 **EHO2/3**

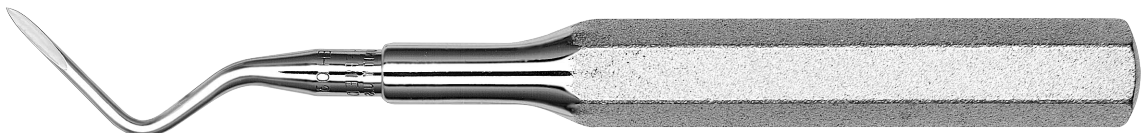

#3 Howard 根尖挺
 #502 号柄 **EHO3**



#4 Howard 根尖挺
 #502 号柄 **EHO4**



RAF1 根尖挺
 #504 号柄 **ERAF1**



RAF3 改良版根尖挺

#504 号柄

ERAF3KA



1 West Apical 根尖挺

#6 号柄

EWS16

#1 号柄

EW1



2 West Apical 根尖挺

#6 号柄

EW26

#1 号柄

EW2



3 West Apical 根尖挺

#6 号柄

EW36

#1 号柄

EW3



4 West Apical 根尖挺

#6 号柄

EW46

#1 号柄

EW4



5 West Apical 根尖挺

#6 号柄

EW56

#1 号柄

EW5



6 West Apical 根尖挺

#6 号柄

EW66

#1 号柄

EW6

手术刀柄

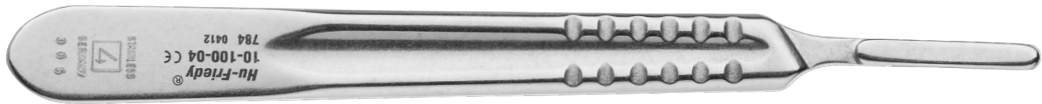

#4 手术刀柄

10-100-04



#3 手术刀柄

10-130-03

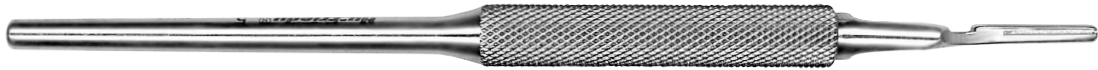

#5 手术刀柄, 圆柄直头

10-130-05

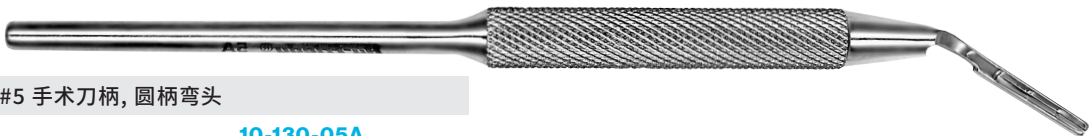

#5 手术刀柄, 圆柄弯头

10-130-05A

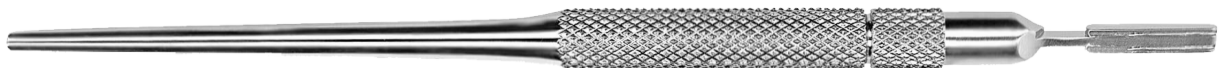

#5 S 手术刀柄, 双刀片

1 mm 1013005D1

1.5 mm 10-130-05D



#5 手术刀柄

10-130-05E



#7 手术刀柄

10-130-07

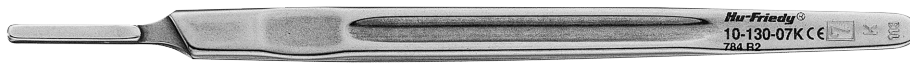

#7K 手术刀柄

10-130-07K



#5 欧式手术刀柄

10-130-5EM



360° 手术刀柄

K360

显微手术刀柄/口镜柄



显微手术刀柄/口镜柄

SHDPV



显微刀柄/口镜柄 (钛)

SHTMBH



ResinEight 显微手术刀柄

10-130-08



迷你刀片手术刀柄

1-015

附加产品



7 迷你手术刀柄

10-130-70



Paquette Palatal 弓形刀片手柄

KPQ

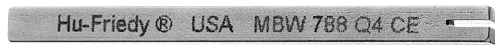

迷你和微型刀片扳手

MBW



刀片取出器

10-199-00

手术剪



1 Kelly 手术剪,弯头,单面锯齿刃口
16 cm **S1**

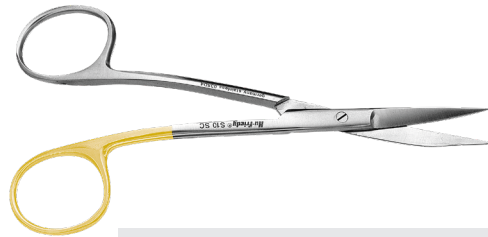

10 手术剪 13.5 cm
特殊锋利工艺 **S10SC**
标准 **S10**



11 Locklin 手术剪,单面锯齿刃口
16 cm **S11**



12 Locklin 手术剪,单面锯齿刃口
16 cm **S12**



13 线剪
15 cm **S13**



13S 线剪
12 cm **S13S**



14 LaGrange 手术剪, 弯头 11.5 cm
特殊锋利工艺, 单面锯齿刃口

黑金系列 **S14SCX**

标准 **S14SC**

14 LaGrange 手术剪 11.5 cm, 单面锯齿刃口

标准 **S14**



15 Sullivan 手术剪, 单面锯齿刃口

14 cm

S15



16 Iris 手术剪, 弯头 12.5 cm 特殊锋利工艺,
单面锯齿刃口

黑金系列 **S16SCX**

标准 **S16SC**

16 Iris 手术剪 12.5 cm

标准 **S16**



17 Iris 手术剪, 直头 11.5 cm 特殊锋利工艺,
单面锯齿刃口

黑金系列 **S17SCX**

标准 **S17SC**

17 Iris 手术剪, 直头 11.5 cm

标准 **S17**



18 Iris 手术剪, 弯头 11.5 cm 特殊锋利工艺,
单面锯齿刃口

黑金系列 **S18SCX**

标准 **S18SC**

18 Iris 手术剪, 弯头 11.5 cm, 单面锯齿刃口

标准 **S18**



Metzenbaum 手术剪 特殊锋利工艺,
单面锯齿刃口

14.25 cm

S19SCX



1L Kelly 手术剪, 弯头, 单面锯齿刃口

18 cm

S1L



2 Kelly 手术剪, 直头, 单面锯齿刃口

16 cm

S2



Goldman-Fox 手术剪，直头，特殊锋利工艺，单面锯齿刃口

13.5 cm **S20SCX**

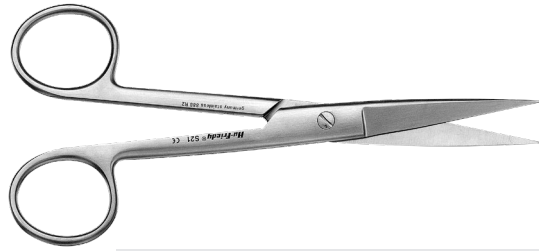

#21 手术剪，直头

14.5 cm **S21**



#22 手术剪，直头

14.5 cm **S22**



#23 手术剪，弯头

14.5 cm **S23**



2L Kelly 手术剪，直头，单面锯齿刃口

18 cm **S2L**



3 Mayo 弯剪

14.5 cm **S3**



4 Mayo 手术剪，直头

14.5 cm **S4**



Strabismus 手术剪，直头

11.5 cm **S40**



Strabismus 手术剪，弯头

11.5 cm **S41**



5 Wagner 手术剪, 直头, 单面锯齿刃口
11.5 cm **S5**



Kelly Perma Sharp™ 手术剪, 弯头,
单面锯齿刃口
16 cm **S5001**



Kelly Perma Sharp™ 手术剪, 直头,
单面锯齿刃口
16 cm **S5002**



Dean Perma Sharp™ 手术剪, 单面锯齿刃口
16 cm **S5009**

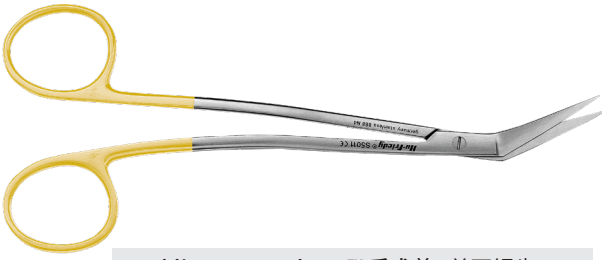

Locklin Perma Sharp™ 手术剪, 单面锯齿刃口
16 cm **S5011**



Locklin Perma Sharp™ 手术剪, 单面锯齿刃口
16 cm **S5012**



Metzenbaum Perma Sharp™ 手术剪, 直头
14.5 cm **S5054**



Metzenbaum Perma Sharp™ 手术剪, 弯头
14.5 cm **S5055**



Metzenbaum Perma Sharp™ 手术剪, 直头
14.5 cm **S5056**



Metzenbaum Perma Sharp™ 手术剪, 弯头
14.5 cm **S5057**



Metzenbaum Perma Sharp™ 手术剪, 弯头
18 cm **S5069**



Goldman-Fox Perma Sharp™ 手术剪, 直头
13 cm **S5080**



Goldman-Fox Perma Sharp™ 手术剪, 弯头, 单面锯齿刃口
13 cm **S5081**



Iris Perma Sharp™ 手术剪, 直头
11.5 cm **S5082**



Iris Perma Sharp™ 手术剪, 弯头
11.5 cm **S5083**



Wire Cutting Perma Sharp™ 手术剪, 单面锯齿刃口
12 cm **S5095**



6 Wagner 手术剪, 弯头, 单面锯齿刃口
11.5 cm **S6**



7 Wagner 手术剪, 有角度, 单面锯齿刃口
11.5 cm **S7**



8 Quinby 手术剪
12.5 cm **S8**



9 Dean 手术剪, 单面锯齿刃口
16.5 cm **S9**



金冠剪, 弯头
12 cm SCGC



Pedo 儿童金冠剪, 弯头
9 cm SCGCP



金冠剪, 直头
12 cm SCGS



Cortellini 手术剪, 弯头
12 cm SCORT



Cortellini 手术剪, 弯头, 特殊锋利工艺
12 cm SCORTSC



Joseph 手术剪 14 cm (5"), 单面锯齿刃口
弯头 SJC
直头 SJS



Lister Bandage Scissors
14.5 cm SLB



Baby Metzenbaum 手术剪
12.5 cm SMB

显微手术剪



Castroviejo 显微手术剪, 单面锯齿刃口
黑金系列 16.25 cm **SPVX**

Castroviejo 显微手术剪, 单面锯齿刃口
标准 18 cm **SPV**

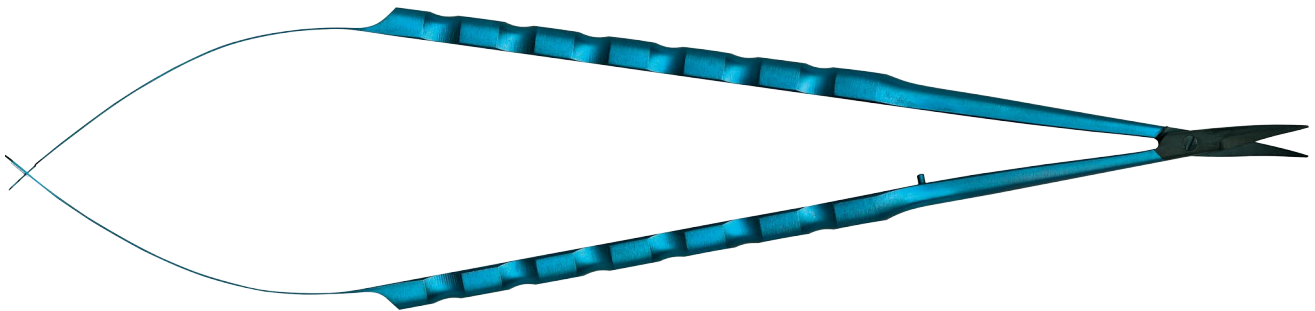

Castroviejo 显微手术剪 (钛)
钛 18 cm **STMBH**



31 Castroviejo 手术剪
10 cm **S31**



Swiss Perio 显微手术剪
12 cm **SPSPV**



Swiss Perio 显微手术剪, 45°, 单面锯齿刃口
12 cm **SPSPV45**

注射类器械



Aqua-Fix 冲洗器
21 cm **IS**

Aqua-Fix 注射头
PTIST

注射针帽放置器
STKSKLS



骨粉充填器
7 mm **SYBG**



Type A 注射器
1.8 ml **SYRA**



Cook-Waite 注射器
1.8 ml **SYRCW**

组织镊

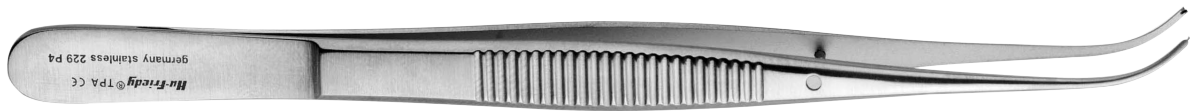

组织镊 1x2, 弯头纤细工作端
14.2 cm **TPA**

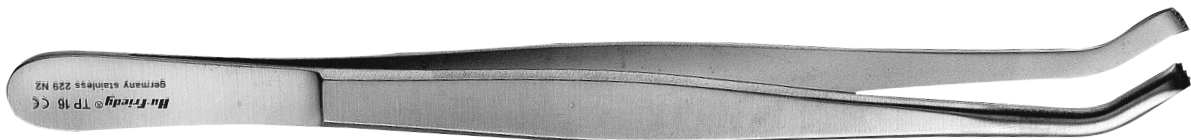

16 Hu-Friedy 组织镊
15 cm **TP16**

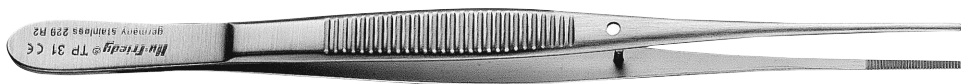

32 Semkin-Taylor 组织镊
12.5 cm, 直头 **TP31**
12.5 cm, 弯头 **TP32**

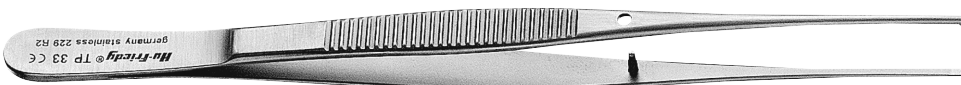

34 Semkin-Taylor 组织镊 1x2
12.6 cm, 直头 **TP33**
12.6 cm, 弯头 **TP34**

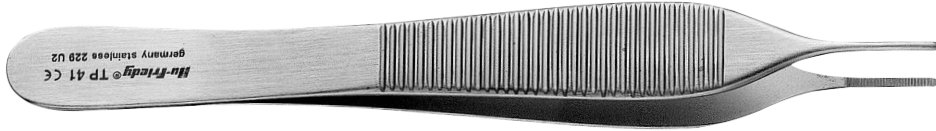

41 Adson Plain 组织镊
12 cm **TP41**

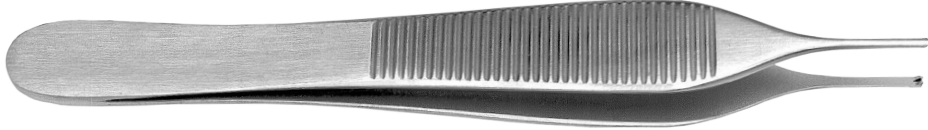

42 Adson 1x2 组织镊, 有齿
12 cm **TP42**



43 Adson-Brown 组织镊
12 cm, 直头 **TP43**
12 cm, 弯头 **TP43A**

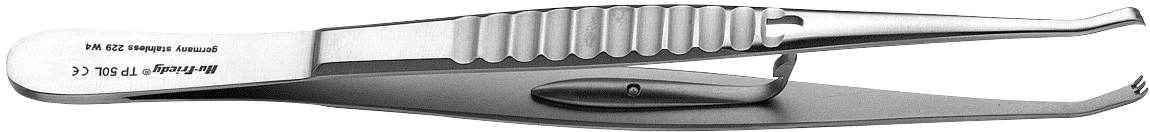

50 Fox 组织镊
15 cm, 锁镊 **TP50L**
15 cm, 非锁镊 **TP50**



Adson 1x2 组织镊
15 cm **TPA15**

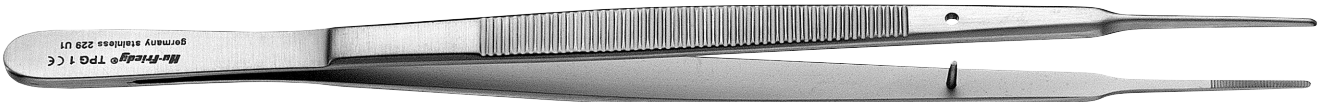

Gerald 组织镊, 直头含锯齿
18 cm **TPG1**

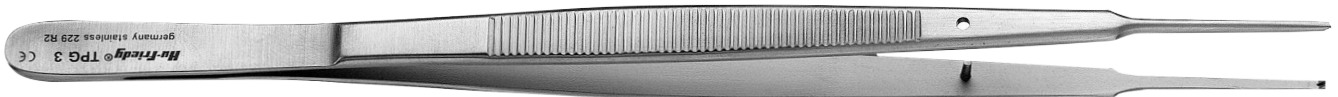

Gerald 1x2 组织镊, 直头
18 cm **TPG3**

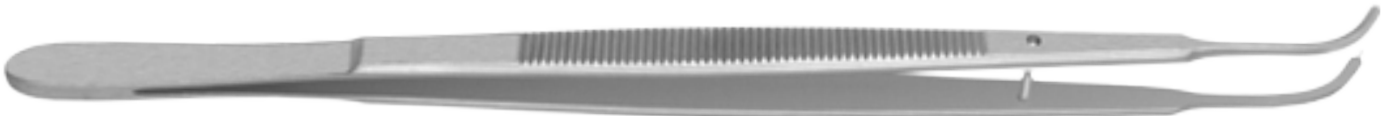

Gerald 1x2 组织镊, 弯头
18 cm **TPG4**



Kramer-Nevins 1x2 组织镊, 弯头
12.5 cm **TPKN**



显微 Adson 1x2 组织镊
12 cm **TPMSA**



Russian 组织镊
15 cm **TPR6**

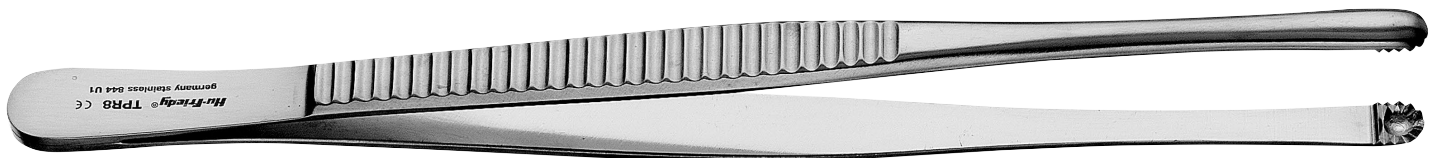

Russian 组织镊
20 cm **TPR8**

Corn 缝合镊

用于组织再生手术的理想工具

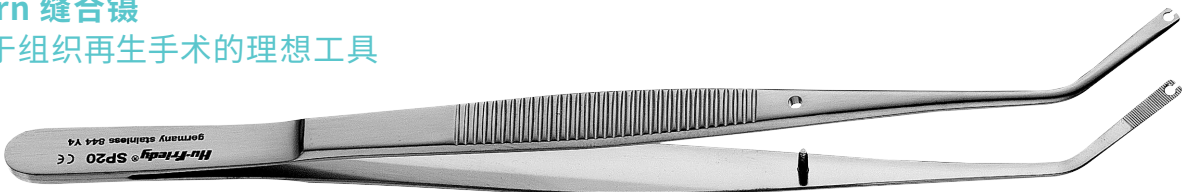

20 Corn 缝合镊
15 cm **SP20**



Corn 显微缝合镊, 金刚砂涂层
18 cm **SP20SLEM**



显微组织镊

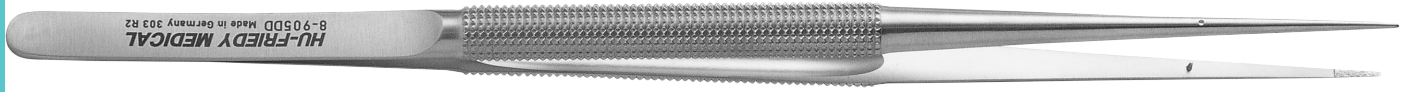

显微组织镊, 直头工作尖含金刚砂涂层

18 cm

8-905DD

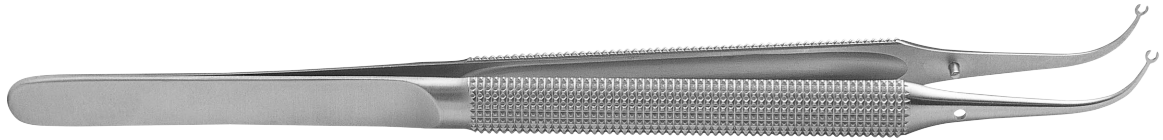

显微缝合镊

15 cm

SPM20



Swiss Perio 显微组织镊

18 cm

SPTDPAPV



Swiss Perio 显微组织镊, 直头有齿

18 cm

SPTDSSPV



显微组织镊 (钛) 直头

18 cm

TPASTMBH



显微组织镊, 工作尖含金刚砂涂层

18 cm

TPDAPV



1x2 显微组织镊

18 cm

TPDSCPV



显微组织镊, 直头

18 cm

TPDSSPV



Schlee 显微组织镊, 直头

18 cm

TPSLASCHLE



Cooley 显微组织镊, 弯头

18 cm

TPSLCOCMN



Cooley 显微组织镊, 直头多齿

18 cm

TPSLCOSM



Schlee 显微组织镊, 直头

18 cm

TPSLSSCHLE



1x2 组织镊, 直头 (钛)

18 cm

TPSSTMBH



Perma Sharp™ 组织镊



Adson Perma Sharp™ 组织镊
12 cm **TP5041**



Adson 1x2 Perma Sharp™ 组织镊
12 cm **TP5042**

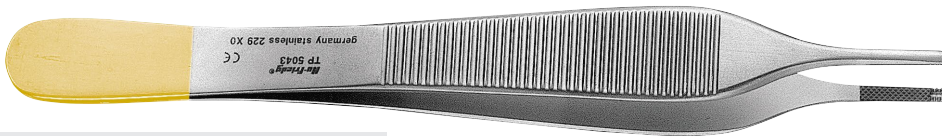

Adson-Brown Perma Sharp™ 组织镊
12 cm **TP5043**

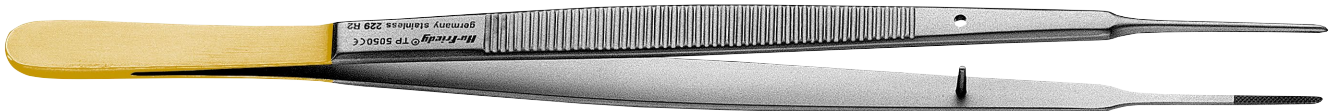

Gerald Perma Sharp™ 组织镊
18 cm **TP5050**

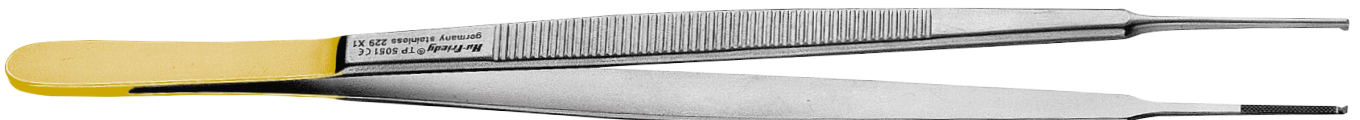

Gerald 1x2 Perma Sharp™ 组织镊
18 cm **TP5051**



Cushing Perma Sharp™ 组织镊
18 cm **TP5060**



Cushing Perma Sharp™ 组织镊, 弯头
18 cm **TP5061**

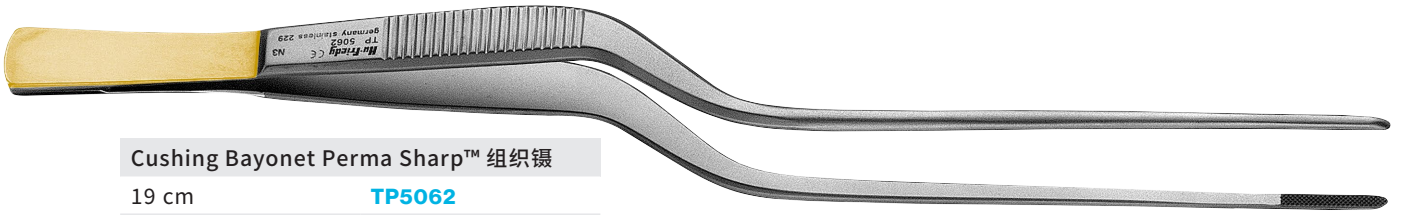

Cushing Bayonet Perma Sharp™ 组织镊
19 cm TP5062

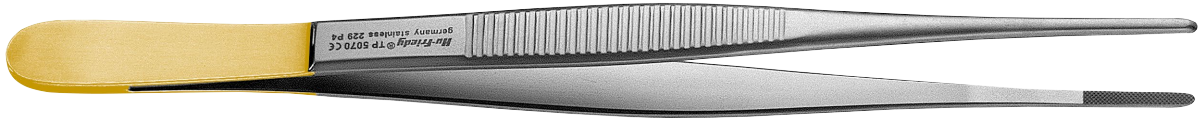

General Perma Sharp™ 组织镊
15 cm TP5070

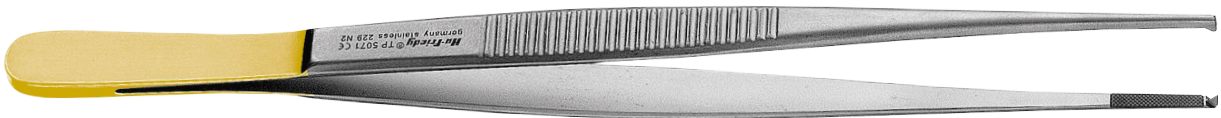

General 1x2 Perma Sharp™ 组织镊
15 cm TP5071

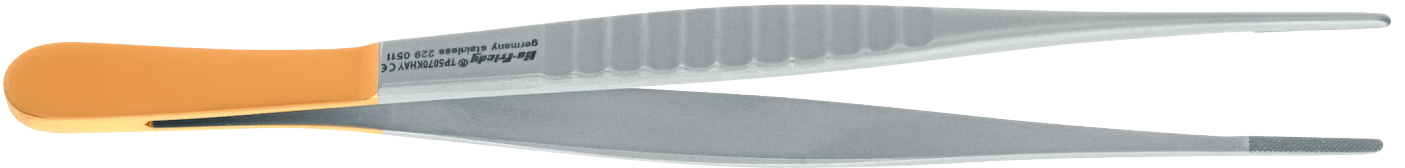

Perma Sharp™ 组织镊
15 cm TP5072

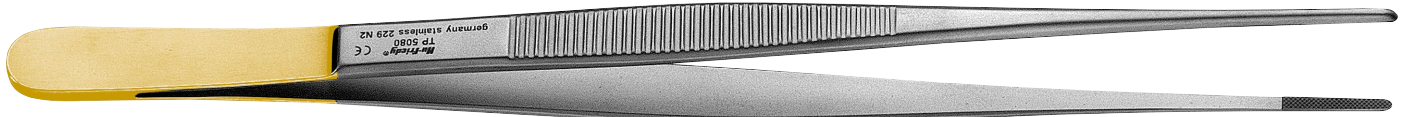

Potts-Smith Perma Sharp™ 组织镊
18 cm TP5080

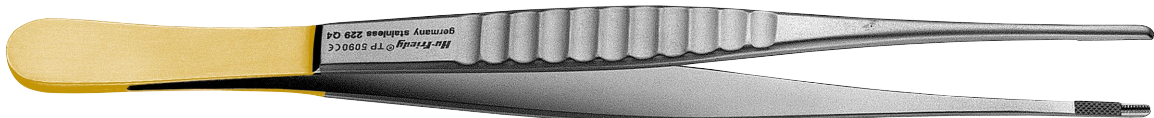

DeBakey Perma Sharp™ 组织镊
15 cm TP5090



DeBakey Perma Sharp™ 组织镊
19 cm TP5091



组织钳



Allison Baby 组织钳

13 cm

TFB



Allison 组织钳

15 cm, 45°

TF45

15 cm, 直头

TFS

组织钳

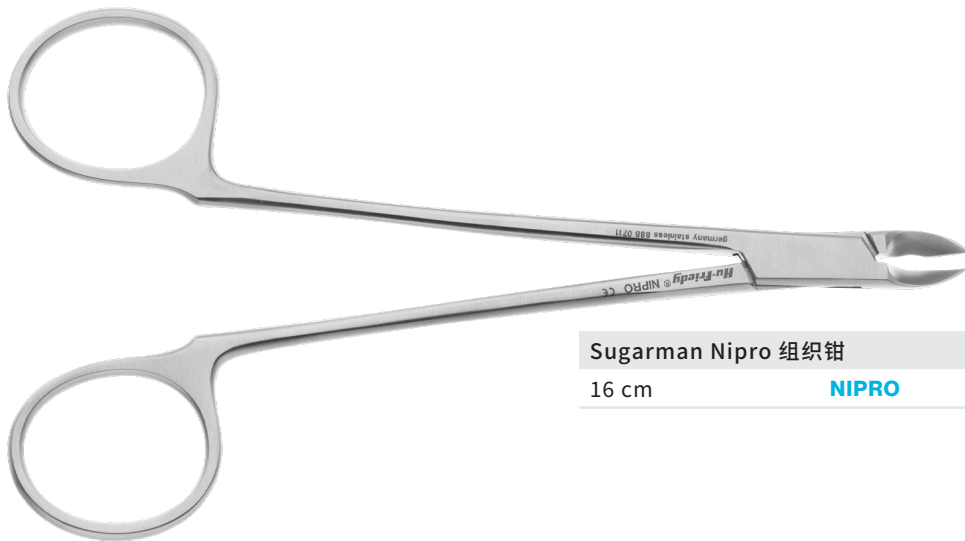

Sugarman Nipro 组织钳

16 cm

NIPRO



G/F 小组织钳

10 cm

NIPS



本图册以及本图册收录的内容,包括但不限于所有文字、数据、图片、图表、版面设计、排版方式、标识的所有权、著作权等知识产权以及其他权利均为 Hu-Friedy Mfg. Co., LLC及其附属公司或关联公司专属所有。未经事先书面许可,不得擅自使用,包括但不限于以任何形式使用、复制、转让、发行、传播、转载、出版、修改、改编或曲解本图册收录的内容。

除非另有说明,否则所有标识均在 Hu-Friedy Mfg. Co., LLC及其附属公司或关联公司的商标权的范围内,包括公司名称、产品名称、文字/图形及其组合、品牌名称、标识等。未经事先书面许可,不得使用本图册中任何商标的全部或部分。

豪孚迪医疗器械(上海)有限公司

地址:上海市浦东新区康桥东路1365弄29号 客服电话:021-68183182*843

邮箱: customer_service_china@hu-friedy.com

中文网站: <https://www.hufriedygroup.com/china/zh-hans>



器械再处理与灭菌

感染防控是每一个成功的牙科诊疗机构的基石。虽然感染性病原体和感染性疾病在口腔诊疗环境中的传播很少见，但确实会发生，这就是为什么不断强调最佳实践和行业标准的重要性至关重要的原因。豪孚迪公司具有一系列的解决方案，以助您建立安全、合规和高效的文化。

器械管理

B101

器械再处理

B201

器械盒与附件	B102
Infinity™ 无限系列器械盒	B102
Signature™ 标志系列器械盒	B108
附件及整理用品	B112
器械盒替换部件	B115

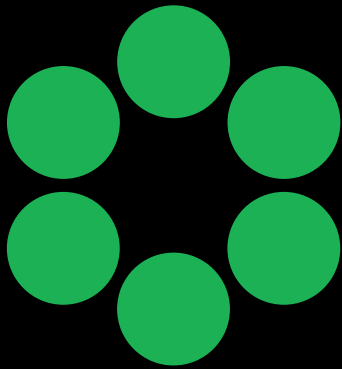

器械管理

我们的器械管理系统(IMS)以器械盒为基础,可减少器械转运及清洗过程中对污染器械的接触,从而可高效、安全地对器械进行处理。IMS通过去除器械处理过程中耗时且具有潜在风险的步骤,可使每项诊疗节约5-10分钟时间,降低锐器伤风险,保护器械、提高效率从而增加盈利。同时,IMS可提高对感染防控标准的依从性。



器械盒与附件

IMS™ 器械盒采用高品质、电抛光不锈钢制成，防腐蚀，外观专业。盒内硅胶条为医用级别，经久耐用。锁扣坚固、符合人体工程学，采用主动锁定机制。IMS™ 器械盒有多种尺寸、配置和颜色，为您提供 100 多种选择，以最大程度地满足您的需求。

Infinity™ 无限系列器械盒

Infinity™ 无限系列器械盒孔洞及硅胶条设计具有创新性，可在器械再处理过程中允许更多水流通过、与现今使用的机械清洗设备兼容性更高。边角光滑圆钝，便于排水和干燥，盒的斜边则更符合人体工程学。有 11 种颜色。

诊断器械盒



5支装诊断器械盒

可容纳5支器械

3" x 8" x 1.25" (76 mm x 203 mm x 32 mm)

● 红色	IMN6050
● 灰色	IMN6051
○ 白色	IMN6052
● 橙色	IMN6053
● 紫色	IMN6054
● 黄色	IMN6055
● 紫罗兰色	IMN6056
● 黑色	IMN6057
● 蓝色	IMN6058
● 绿色	IMN6059
● 海洋蓝色	IMN60511



小器械盒



8支装小器械盒

可容纳8支器械, 有附件区。

5.5" x 8" x 1.25" (140 mm x 203 mm x 32 mm)

● 红色	IMN5080
● 灰色	IMN5081
○ 白色	IMN5082
● 橙色	IMN5083
● 紫色	IMN5084
● 黄色	IMN5085
● 紫罗兰色	IMN5086
● 黑色	IMN5087
● 蓝色	IMN5088
● 绿色	IMN5089
● 海洋蓝色	IMN50811



10支装小器械盒

可容纳10支器械, 无附件区。

5.5" x 8" x 1.25" (140 mm x 203 mm x 32 mm)

● 红色	IMN5100
● 灰色	IMN5101
○ 白色	IMN5102
● 橙色	IMN5103
● 紫色	IMN5104
● 黄色	IMN5105
● 紫罗兰色	IMN5106
● 黑色	IMN5107
● 蓝色	IMN5108
● 绿色	IMN5109
● 海洋蓝色	IMN51011

12支装 Signa-Stat 器械盒

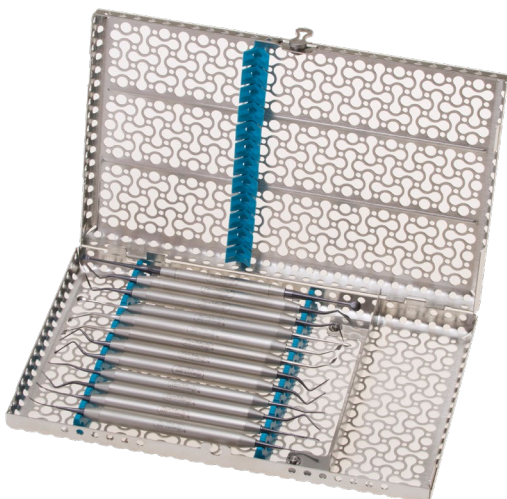

12支装 Signa-Stat 器械盒

可容纳12支器械, 有附件区。与SCiCan® STATIM®或Midmark M3 灭菌器匹配。

6.5" x 10.5" x 1.25" (165 mm x 267 mm x 32 mm)

● 红色	IMN8120
● 灰色	IMN8121
○ 白色	IMN8122
● 橙色	IMN8123
● 紫色	IMN8124
● 黄色	IMN8125
● 紫罗兰色	IMN8126
● 黑色	IMN8127
● 蓝色	IMN8128
● 绿色	IMN8129
● 海洋蓝色	IMN81211



大器械盒



12/16支装大器械盒，有附件区
可容纳12/16支器械，有大的附件区。
8" x 11" x 1.25" (203 mm x 280 mm x 32 mm)

	12支装	16支装
● 红色	IMN4120	IMN4160
● 灰色	IMN4121	IMN4161
○ 白色	IMN4122	IMN4162
● 橙色	IMN4123	IMN4163
● 紫色	IMN4124	IMN4164
● 黄色	IMN4125	IMN4165
● 紫罗兰色	IMN4126	IMN4166
● 黑色	IMN4127	IMN4167
● 蓝色	IMN4128	IMN4168
● 绿色	IMN4129	IMN4169
● 海洋蓝色	IMN41211	IMN41611



20支装大器械盒
可容纳20支器械，无附件区。
8" x 11" x 1.25" (203 mm x 280 mm x 32 mm)

● 红色	IMN4200
● 灰色	IMN4201
○ 白色	IMN4202
● 橙色	IMN4203
● 紫色	IMN4204
● 黄色	IMN4205
● 紫罗兰色	IMN4206
● 黑色	IMN4207
● 蓝色	IMN4208
● 绿色	IMN4209
● 海洋蓝色	IMN42011



Double-Decker™ (双层) 器械盒



8支装 Double-Decker™ (双层) 器械盒

双层器械盒，每层可容纳4支器械，共容纳8支器械。
3" x 8" x 1.5" (76 mm x 203 mm x 38 mm)

● 红色	IMN9080
● 灰色	IMN9081
○ 白色	IMN9082
● 橙色	IMN9083
● 紫色	IMN9084
● 黄色	IMN9085
● 紫罗兰色	IMN9086
● 黑色	IMN9087
● 蓝色	IMN9088
● 绿色	IMN9089
● 海洋蓝色	IMN90811

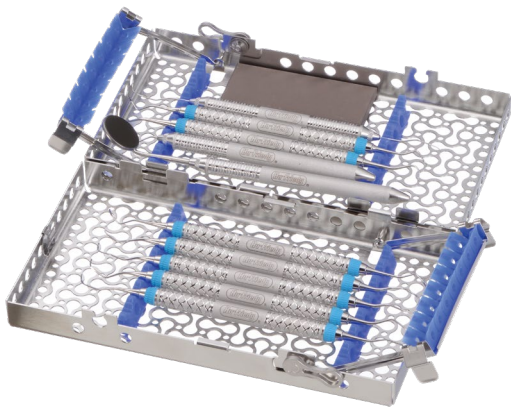

14支装 Double-Decker™ (双层) 器械盒

双层器械盒，每层可容纳7支器械，共容纳14支器械。
4.5" x 8" x 1.5" (114 mm x 203 mm x 38 mm)

● 红色	IMN9140
● 灰色	IMN9141
○ 白色	IMN9142
● 橙色	IMN9143
● 紫色	IMN9144
● 黄色	IMN9145
● 紫罗兰色	IMN9146
● 黑色	IMN9147
● 蓝色	IMN9148
● 绿色	IMN9149
● 海洋蓝色	IMN91411

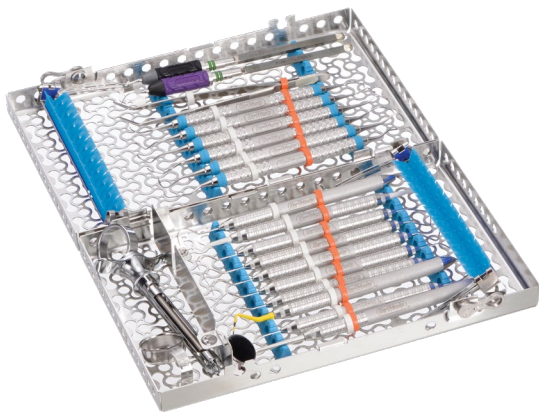

20支装 Double-Decker™ (双层) 器械盒

双层器械盒，每层可容纳10支器械，共容纳20支器械。有附件区，内置针帽架，并有容纳翼状注射器的卡口。
6" x 9.7" x 1.5" (152 mm x 246 mm x 38 mm)

● 红色	IMN9200
● 灰色	IMN9201
○ 白色	IMN9202
● 橙色	IMN9203
● 紫色	IMN9204
● 黄色	IMN9205
● 紫罗兰色	IMN9206
● 黑色	IMN9207
● 蓝色	IMN9208
● 绿色	IMN9209
● 海洋蓝色	IMN92011



口腔外科器械盒



口腔外科器械盒

可容纳12支器械，4支牙挺，盒盖上可容纳3支铰链器械，有大的附件区。铰链器械应打开关节。可放入内腔10"以上的灭菌器、绝大多数清洗消毒机以及大的超声清洗机内处理。
8" x 14.5" x 1.25" (203 mm x 368 mm x 32 mm)

● 红色	IMN0S0
● 灰色	IMN0S1
○ 白色	IMN0S2
● 橙色	IMN0S3
● 紫色	IMN0S4
● 黄色	IMN0S5
● 紫罗兰色	IMN0S6
● 黑色	IMN0S7
● 蓝色	IMN0S8
● 绿色	IMN0S9
● 海洋蓝色	IMN0S11

超声工作尖/手机器械盒

小号超声工作尖/手机器械盒可容纳2个超声工作尖或1支手机。大号超声工作尖/手机器械盒可容纳5个超声工作尖或3支手机。两种器械盒具有硅胶垫以保护精密器械。

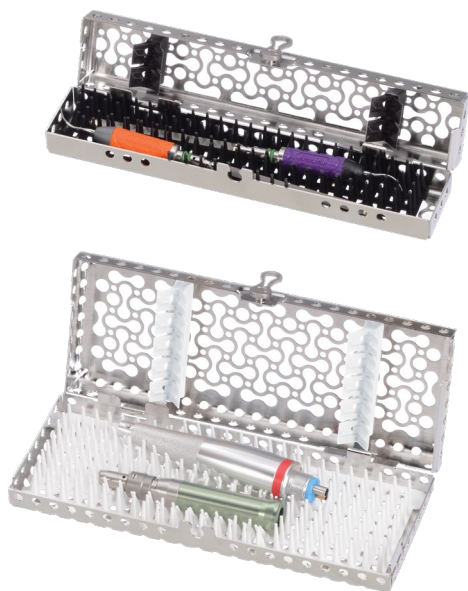

超声工作尖/手机器械盒

	小号 1.5" x 8" x 1.25" (38 mm x 203 mm x 32 mm)	大号 3" x 8" x 1.25" (76 mm x 203 mm x 32 mm)
● 红色	IMN30HU0	IMN60H0
● 灰色	IMN30HU1	IMN60H1
○ 白色	IMN30HU2	IMN60H2
● 橙色	IMN30HU3	IMN60H3
● 紫色	IMN30HU4	IMN60H4
● 黄色	IMN30HU5	IMN60H5
● 紫罗兰色	IMN30HU6	IMN60H6
● 黑色	IMN30HU7	IMN60H7
● 蓝色	IMN30HU8	IMN60H8
● 绿色	IMN30HU9	IMN60H9
● 海洋蓝色	IMN30HU11	IMN60H11



正畸器械盒

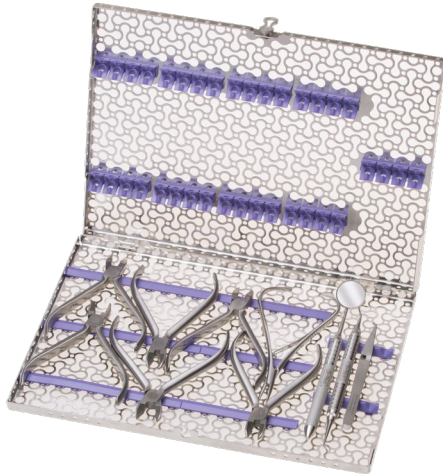

大号正畸器械盒

可容纳7把正畸钳、4支器械。铰链器械应打开关节。
8" x 11" x .75" (203 mm x 280 mm x 19 mm)

● 紫色	IMNORTHL4
● 蓝色	IMNORTHL8
● 绿色	IMNORTHL9



小号正畸器械盒

可容纳4把正畸钳、3支器械。铰链器械应打开关节。
7" x 8" x .75" (178 mm x 203 mm x 19 mm)

● 紫色	IMNORTHS4
● 蓝色	IMNORTHS8
● 绿色	IMNORTHS9

小号 Double-Decker™ (双层) 正畸器械盒



小号 Double-Decker™ (双层) 正畸器械盒

可容纳3把正畸钳、一把Mathieu持针器、2支器械。铰链器械应打开关节。

4.5" x 8" x 1.5" (114 mm x 203 mm x 38 mm)

● 红色	IMN9140-O
● 灰色	IMN9141-O
○ 白色	IMN9142-O
● 橙色	IMN9143-O
● 紫色	IMN9144-O
● 黄色	IMN9145-O
● 紫罗兰色	IMN9146-O
● 黑色	IMN9147-O
● 蓝色	IMN9148-O
● 绿色	IMN9149-O
● 海洋蓝色	IMN91411-O



Signature™ 标志系列器械盒

Signature™ 标志系列器械盒采用高品质、电抛光不锈钢制成，盒内硅胶条为医用级别、经久耐用。锁扣坚固、主动锁定，有8种颜色。

诊断器械盒

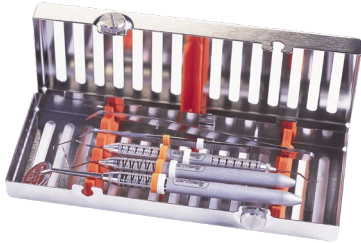

诊断器械盒

可容纳5支器械

3" x 8" x 1.25" (76 mm x 203 mm x 32 mm)

● 红色	IM6050
● 灰色	IM6051
○ 白色	IM6052
● 橙色	IM6053
● 黄色	IM6055
● 紫罗兰色	IM6056
● 蓝色	IM6058
● 绿色	IM6059

小器械盒

8支装小器械盒有附件区，10支装小器械盒无附件区。



小器械盒

8支装

5.5" x 8" x 1.25"
(140 mm x 203 mm
x 32 mm)

10支装

5.5" x 8" x 1.25"
(140 mm x 203 mm
x 32 mm)

● 红色	IM5080	IM5100
● 灰色	IM5081	IM5101
○ 白色	IM5082	IM5102
● 橙色	IM5083	IM5103
● 黄色	IM5085	IM5105
● 紫罗兰色	IM5086	IM5106
● 蓝色	IM5088	IM5108
● 绿色	IM5089	IM5109

12支装 Signa-Stat 器械盒



12支装 Signa-Stat 器械盒

可容纳12支器械，有附件区。与SciCan® STATIM® 或 Midmark M3 灭菌器匹配。

6.5" x 10.5" x 1.25" (165 mm x 267 mm x 32 mm)

● 红色	IM8120
● 灰色	IM8121
○ 白色	IM8122
● 橙色	IM8123
● 黄色	IM8125
● 紫罗兰色	IM8126
● 蓝色	IM8128
● 绿色	IM8129



大器械盒

12支装和16支装大器械盒有一个大的附件区，20支装大器械盒无附件区。



大器械盒

8" x 11" x 1.25" (203 mm x 280 mm x 32 mm)

	12支装	16支装	20支装
● 红色	IM4120	IM4160	IM4200
● 灰色	IM4121	IM4161	IM4201
○ 白色	IM4122	IM4162	IM4202
● 橙色	IM4123	IM4163	IM4203
● 黄色	IM4125	IM4165	IM4205
● 紫罗兰色	IM4126	IM4166	IM4206
● 蓝色	IM4128	IM4168	IM4208
● 绿色	IM4129	IM4169	IM4209

8支装 Double-Decker™ (双层) 器械盒

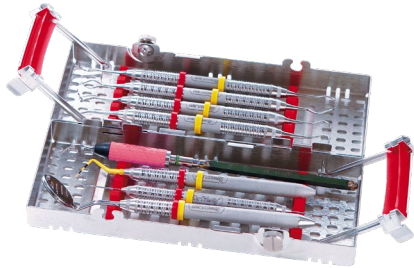

8支装 Double-Decker™ (双层) 器械盒

双层器械盒，每层可容纳4支器械，共容纳8支器械。
3" x 8" x 1.5" (76 mm x 203 mm x 38 mm)

● 红色	IM9080
● 灰色	IM9081
○ 白色	IM9082
● 橙色	IM9083
● 黄色	IM9085
● 紫罗兰色	IM9086
● 蓝色	IM9088
● 绿色	IM9089

14支装 Double-Decker™ (双层) 器械盒



14支装 Double-Decker™ (双层) 器械盒

双层器械盒，每层可容纳7支器械，共容纳14支器械。
4.5" x 8" x 1.5" (114 mm x 203 mm x 38 mm)

● 红色	IM9140
● 灰色	IM9141
○ 白色	IM9142
● 橙色	IM9143
● 黄色	IM9145
● 紫罗兰色	IM9146
● 蓝色	IM9148
● 绿色	IM9149



20支装 Double-Decker™ (双层) 器械盒

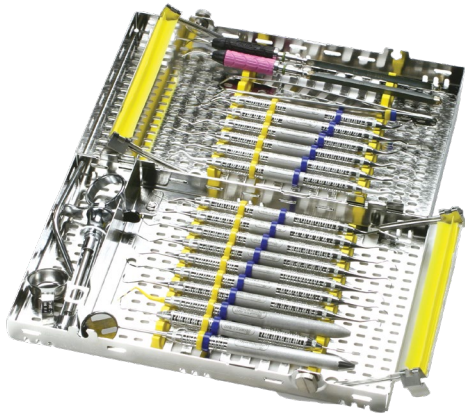

20支装 Double-Decker™ (双层) 器械盒
 双层器械盒，每层可容纳10支器械，共容纳20支器械。
 6" x 9.7" x 1.5" (152 mm x 246 mm x 38 mm)

● 红色	IM9200
● 灰色	IM9201
○ 白色	IM9202
● 橙色	IM9203
● 黄色	IM9205
● 紫罗兰色	IM9206
● 蓝色	IM9208
● 绿色	IM9209

口腔外科器械盒



口腔外科器械盒
 可容纳12支器械，4支牙挺，盒盖上可容纳3支铰链器械，有大的附件区。铰链器械应打开关节。可放入内腔10" 以上的灭菌器、绝大多数清洗消毒机以及大的超声清洗机内处理。
 8" x 14.5" x 1.25" (203 mm x 368 mm x 32 mm)

● 红色	IMOS0
● 灰色	IMOS1
○ 白色	IMOS2
● 橙色	IMOS3
● 黄色	IMOS5
● 紫罗兰色	IMOS6
● 蓝色	IMOS8
● 绿色	IMOS9

超声工作尖/手机器械盒

小号超声工作尖/手机器械盒可容纳2个超声工作尖或1支手机。大号超声工作尖/手机器械盒可容纳5个超声工作尖或3支手机。两种器械盒具有硅胶垫以保护精密器械。



超声工作尖/手机器械盒

	小号 1.5" x 8" x 1.25" (38 mm x 203 mm x 32 mm)	大号 3" x 8" x 1.25" (76 mm x 203 mm x 32 mm)
--	--	--

● 红色	IM30HU0	IM60H0
● 灰色	IM30HU1	IM60H1
○ 白色	IM30HU2	IM60H2
● 橙色	IM30HU3	IM60H3
● 黄色	IM30HU5	IM60H5
● 紫罗兰色	IM30HU6	IM60H6
● 蓝色	IM30HU8	IM60H8
● 绿色	IM30HU9	IM60H9



正畸器械盒



大号正畸器械盒

可容纳7把正畸钳、4支器械。铰链器械应打开关节。
8" x 11" x .75" (203 mm x 280 mm x 19 mm)

● 蓝色

IMORTHLG8

小号正畸器械盒

可容纳4把正畸钳、3支器械。铰链器械应打开关节。
7" x 8" x .75" (178 mm x 203 mm x 19 mm)

● 蓝色

IMORTHSM8

小号 Double-Decker™ (双层) 正畸器械盒



小号 Double-Decker™ (双层) 正畸器械盒

可容纳3把正畸钳、一把Mathieu持针器、2支器械。
铰链器械应打开关节。

4.5" x 8" x 1.5" (114 mm x 203 mm x 38 mm)

● 红色

IM9140-OR

● 灰色

IM9141-OR

○ 白色

IM9142-OR

● 橙色

IM9143-OR

● 黄色

IM9145-OR

● 紫罗兰色

IM9146-OR

● 蓝色

IM9148-OR

● 绿色

IM9149-OR

大号 Double-Decker™ (双层) 正畸器械盒



大号 Double-Decker™ (双层) 正畸器械盒

可容纳6把正畸钳、一把Mathieu持针器、3支器械。铰链器械应打开关节。

6" x 8" x 1.5" (152 mm x 203 mm x 38 mm)

● 红色

IM5200-OR

● 灰色

IM5201-OR

○ 白色

IM5202-OR

● 橙色

IM5203-OR

● 黄色

IM5205-OR

● 紫罗兰色

IM5206-OR

● 蓝色

IM5208-OR

● 绿色

IM5209-OR



附件及整理用品

我们有多种器械盒附件以及整理用品，以满足盛放小物品、颜色标识以及追溯需求。

小零件盒

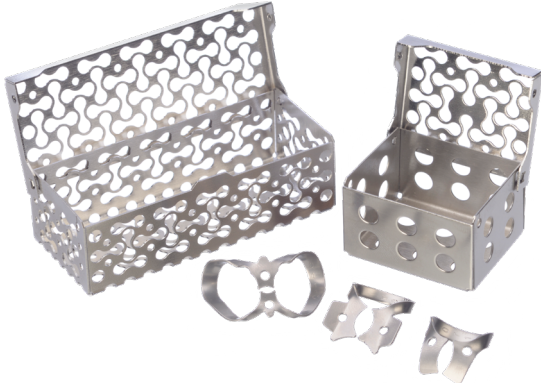

IMS™ 小零件盒

用于放置小的物品，如口镜头、橡皮障夹等，以保证其在清洗灭菌过程中规整有序。

大号
3.5" x 1.12" x 1" (89 mm x 29 mm x 25 mm)

IMS-1273

小号
1.56" x 1.25" x 1" (40 mm x 32 mm x 25 mm)

IMS-1271

器械盒标识牌



标志系列器械盒标识牌

.88" x 1.88" x .047"
(22 mm x 48 mm x 1.2 mm)

IMS-1378



无限系列器械盒标识牌

.88" x 1.75" x .047"
(22 mm x 44 mm x 1.2 mm)

IMS-1379

扩孔钻/锉架

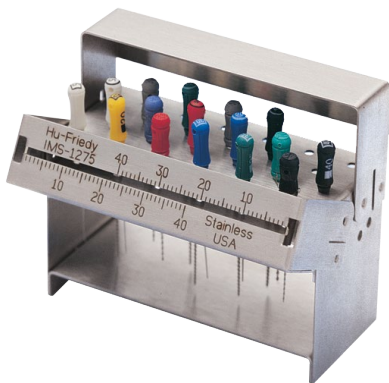

扩孔钻/锉架

放置扩孔钻、扩孔锉等。双盖合叶架，盖子双侧均有标尺，用于测量扩孔的深度。

2.6" x 2.25" x 1.2" (67 mm x 57 mm x 30 mm)

24支装

IMS-1275

48支装

IMS-1275D

三用枪头夹

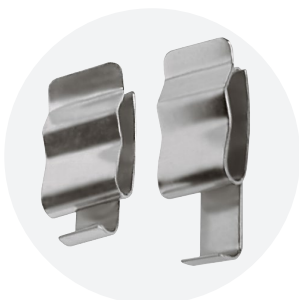

三用枪头夹

将三用枪头牢固地固定于器械盒上，夹子可直接卡在器械盒上。

Infinity™ 无限系列器械盒用

IM1005N

Signature™ 标志系列器械盒用

IM1005

无限系列与标志系列双层器械盒用

IM1006



车针架

IMS™ 车针架为中空、长方形、硅胶底座，盖子为不锈钢，用于在清洗灭菌过程中将车针牢固固定于架子上。中空的设计利于清洗过程中清洗和干燥，硅胶底座适用于不同大小的车针。



低盖型 IMS™ 1/2 车针架

1.75" x 1.3" x .9"
(44 mm x 33 mm x 22 mm)

IMS-1372SH

高盖型 IMS™ 1/2 车针架

1.75" x 2.44" x .9"
(44 mm x 62 mm x 22 mm)

IMS-1372TH

低盖型 IMS™ 车针架

3.3" x 1.3" x .9"
(984 mm x 33 mm x 22 mm)

IMS-1372S

高盖型 IMS™ 车针架

3.3" x 2.44" x .9"
(84 mm x 62 mm x 22 mm)

IMS-1372T

铰链器械夹



铰链器械夹

将剪刀、血管钳等铰链器械呈关节打开状态固定在器械盒盖子上，以保证铰链器械的清洗和灭菌效果。

2个/包

IM1000

6个/包

IM1002

针帽固定架



针帽固定架

针帽固定架使针帽保持直立位，利于单手回套针帽。

2个/包

IM1001

6个/包

IM1003

组合装

IM1004

橡皮障夹固定板

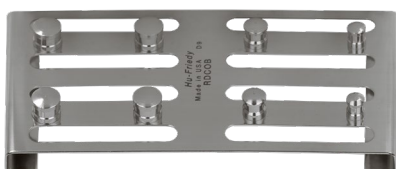

橡皮障夹固定板

可以容纳8个橡皮障夹，可放置在大部分器械盒的附件区。

4.6" x 2.4" x .375"
(117 mm x 61 mm x 10 mm)

RDCOB

**IMS™ 器械颜色识别圈-小号**

硅胶材质，用于识别和规整器械。有助于将器械在器械盒中放置在恰当位置，区分不同诊疗操作或医生。小号器械圈用于2、4号手柄。

数量：50个

● 灰色	IMS-1281
○ 白色	IMS-1282
● 橙色	IMS-1283
● 棕色	IMS-1284
● 黄色	IMS-1285
● 红色	IMS-1286
● 绿色	IMS-1287
● 蓝色	IMS-1288
● 黑色	IMS-1289
● 粉色	IMS-12810
● 紫罗兰色	IMS-12811
● 海洋蓝色	IMS-12812
● 紫色	IMS-12813

混色 - 数量：90个 [IMS-1280](#)

**IMS™ 器械颜色识别圈-大号**

硅胶材质，用于识别和规整器械。有助于将器械在器械盒中放置在恰当位置，区分不同诊疗操作或医生。大号器械圈用于6、7、8、9号手柄。

数量：50个

● 灰色	IMS-1281L
○ 白色	IMS-1282L
● 橙色	IMS-1283L
● 棕色	IMS-1284L
● 黄色	IMS-1285L
● 红色	IMS-1286L
● 绿色	IMS-1287L
● 蓝色	IMS-1288L
● 黑色	IMS-1289L
● 粉色	IMS-12810L
● 紫罗兰色	IMS-12811L
● 海洋蓝色	IMS-12812L
● 紫色	IMS-12813L

混色 - 数量：90个 [IMS-1280L](#)

颜色识别块

硅胶材质的色块，用于器械盒盖子上，区分医生或诊疗操作。

数量：5个

混色	IMS-1290N
● 灰色	IMS-1291N
○ 白色	IMS-1292N
● 橙色	IMS-1293N
● 棕色	IMS-1294N
● 黄色	IMS-1295N
● 红色	IMS-1296N
● 绿色	IMS-1297N
● 蓝色	IMS-1298N
● 黑色	IMS-1299N
● 粉色	IMS-12910N
● 紫罗兰色	IMS-12911N
● 紫色	IMS-12913N

混色 - 数量：13 [IMS-12912N](#)



器械盒替换部件

长时间使用之后,有时硅胶条或者器械盒上的其他小部件需要替换,我们有各种替换用的部件,以保持您的器械盒弥久长新。

Infinity™ 无限系列硅胶条替换装

为保持一致性,同一器械盒内的硅胶条最好同时更换。要确定需要哪种替换装,请查看 Infinity™ 无限系列器械盒盖子。如果您的盖子图案上有两条浮雕条纹,则需要订购用于浮雕盖的替换装。

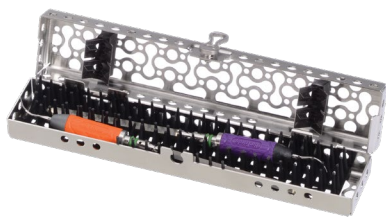

Infinity™ 无限系列小手机械盒硅胶条替换装

● 红色	PK-30HU0RL
● 灰色	PK-30HU1RL
○ 白色	PK-30HU2RL
● 橙色	PK-30HU3RL
● 紫色	PK-30HU4RL
● 黄色	PK-30HU5RL
● 紫罗兰色	PK-30HU6RL
● 黑色	PK-30HU7RL
● 蓝色	PK-30HU8RL
● 绿色	PK-30HU9RL
● 海洋蓝色	PK-30HU11R



平盖



浮雕盖

Infinity™ 无限系列12支装大器械盒硅胶条替换装

	普通	浮雕盖
● 红色	PK-4120RL	PKE-4120R
● 灰色	PK-4121RL	PKE-4121R
○ 白色	PK-4122RL	PKE-4122R
● 橙色	PK-4123RL	PKE-4123R
● 紫色	PK-4124RL	PKE-4124R
● 黄色	PK-4125RL	PKE-4125R
● 紫罗兰色	PK-4126RL	PKE-4126R
● 黑色	PK-4127RL	PKE-4127R
● 蓝色	PK-4128RL	PKE-4128R
● 绿色	PK-4129RL	PKE-4129R
● 海洋蓝色	PK-41211RL	PKE-41211R



平盖



浮雕盖

Infinity™ 无限系列16支装大器械盒硅胶条替换装

	普通	浮雕盖
● 红色	PK-4160RL	PKE-4160R
● 灰色	PK-4161RL	PKE-4161R
○ 白色	PK-4162RL	PKE-4162R
● 橙色	PK-4163RL	PKE-4163R
● 紫色	PK-4164RL	PKE-4164R
● 黄色	PK-4165RL	PKE-4165R
● 紫罗兰色	PK-4166RL	PKE-4166R
● 黑色	PK-4167RL	PKE-4167R
● 蓝色	PK-4168RL	PKE-4168R
● 绿色	PK-4169RL	PKE-4169R
● 海洋蓝色	PK-41611RL	PKE-41611R

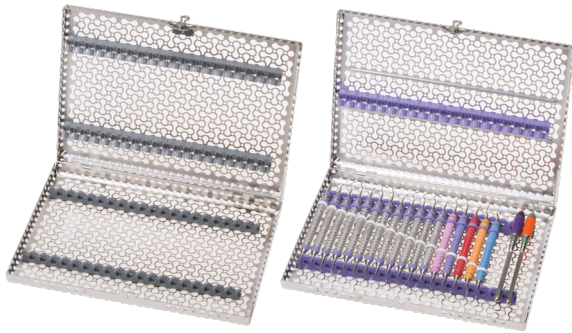

平盖

浮雕盖

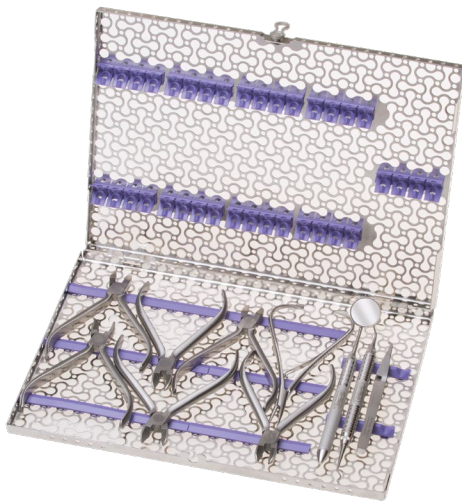

Infinity™ 无限系列20支装大器械盒硅胶条替换装

	普通	浮雕盖
● 红色	PK-4200RL	PKE-4200R
● 灰色	PK-4201RL	PKE-4201R
○ 白色	PK-4202RL	PKE-4202R
● 橙色	PK-4203RL	PKE-4203R
● 紫色	PK-4204RL	PKE-4204R
● 黄色	PK-4205RL	PKE-4205R
● 紫罗兰色	PK-4206RL	PKE-4206R
● 黑色	PK-4207RL	PKE-4207R
● 蓝色	PK-4208RL	PKE-4208R
● 绿色	PK-4209RL	PKE-4209R
● 海洋蓝色	PK-42011RL	PKE-42011R

Infinity™ 无限系列大号正畸盒硅胶条替换装

● 紫色	PK-ORTL4L
● 蓝色	PK-ORTL8L
● 绿色	PK-ORTL9L

Infinity™ 无限系列小号正畸盒硅胶条替换装

● 紫色	PK-ORTS4L
● 蓝色	PK-ORTS8L
● 绿色	PK-ORTS9L

Infinity™ 无限系列8支装小器械盒硅胶条替换装

● 红色	PK2-5080R
● 灰色	PK2-5081R
○ 白色	PK2-5082R
● 橙色	PK2-5083R
● 紫色	PK2-5084R
● 黄色	PK2-5085R
● 紫罗兰色	PK2-5086R
● 黑色	PK2-5087R
● 蓝色	PK2-5088R
● 绿色	PK2-5089R
● 海洋蓝色	PK2-50811R



Infinity™ 无限系列10支装小器械盒硅胶条替换装

● 红色	PK2-5100RL
● 灰色	PK2-5101RL
○ 白色	PK2-5102RL
● 橙色	PK2-5103RL
● 紫色	PK2-5104RL
● 黄色	PK2-5105RL
● 紫罗兰色	PK2-5106RL
● 黑色	PK2-5107RL
● 蓝色	PK2-5108RL
● 绿色	PK2-5109RL
● 海洋蓝色	PK2-51011R



Infinity™ 无限系列5支装诊断器械盒硅胶条替换装

● 红色	PK2-6050RL
● 灰色	PK2-6051RL
○ 白色	PK2-6052RL
● 橙色	PK2-6053RL
● 紫色	PK2-6054RL
● 黄色	PK2-6055RL
● 紫罗兰色	PK2-6056RL
● 黑色	PK2-6057RL
● 蓝色	PK2-6058RL
● 绿色	PK2-6059RL
● 海洋蓝色	PK2-60511R



Infinity™ 无限系列大手机械盒硅胶条替换装

● 红色	PK-60H0RL
● 灰色	PK-60H1RL
○ 白色	PK-60H2RL
● 橙色	PK-60H3RL
● 紫色	PK-60H4RL
● 黄色	PK-60H5RL
● 紫罗兰色	PK-60H6RL
● 黑色	PK-60H7RL
● 蓝色	PK-60H8RL
● 绿色	PK-60H9RL
● 海洋蓝色	PK-60H11RL



平盖



浮雕盖

Infinity™ 无限系列12支装 Signa Stat 器械盒硅胶条替换装

	普通	浮雕盖
● 红色	PK-8120RL	PKE-8120R
● 灰色	PK-8121RL	PKE-8121R
○ 白色	PK-8122RL	PKE-8122R
● 橙色	PK-8123RL	PKE-8123R
● 紫色	PK-8124RL	PKE-8124R
● 黄色	PK-8125RL	PKE-8125R
● 紫罗兰色	PK-8126RL	PKE-8126R
● 黑色	PK-8127RL	PKE-8127R
● 蓝色	PK-8128RL	PKE-8128R
● 绿色	PK-8129RL	PKE-8129R
● 海洋蓝色	PK-81211RL	PKE-81211R



Infinity™ 无限系列双层8支装器械盒硅胶条替换装

● 红色	PK-9080RL
● 灰色	PK-9081RL
○ 白色	PK-9082RL
● 橙色	PK-9083RL
● 紫色	PK-9084RL
● 黄色	PK-9085RL
● 紫罗兰色	PK-9086RL
● 黑色	PK-9087RL
● 蓝色	PK-9088RL
● 绿色	PK-9089RL
● 海洋蓝色	PK-90811RL

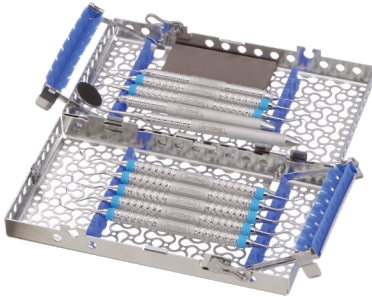

Infinity™ 无限系列双层14支装器械盒硅胶条替换装

● 红色	PK-9140RL
● 灰色	PK-9141RL
○ 白色	PK-9142RL
● 橙色	PK-9143RL
● 紫色	PK-9144RL
● 黄色	PK-9145RL
● 紫罗兰色	PK-9146RL
● 黑色	PK-9147RL
● 蓝色	PK-9148RL
● 绿色	PK-9149RL
● 海洋蓝色	PK-91411RL

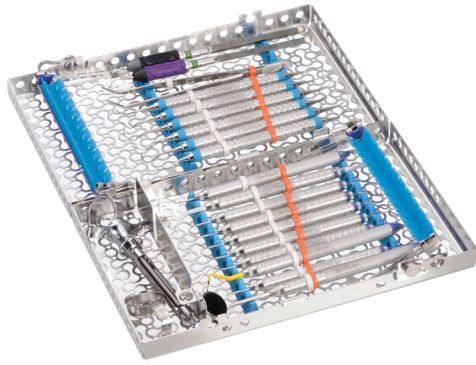

Infinity™ 无限系列双层20支装器械盒硅胶条替换装

● 红色	PK-9200RL
● 灰色	PK-9201RL
○ 白色	PK-9202RL
● 橙色	PK-9203RL
● 紫色	PK-9204RL
● 黄色	PK-9205RL
● 紫罗兰色	PK-9206RL
● 黑色	PK-9207RL
● 蓝色	PK-9208RL
● 绿色	PK-9209RL
● 海洋蓝色	PK-92011RL



平盖



浮雕盖

Infinity™ 无限系列口腔外科器械盒硅胶条替换装

	普通	浮雕盖
● 红色	PK-OS0RAIL	PKE-OS0R
● 灰色	PK-OS1RAIL	PKE-OS1R
○ 白色	PK-OS2RAIL	PKE-OS2R
● 橙色	PK-OS3RAIL	PKE-OS3R
● 紫色	PK-OS4RAIL	PKE-OS4R
● 黄色	PK-OS5RAIL	PKE-OS5R
● 紫罗兰色	PK-OS6RAIL	PKE-OS6R
● 黑色	PK-OS7RAIL	PKE-OS7R
● 蓝色	PK-OS8RAIL	PKE-OS8R
● 绿色	PK-OS9RAIL	PKE-OS9R
● 海洋蓝色	PK-OS11RAI	PKE-OS11R



Signature™ 标志系列硅胶条替换装

为保持一致性，同一器械盒内的硅胶条最好同时更换。



Signature™ 标志系列小号手机械盒硅胶条替换装

● 红色	IM30HU0RL
● 灰色	IM30HU1RL
○ 白色	IM30HU2RL
● 橙色	IM30HU3RL
● 黄色	IM30HU5RL
● 紫罗兰色	IM30HU6RL
● 蓝色	IM30HU8RL
● 绿色	IM30HU9RL



Signature™ 标志系列8支装小器械盒硅胶条替换装

● 红色	IM5080RAIL
● 灰色	IM5081RAIL
○ 白色	IM5082RAIL
● 橙色	IM5083RAIL
● 黄色	IM5085RAIL
● 紫罗兰色	IM5086RAIL
● 蓝色	IM5088RAIL
● 绿色	IM5089RAIL



Signature™ 标志系列10支装小器械盒硅胶条替换装

● 红色	IM5100RAIL
● 灰色	IM5101RAIL
○ 白色	IM5102RAIL
● 橙色	IM5103RAIL
● 黄色	IM5105RAIL
● 紫罗兰色	IM5106RAIL
● 蓝色	IM5108RAIL
● 绿色	IM5109RAIL



Signature™ 标志系列16支装大器械盒硅胶条替换装

● 红色	IM4160RAIL
● 灰色	IM4161RAIL
○ 白色	IM4162RAIL
● 橙色	IM4163RAIL
● 黄色	IM4165RAIL
● 紫罗兰色	IM4166RAIL
● 蓝色	IM4168RAIL
● 绿色	IM4169RAIL



Signature™ 标志系列20支装大器械盒硅胶条替换装

● 红色	IM4200RAIL
● 灰色	IM4201RAIL
○ 白色	IM4202RAIL
● 橙色	IM4203RAIL
● 黄色	IM4205RAIL
● 紫罗兰色	IM4206RAIL
● 蓝色	IM4208RAIL
● 绿色	IM4209RAIL



Signature™ 标志系列双层大正畸盒硅胶条替换装

● 红色	IM5200-ORR
● 灰色	IM5201-ORR
○ 白色	IM5202-ORR
● 橙色	IM5203-ORR
● 黄色	IM5205-ORR
● 紫罗兰色	IM5206-ORR
● 蓝色	IM5208-ORR
● 绿色	IM5209-ORR

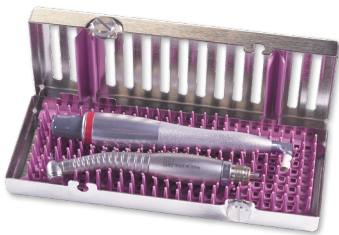

Signature™ 标志系列大手机盒硅胶条替换装

● 红色	IM60H0RAIL
● 灰色	IM60H1RAIL
○ 白色	IM60H2RAIL
● 橙色	IM60H3RAIL
● 黄色	IM60H5RAIL
● 紫罗兰色	IM60H6RAIL
● 蓝色	IM60H8RAIL
● 绿色	IM60H9RAIL

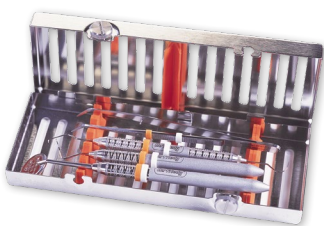

Signature™ 标志系列5支装诊断器械盒硅胶条替换装

● 红色	IM6050RAIL
● 灰色	IM6051RAIL
○ 白色	IM6052RAIL
● 橙色	IM6053RAIL
● 黄色	IM6055RAIL
● 紫罗兰色	IM6056RAIL
● 蓝色	IM6058RAIL
● 绿色	IM6059RAIL

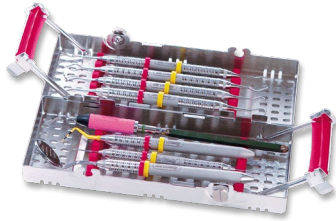

Signature™ 标志系列8支装双层器械盒硅胶条替换装

● 红色	IM9080RAIL
● 灰色	IM9081RAIL
○ 白色	IM9082RAIL
● 橙色	IM9083RAIL
● 黄色	IM9085RAIL
● 紫罗兰色	IM9086RAIL
● 蓝色	IM9088RAIL
● 绿色	IM9089RAIL



Signature™ 标志系列14支装双层器械盒硅胶条替换装

● 红色	IM9140RAIL
● 灰色	IM9141RAIL
○ 白色	IM9142RAIL
● 橙色	IM9143RAIL
● 黄色	IM9145RAIL
● 紫罗兰色	IM9146RAIL
● 蓝色	IM9148RAIL
● 绿色	IM9149RAIL

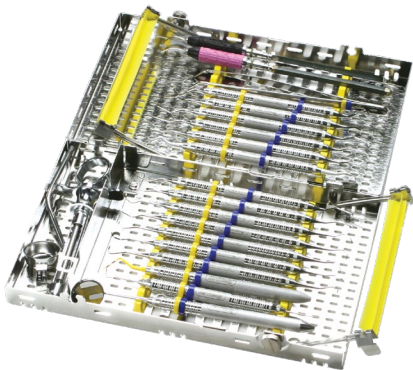

Signature™ 标志系列20支装双层器械盒硅胶条替换装

● 红色	IM9200RAIL
● 灰色	IM9201RAIL
○ 白色	IM9202RAIL
● 橙色	IM9203RAIL
● 黄色	IM9205RAIL
● 紫罗兰色	IM9206RAIL
● 蓝色	IM9208RAIL
● 绿色	IM9209RAIL



Signature™ 标志系列12支装 Signa Stat 器械盒硅胶条替换装

● 红色	IM8120RAIL
● 灰色	IM8121RAIL
○ 白色	IM8122RAIL
● 橙色	IM8123RAIL
● 黄色	IM8125RAIL
● 紫罗兰色	IM8126RAIL
● 蓝色	IM8128RAIL
● 绿色	IM8129RAIL



Signature™ 标志系列口腔外科器械盒硅胶条替换装

● 红色	IMOS0RAIL
● 灰色	IMOS1RAIL
○ 白色	IMOS2RAIL
● 橙色	IMOS3RAIL
● 黄色	IMOS5RAIL
● 紫罗兰色	IMOS6RAIL
● 蓝色	IMOS8RAIL
● 绿色	IMOS9RAIL

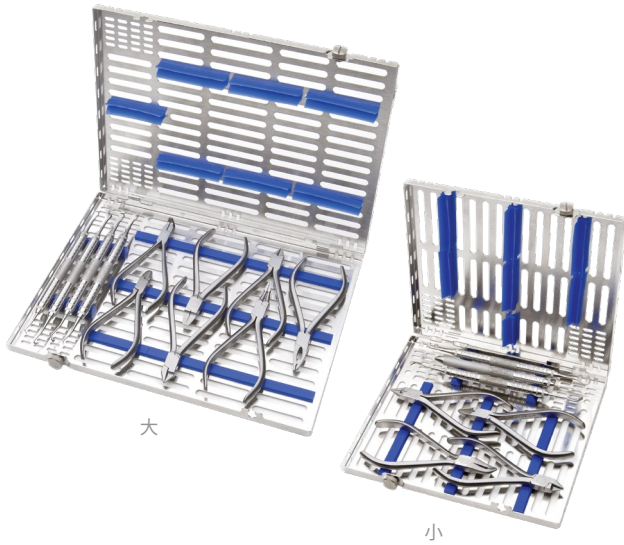

大

小

Signature™ 标志系列正畸器械盒硅胶条替换装

● 蓝色 (小)	IMORTS8RL
● 蓝色 (大)	IMORTL8RL

清洗与保养

B202

酶解决方案

B202

器械保养

B203

清洗效果监测

B203

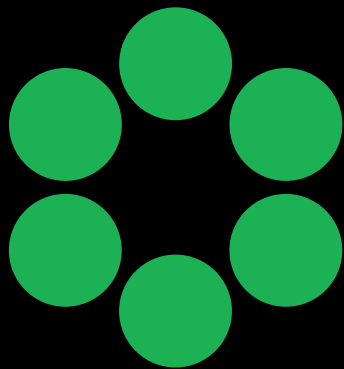

器械再处理



清洗与保养

复用性器械的正确再处理对保证患者安全、避免交叉污染至关重要，器械再处理的首要及重要环节是器械的清洗。器械清洗时使用专门的清洗剂，如酶清洗剂，以有效去除器械上的有机及无机污染物。使用清洗效果监测卡可方便地监测自动清洗消毒机以及超声清洗机的清洗效果。

酶解决方案



Enzymax™ 保湿喷雾凝胶--即用型预清洁剂
709 ml
IMS-1229



器械保养



Shine reNEW™ 除锈光亮布

有效去除污渍及锈渍，重现不锈钢器械和钨钢器械的光泽。

20张/盒

IMS-1455

清洗效果监测

清洗效果监测卡用于监测自动清洗消毒机和超声清洗机的清洗效果。



自动清洗机清洗效果监测卡

用于监测自动清洗消毒机的清洗效果。

50片/盒

IMS-1200W



超声清洗机清洗效果监测卡

用于监测超声清洗机的清洗效果。

50片/盒

IMS-1200U



清洗效果监测卡套

IMS-1200H

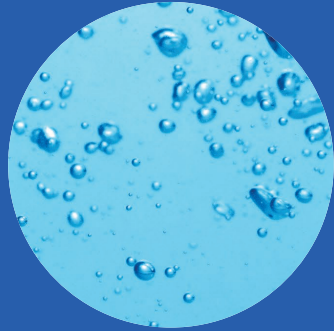
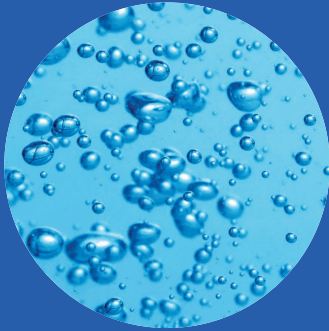
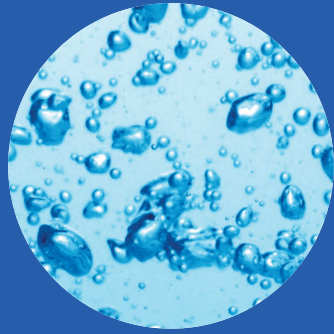
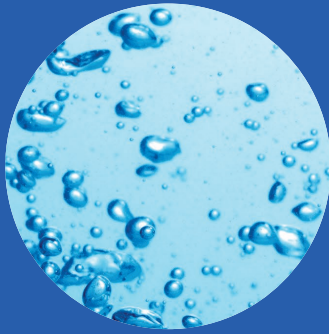
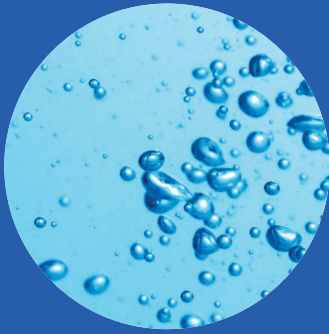
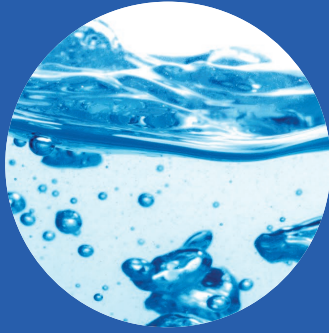

本图册以及本图册收录的内容,包括但不限于所有文字、数据、图片、图表、版面设计、排版方式、标识的所有权、著作权等知识产权以及其他权利均为 Hu-Friedy Mfg. Co., LLC及其附属公司或关联公司专属所有。未经事先书面许可,不得擅自使用,包括但不限于以任何形式使用、复制、转让、发行、传播、转载、出版、修改、改编或曲解本图册收录的内容。

除非另有说明,否则所有标识均在 Hu-Friedy Mfg. Co., LLC 及其附属公司或关联公司的商标权的范围内,包括公司名称、产品名称、文字/图形及其组合、品牌名称、标识等。未经事先书面许可,不得使用本图册中任何商标的全部或部分。

豪孚迪医疗器械(上海)有限公司

地址:上海市浦东新区康桥东路1365弄29号 客服电话:021-68183182*843

邮箱:customer_service_china@hu-friedy.com

中文网站:<https://www.hufriedygroup.com/china/zh-hans>



牙科用水管理

牙科用水水质差会对患者、员工、设备和诊所声誉造成损害。我们有全面的牙科用水相关产品，可以帮助改善患者诊疗、提高员工生产力和诊所盈利，同时有助于保证符合相关规范指南要求。

牙椅水路管理

牙椅水路 (DUWLs) 狭窄细长，为微生物生长创造了完美的温床。未经处理或维护不当时，流经这些受污染的牙椅水路并通过治疗时使用的动力器械流出的水有可能对患者、员工和诊所声誉造成损害。

持续消毒处理	C102
DentaPure™ 牙椅水路终端净化器	C102
辅助产品--碘浓度测试条	C103



持续消毒处理

持续消毒处理产品被放置在独立储水罐内或直接连接到与市政水相连的地箱内。这些产品根据使用时间或已处理的水量进行更换。

DentaPure™ 牙椅水路终端净化器

DentaPure™ 牙椅水路终端净化器可提供 365 天、或 240 升符合要求的牙科诊疗用水。它可释放非过敏性元素碘到牙椅水路中，以减少患者和工作人员的细菌暴露风险。DentaPure™ 牙椅水路终端净化器经 EPA 批准，符合 ≤ 200 CFU/mL / FDA 510k 标准。既有适用于独立储水罐、也有适用于市政供水的类型。



DentaPure™ DPC365B 牙椅水路终端净化器
DPC365B



DentaPure™ DPC365M 牙椅水路终端净化器
DPC365M



辅助产品--碘浓度测试条

适用于DentaPure™ 牙椅水路终端净化器。碘浓度测试条只能用于测定牙椅水路中碘的浓度，而不能用于测试牙椅水路中细菌的量（菌落形成单位，CFU）。建议在使用 DentaPure™ 牙椅水路终端净化器11 个月时或者使用水量接近 240 升水时测定碘浓度，以确保牙椅水路出水中的碘浓度不低于 0.5 ppm（尤其是诊疗量特别大时更要注意）。



碘浓度测试条
50条/瓶 **DPTEST**

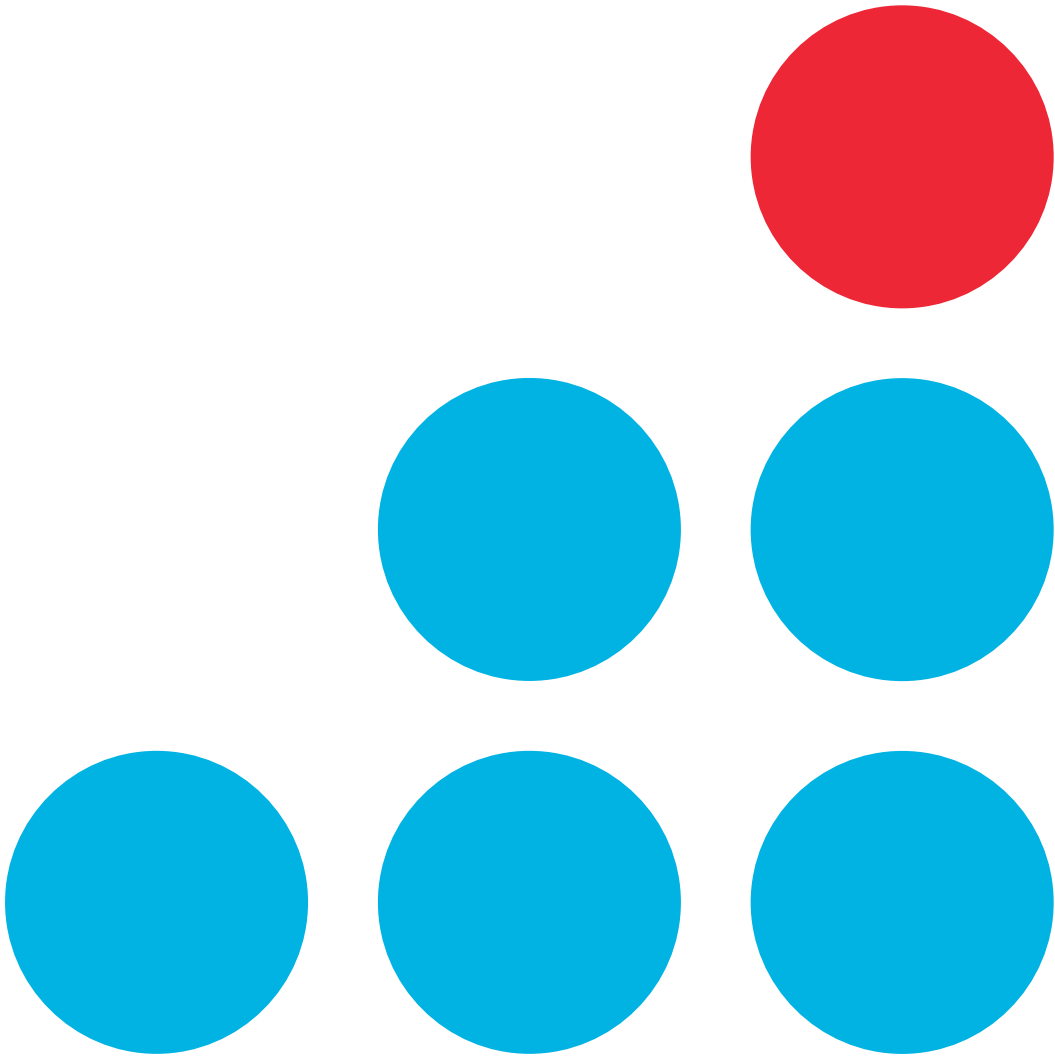



索引

#	D2	G	D5	O	D8
A	D2	H	D5	P	D8
B	D2	I	D5	R	D10
C	D2	K	D7	S	D10
D	D3	L	D7	T	D12
E	D3	M	D7	V	D12
F	D4	N	D8	X	D12

#

1-015 A885
8-905DD A898
10-100-04 A884
10-130-03 A884
10-130-05 A884
10-130-05A A884
10-130-05D A884
10-130-05E A885
10-130-5EM A885
10-130-07 A885
10-130-07K A885
10-130-08 A885
10-130-70 A509 A886
10-199-00 A886
678-001 A715
678-011 A715
678-013 A715
678-014 A715
678-014A A715
678-020 A715
678-021 A715
678-036 A715
678-101 A703
678-101L A703
678-102 A703
678-103 A703
678-104 A703
678-105 A703
678-106 A704
678-107 A704
678-107L A704
678-109 A704
678-110 A704
678-111 A703
678-200 A705
678-204 A705
678-206 A705
678-207 A705
678-208 A705
678-210 A706
678-212 A713
678-212M A713
678-219 A706
678-220L A706
678-221 A706
678-221M A706
678-225 A706
678-301 A709
678-303 A709
678-304 A709
678-305 A709
678-306 A709
678-307 A709
678-308 A709

678-309 A710
678-311 A710
678-312 A710
678-316 A710
678-317 A710
678-318 A709
678-319 A710
678-320 A710
678-321 A710
678-322 A710
678-323 A710
678-324 A710
678-325 A710
678-326 A710
678-327 A710
678-328-20 A711
678-328-21 A711
678-330 A712
678-331 A712
678-332 A712
678-340 A711
678-341 A711
678-342 A711
678-500 A704
678-501 A705
678-502 A710
678-503 A705
678-504 A713
678-505 A713
678-506 A713
678-700 A707
678-701 A707
678-702 A707
678-702-90 A707
678-703 A708
678-704 A708
678-704SER A708
678-705 A708
678-800 A702
678-801 A702
678-802 A702
678-803 A702
678-804 A702
678-805 A702
678-807 A702
678-808 A702
678-811 A702
678-904 A714
678-905 A714
678-906 A714
678-907 A714
678-909 A714
678-912 A714
678-916 A714
19100 A507
19101 A507
19102 A507

19200 A507
19201 A507
19202 A507
19300 A507
19301 A507
19302 A507
19400 A507
19401 A507
19402 A507
19500 A507
1013005D1 A884
ED46 A881

A

AKRO-FLEX A604
ALLENCARD A837
APF2 A611
ASKOT A802
ASPA A802
ASPB1 A802
ASPB2 A802
ASPB3 A802
ASPCG3 A802
ASPCH A803
ASPCT1 A803
ASPCT1W A803
ASPCT2 A803
ASPCT2W A803
ASPCT3 A803
ASPCT3W A803
ASPCT4 A803
ASPCT4W A803
ASPFR6 A803
ASPFR8 A803
ASPFR10 A803
ASPFR12 A803
ASPON A803
ASPOS1 A803
ASPOS2 A803
ASPOS3 A803
ASPOS4 A803

B

BB26/27S6 A614
BB27/296 A614
BB186 A614
BER6 A823
BER6X A823
BER7 A823
BER7X A823
BER11 A823
BER11X A823
BF1W A824

BF1W6 A824
BF1X A825
BF1X6 A825
BF2W A824
BF2W6 A824
BF2X A825
BF2X6 A825
BF3X A825
BF3X6 A825
BF12 A824
BF21 A824
BF45 A825
BF52 A825
BF64 A825
BF67 A825
BF126 A824
BF216 A824
BF456 A825
BF526 A825
BF646 A825
BF676 A825
BONT A842
BP300 A714
BPACK A842
BSJ05 A837

C

C36/376 A805
C36/379 A805
CBBC A837
CBFL112 A809
CBFL214 A809
CC1 A808
CC2 A808
CC4 A808
CC7 A808
CC8 A808
CC9 A808
CC13 A809
CC15 A809
CCID A606
CG1 A808
CG2 A808
CG5 A808
CG6 A808
CG9 A808
CIGFT2 A604
CIGFT3 A604
CIGFT5 A605
CKN1/26 A805
CKN3 A808
CKN55 A808
CKN75 A808
CL84 A810
CL84X A810

CL85 A810
CL85X A810
CL86 A810
CL86X A810
CL87 A810
CL87X A810
CL88 A810
CL88X A810
CL846 A810
CL856 A810
CL866 A810
CL876 A810
CL886 A810
CLC40C A804
CLC40CWM A804
CLC40L A804
CLG A619
CLGS A619
CLR6 A520
CM2 A811
CM2/4 A811
CM2/4S6 A811
CM2/4X A811
CM4 A811
CM4L A811
CM4R A812
CM5L A812
CM6R A812
CM8 A812
CM9 A812
CM10 A811
CM11 A811
CM12 A811
CM12S6 A811
CM18 A809
CM26 A811
CM46 A811
CM86 A812
CM96 A812
CM106 A811
CM116 A811
CM126 A811
CO1 A805
CO2 A805
CO26 A805
CO36 A805
CO46 A805
CP3/4 A607
CP8/9H6 A607
CP8/9H9 A607
CP17/186 A607
CPF4 A806
CPF16 A806
CPF26 A806
CPF36 A806
CPF46 A806
CR206 A613

CR216 A613
CRB A871
CRBL A871
CRC A871
CRCH1 A617
CRCH2 A617
CRLABANCA A872
CRM A871
CRM2 A871
CRMS A871
CRMT A871
CRMX A871
CRNT12 A613
CRO2 A872
CRO3 A872
CRPA A872
CRPC A872
CRSA A872
CRURBAN A871
CRW1 A872
CRW2 A872
CS246 A618
CSEUWES6 A839
CSLABANCA6 A838
CSOLT3/46 A806
CTG A806
CTG6 A806
CTG-O A806
CTG-O6 A806
CUPE A837
CURBAN1 A806
CURBAN2 A806
CVHL1 A612
CVHL2 A612
CVWI86 A612
CW1 A809
CW2 A809

D

DP2 A309
DP18 A309
DP18L A309 A521
DP317 A309
DP365B C102
DP365M10 C103
DPC365M C102
DPU17 A309
DSCFINE A203
DSCMED A203
DSCSET A203
DSCXFINE A203

E

E1 A817
E1C A817
E1L A816
E1LX A816
E1R A816
E1RX A816
E2 A817
E2C A817
E2S A816
E3C A817
E3S A816
E4 A815
E4L A816
E4R A816
E5 A815
E6 A819
E6X A818
E7 A819
E7X A818
E8 A819
E9 A880
E9L A880
E9L6 A880
E9R A880
E9R6 A880
E11 A818
E11A A818
E11H A818
E11LX A816
E11M A818
E11RX A816
E12 A818
E12LX A816
E12M A818
E12RX A816
E13M A818
E14LX A816
E14RX A816
E15 A818
E16 A818
E19 A818
E20 A818
E21 A817
E22 A817
E23 A818
E25 A817
E26 A817
E31 A817
E31F A818
E32 A817
E32F A818
E34 A816
E34S A816
E34SSERR A816
E34SSM A816
E38 A819
E39 A819
E40 A817
E41 A817
E44 A817
E44C A819
E45 A817
E46 A819
E46R A819
E51 A819
E52 A819
E63 A819
E71 A815
E72 A815
E73 A815
E74 A815
E77 A819
E77R A819
E77RSM A819
E80 A819
E81 A819
E81A A819
E81E A819
E92 A819
E93 A819
E94 A880
E95 A880
E96 A880
E98 A819
E190 A818
E191 A818
E301 A815
E301SERR A815
E301SM A815
E301W A816
E302 A815
E303 A815
E304W A816
EA A820
EA1C A817
EA2C A817
EA3C A817
EA30 A817
EA31 A817
EB A820
EBSM A820
ED1 A881
ED2 A881
ED3 A881
ED4 A881
ED10 A881
ED11 A881
ED16 A881
ED26 A881
ED36 A881
ED106 A881

- ED116** A881
EDLL3 A820
EDLL5 A820
EDLR3 A820
EDLR5 A820
EH5 A820
EH6 A820
EHB1 A881
EHB2 A882
EHB2H A882
EHB3 A882
EHB3H A882
EHB4 A882
EHB5 A882
EHB13/14 A882
EHB13/14H A882
EHB13/14H6 A882
EHB13/14X A882
EHB13/146 A882
EHO1 A882
EHO2 A882
EHO2/3 A882
EHO2/36 A882
EHO3 A882
EHO4 A882
EL2C A821
EL2CX A821
EL2S A821
EL2SX A821
EL3C A821
EL3CX A821
EL4C A821
EL4CX A821
EL4S A821
EL4SX A821
EL5C A821
EL5CX A821
EL5S A821
EL5SX A821
ELSLIM2CL A822
ELSLIM2CLX A822
ELSLIM2CS A822
ELSLIM2CSX A822
ELSLIM2SL A822
ELSLIM2SLX A822
ELSLIM2SS A822
ELSLIM2SSX A822
ELSLIM3CL A822
ELSLIM3CLX A822
ELSLIM3CS A822
ELSLIM3CSX A822
ELSLIM3SL A822
ELSLIM3SLX A822
ELSLIM3SS A822
ELSLIMSSX A822
EMLL3 A820
EMLL5 A820
EMLR3 A820
EMLR5 A820
EPL1 A521
EPTLGD A823
EPTLGDX A823
EPTLGM A823
EPTLGMX A823
EPTSMC A823
EPTSMCX A823
EPTSMD A823
EPTSMDX A823
EPTSMM A823
EPTSMMX A823
EPTSMS A823
EPTSMSX A823
EPTSSP A823
EPTSSPX A823
ERAF1 A882
ERAF3KA A883
EW1 A883
EW2 A883
EW3 A883
EW4 A883
EW5 A883
EW6 A883
EW26 A883
EW36 A883
EW46 A883
EW56 A883
EW66 A883
EWJL A820
EWJR A820
EWJS A820
EWS16 A883
EXC17W A609
EXC18W A609
EXC19 A608
EXC19W A609
EXC31L6 A514
EXC31W6 A514
EXC32L6 A514
EXC33L6 A514
EXC36/37 A609
EXC36/376 A609
EXC176 A608
EXC186 A608
EXC196 A608
EXC220/1 A609
EXC220/16 A609
EXC242 A609
EXC243 A609
EXC246 A609
EXC2429 A609
EXC2466 A609
EXC2469 A609
EXCE1 A608
EXCE16 A608
EXCGL2 A514
EXD5XTS A306
EXD11/12A6 A306
EXD11/126 A306
EXD16 A306
EXD56 A306
EXDG16/17 A513
EXDG16/23 A513
EXDG166 A513
EXDG167 A513
EXTU17/236 A306
F
F1 A833
F1A A833
F1IS A827
F1S A835
F1XS A829
F3FS A831
F10S A832
F13XS A829
F16 A830
F16M A830
F16S A835
F17 A830
F18L A832
F18R A832
F23 A831
F23IS A827
F23K A834
F23S A835
F23XS A829
F32 A833
F32A A833
F35XS A829
F36XS A829
F39 A835
F40 A835
F53L A832
F53LIS A827
F53R A832
F53RIS A827
F62 A833
F65 A836
F67XS A829
F69 A836
F69IS A828
F88L A832
F88LIS A828
F88R A832
F88RIS A828
F89 A832
F90 A832
F99C A833
F101 A833
F150 A833
F150A A833
F150AS A833
F150IS A827
F150K A834
F150S A835
F150SR A835
F150XAS A835
F151 A831
F151A A830
F151AS A830
F151IS A827
F151K A834
F151S A835
F151SR A835
F151XAS A835
F203 A830
F210H A832
F210S A832
F217 A830
F222 A831
F222IS A827
F286 A833
F300 A836
F301 A836
FAF1 A828
FAF1IS A828
FAF1XS A829
FAF35XS A829
FAF36XS A829
FAF150 A828
FAF150IS A828
FAF151 A828
FAF151IS A828
FAF222 A828
FAF222IS A828
FAFX67A A828
FAFX74N A828
FB11/12 A826
FB11/126 A826
FMD1 A833
FMD2 A832
FMD3 A830
FMD4 A831
FQUINCEY1X A852
FQUINCEY2X A852
FRCE A809
FS1/2S A826
FS1/2S6 A826
FS3/4S A826
FS3/4S6 A826
FS9/10S A826
FS9/10S6 A826
FX1 A834
FX1CE A834
FX1E A834
FX2CE A834

FX3CE A834
FX4CE A834
FX5CE A834
FX6CE A834
FX7 A834
FX7CE A834
FX7E A834
FX13 A830
FX13E A830
FX17 A832
FX17E A832
FX18 A832
FX18E A832
FX22 A831
FX22E A831
FX33 A836
FX35E A834
FX45XS A829
FX46L A836
FX46LE A836
FX49 A836
FX49E A836
FX51 A836
FX51E A836
FX51XS A829
FX67A A832
FX73 A831
FX73XS A829
FX74 A836
FX74N A836
FX76S A836
FX79 A831
FX79E A831
FX79XS A829
FX97 A836
FX97E A836
FX233 A836
FX233E A836

G

GCP113NS6 A616
GCP1136 A616
GCPBAL A616
GCPS66 A616
GCPYD16 A616
GCR45 A617
GCROS A617
GF36 A613
GRK1 A615
GRM1 A615
GRM2 A615
GRM3 A615
GRM4 A615

H

H1 A840
H2 A840
H3 A840
H4 A840
H5 A840
HAC A840
HAS A840
HHC A841
HHS A841
HKC A841
HKRC A841
HKRS A841
HOEXTER1 A812
HOEXTER2 A812
HOEXTER3 A812
HOEXTER4 A861
HRPC A841

I

IL/OL A618
IM30HU0 B110
IM30HU0RL B120
IM30HU1 B110
IM30HU1RL B120
IM30HU2 B110
IM30HU2RL B120
IM30HU3 B110
IM30HU3RL B120
IM30HU5 B110
IM30HU5RL B120
IM30HU6 B110
IM30HU6RL B120
IM30HU8 B110
IM30HU8RL B120
IM30HU9 B110
IM30HU9RL B120
IM60H0 B110
IM60H0RAIL B121
IM60H1 B110
IM60H1RAIL B121
IM60H2 B110
IM60H2RAIL B121
IM60H3 B110
IM60H3RAIL B121
IM60H5 B110
IM60H5RAIL B121
IM60H6 B110
IM60H6RAIL B121
IM60H8 B110
IM60H8RAIL B121
IM60H9 B110
IM60H9RAIL B121

IM1000 B113
IM1001 B113
IM1002 B113
IM1003 B113
IM1004 B113
IM1005 B112
IM1005N B112
IM1006 B112
IM4120 B109
IM4121 B109
IM4122 B109
IM4123 B109
IM4125 B109
IM4126 B109
IM4128 B109
IM4129 B109
IM4160 B109
IM4160RAIL B120
IM4161 B109
IM4161RAIL B120
IM4162 B109
IM4162RAIL B120
IM4163 B109
IM4163RAIL B120
IM4165 B109
IM4165RAIL B120
IM4166 B109
IM4166RAIL B120
IM4168 B109
IM4168RAIL B120
IM4169 B109
IM4169RAIL B120
IM4200 B109
IM4200RAIL B121
IM4201 B109
IM4201RAIL B121
IM4202 B109
IM4202RAIL B121
IM4203 B109
IM4203RAIL B121
IM4205 B109
IM4205RAIL B121
IM4206 B109
IM4206RAIL B121
IM4208 B109
IM4208RAIL B121
IM4209 B109
IM4209RAIL B121
IM5080 B108
IM5080RAIL B120
IM5081 B108
IM5081RAIL B120
IM5082 B108
IM5082RAIL B120
IM5083 B108
IM5083RAIL B120
IM5085 B108

IM5085RAIL B120
IM5086 B108
IM5086RAIL B120
IM5088 B108
IM5088RAIL B120
IM5089 B108
IM5089RAIL B120
IM5100 B108
IM5100RAIL B120
IM5101 B108
IM5101RAIL B120
IM5102 B108
IM5102RAIL B120
IM5103 B108
IM5103RAIL B120
IM5105 B108
IM5105RAIL B120
IM5106 B108
IM5106RAIL B120
IM5108 B108
IM5108RAIL B120
IM5109 B108
IM5109RAIL B120
IM5200-OR B111
IM5200-ORR B121
IM5201-OR B111
IM5201-ORR B121
IM5202-OR B111
IM5202-ORR B121
IM5203-OR B111
IM5203-ORR B121
IM5205-OR B111
IM5205-ORR B121
IM5206-OR B111
IM5206-ORR B121
IM5208-OR B111
IM5208-ORR B121
IM5209-OR B111
IM5209-ORR B121
IM6050 B108
IM6050RAIL B121
IM6051 B108
IM6051RAIL B121
IM6052 B108
IM6052RAIL B121
IM6053 A602 A602
IM6053RAIL B121
IM6055 B108
IM6055RAIL B121
IM6056 B108
IM6056RAIL B121
IM6058 B108
IM6058RAIL B121
IM6059 B108
IM6059RAIL B121
IM8120 B108
IM8120RAIL B122

- IM8121 B108
- IM8121RAIL B122
- IM8122 B108
- IM8122RAIL B122
- IM8123 B108
- IM8123RAIL B122
- IM8125 B108
- IM8125RAIL B122
- IM8126 B108
- IM8126RAIL B122
- IM8128 B108
- IM8128RAIL B122
- IM8129 B108
- IM8129RAIL B122
- IM9080 B109
- IM9080RAIL B122
- IM9081 B109
- IM9081RAIL B122
- IM9082 B109
- IM9082RAIL B122
- IM9083 B109
- IM9083RAIL B122
- IM9085 B109
- IM9085RAIL B122
- IM9086 B109
- IM9086RAIL B122
- IM9088 B109
- IM9088RAIL B122
- IM9089 B109
- IM9089RAIL B122
- IM9140 B109
- IM9140-OR B111
- IM9140RAIL B122
- IM9141 B109
- IM9141-OR B111
- IM9141RAIL B122
- IM9142 B109
- IM9142-OR B111
- IM9142RAIL B122
- IM9143 B109
- IM9143-OR B111
- IM9143RAIL B122
- IM9145 B109
- IM9145-OR B111
- IM9145RAIL B122
- IM9146 B109
- IM9146-OR B111
- IM9146RAIL B122
- IM9148 B109
- IM9148-OR B111
- IM9148RAIL B122
- IM9149 B109
- IM9149-OR B111
- IM9149RAIL B122
- IM9200 B110
- IM9200RAIL B122
- IM9201 B110
- IM9201RAIL B122
- IM9202 B110
- IM9202RAIL B122
- IM9203 B110
- IM9203RAIL B122
- IM9205 B110
- IM9205RAIL B122
- IM9206 B110
- IM9206RAIL B122
- IM9208 B110
- IM9208RAIL B122
- IM9209 B110
- IM9209RAIL B122
- IMN30HU0 B106
- IMN30HU1 B106
- IMN30HU2 B106
- IMN30HU3 B106
- IMN30HU4 B106
- IMN30HU5 B106
- IMN30HU6 B106
- IMN30HU7 B106
- IMN30HU8 B106
- IMN30HU9 B106
- IMN30HU11 B106
- IMN60H0 B106
- IMN60H1 B106
- IMN60H2 B106
- IMN60H3 B106
- IMN60H4 B106
- IMN60H5 B106
- IMN60H6 B106
- IMN60H7 B106
- IMN60H8 B106
- IMN60H9 B106
- IMN60H11 B106
- IMN4120 B104
- IMN4121 B104
- IMN4122 B104
- IMN4123 B104
- IMN4124 B104
- IMN4125 B104
- IMN4126 B104
- IMN4127 B104
- IMN4128 B104
- IMN4129 B104
- IMN4160 B104
- IMN4161 B104
- IMN4162 B104
- IMN4163 B104
- IMN4164 B104
- IMN4165 B104
- IMN4166 B104
- IMN4167 B104
- IMN4168 B104
- IMN4169 B104
- IMN4200 B104
- IMN4201 B104
- IMN4202 B104
- IMN4203 B104
- IMN4204 B104
- IMN4205 B104
- IMN4206 B104
- IMN4207 B104
- IMN4208 B104
- IMN4209 B104
- IMN5080 B103
- IMN5081 B103
- IMN5082 B103
- IMN5083 B103
- IMN5084 B103
- IMN5085 B103
- IMN5086 B103
- IMN5087 B103
- IMN5088 B103
- IMN5089 B103
- IMN5100 B103
- IMN5101 B103
- IMN5102 B103
- IMN5103 B103
- IMN5104 B103
- IMN5105 B103
- IMN5106 B103
- IMN5107 B103
- IMN5108 B103
- IMN5109 B103
- IMN6050 B102
- IMN6051 B102
- IMN6052 B102
- IMN6053 B102
- IMN6054 B102
- IMN6055 B102
- IMN6056 B102
- IMN6057 B102
- IMN6058 B102
- IMN6059 B102
- IMN8120 B103
- IMN8121 B103
- IMN8122 B103
- IMN8123 B103
- IMN8124 B103
- IMN8125 B103
- IMN8126 B103
- IMN8127 B103
- IMN8128 B103
- IMN8129 B103
- IMN9080 B105
- IMN9081 B105
- IMN9082 B105
- IMN9083 B105
- IMN9084 B105
- IMN9085 B105
- IMN9086 B105
- IMN9087 B105
- IMN9088 B105
- IMN9089 B105
- IMN9140 B105
- IMN9140-O B107
- IMN9141 B105
- IMN9141-O B107
- IMN9142 B105
- IMN9142-O B107
- IMN9143 B105
- IMN9143-O B107
- IMN9144 B105
- IMN9144-O B107
- IMN9145 B105
- IMN9145-O B107
- IMN9146 B105
- IMN9146-O B107
- IMN9147 B105
- IMN9147-O B107
- IMN9148 B105
- IMN9148-O B107
- IMN9149 B105
- IMN9149-O B107
- IMN9200 B105
- IMN9201 B105
- IMN9202 B105
- IMN9203 B105
- IMN9204 B105
- IMN9205 B105
- IMN9206 B105
- IMN9207 B105
- IMN9208 B105
- IMN9209 B105
- IMN41211 B104
- IMN41611 B104
- IMN42011 B104
- IMN50811 B103
- IMN51011 B103
- IMN60511 B102
- IMN81211 B103
- IMN90811 B105
- IMN91411 B105
- IMN91411-O B107
- IMN92011 B105
- IMNORTHL4 B107
- IMNORTHL8 B107
- IMNORTHL9 B107
- IMNORTHSH4 B107
- IMNORTHSH8 B107
- IMNORTHSH9 B107
- IMNOSO B106
- IMNOS1 B106
- IMNOS2 B106
- IMNOS3 B106
- IMNOS4 B106
- IMNOS5 B106
- IMNOS6 B106
- IMNOS7 B106
- IMNOS8 B106

IMNOS9 B106
IMNOS11 B106
IMORTHLG8 B111
IMORTHSM8 B111
IMORTL8RL B123
IMORTS8RL B123
IMOSO B110
IMOSORAIL B123
IMOS1 B110
IMOS1RAIL B123
IMOS2 B110
IMOS2RAIL B123
IMOS3 B110
IMOS3RAIL B123
IMOS5 B110
IMOS5RAIL B123
IMOS6 B110
IMOS6RAIL B123
IMOS8 B110
IMOS8RAIL B123
IMOS9 B110
IMOS9RAIL B123
IMP204SDT A402
IMP300S6 A843
IMP300SIM A843
IMP300X A843
IMP3006 A843
IMP6343S A843
IMP6343S6 A843
IMP6344S A843
IMP6344S6 A843
IMP6345-71 A843
IMP6345S A843
IMP6345S6 A843
IMP6346S A843
IMP6346S6 A843
IMP6347S A843
IMP6347S6 A843
IMP6348S A843
IMP6522 A838
IMP6522X A838
IMP6523S A838
IMP6523S6 A838
IMP6524S A838
IMP6524S6 A838 A844
IMP6577SC A844
IMP6577SC6 A844
IMP6577SCX A844
IMP6578 A844
IMP6578SX A844
IMP7044K A844
IMP63456 A843
IMP65226 A838
IMP65786 A844
IMPCKITII A403
IMPHDL6 A403
IMPJO6 A844

IMPJO66 A844
IMPL4R/4L A403
IMPL4R/4L6 A403
IMPL204S A403
IMPL204S6 A403
IMPLBH5/6 A403
IMPLBH5/66 A403
IMPLG1/2T A402
IMPLH6/7 A403
IMPLH6/76 A403
IMPLINTRO6 A403
IMPLLG1/2 A403
IMPLLG1/26 A403
IMPLSORT A403
IMPLSORT6 A403
IMPM1/2T A402
IMPM11/12T A402
IMPM13/14T A402
IMPROMP16 A844
IMPROMP26 A844
IMPROMP36 A844
IMPSIM1 A845
IMPSIM16 A845
IMPSIM36 A846
IMPSTE1/26 A845
IMPURBA1S6 A845
IMPURBA2S6 A845
IMPURBAN16 A845
IMPURBAN26 A845
IMPURBAN36 A845
IMS-1200H B203
IMS-1200U B203
IMS-1200W B203
IMS-1229 B202
IMS-1271 B112
IMS-1273 B112
IMS-1275 B112
IMS-1275D B112
IMS-1280 B114
IMS-1280L B114
IMS-1281 B114
IMS-1281L B114
IMS-1282 B114
IMS-1282L B114
IMS-1283 B114
IMS-1283L B114
IMS-1284 B114
IMS-1284L B114
IMS-1285 B114
IMS-1285L B114
IMS-1286 B114
IMS-1286L B114
IMS-1287 B114
IMS-1287L B114
IMS-1288 B114
IMS-1288L B114
IMS-1289 B114

IMS-1289L B114
IMS-1290N B114
IMS-1291N B114
IMS-1292N B114
IMS-1293N B114
IMS-1294N B114
IMS-1295N B114
IMS-1296N B114
IMS-1297N B114
IMS-1298N B114
IMS-1299N B114
IMS-1372S B113
IMS-1372SH B113
IMS-1372T B113
IMS-1372TH B113
IMS-1378 B112
IMS-1379 B112
IMS-1455 B203
IMS-12810 B114
IMS-12810L B114
IMS-12811 B114
IMS-12811L B114
IMS-12812 B114
IMS-12812L B114
IMS-12813 B114
IMS-12813L B114
IMS-12910N B114
IMS-12911N B114
IMS-12912N B114
IMS-12913N B114
IPZ1 A846
IPZ2 A846
IPZ3 A846
IPZ16 A846
IPZ26 A846
IPZ36 A846
IR A875
IS A894

K

K360 A885
KB3/46 A850
KB5/66 A850
KCK3 A850
KCK36 A850
KGF11X A850
KGF76 A850
KGF86 A850
KGF96 A850
KGF116 A850
KK15 A850
KK15/16S6 A850
KK15/16SX A850
KK15/16X A850
KK15/166 A850

KK15/169 A850
KK16 A850
KK156 A850
KK166 A850
KKN76 A851
KKN116 A851
KO1 A851
KO1/2X A851
KO1/26 A851
KO1/29 A851
KO12KP3R4X A851
KO12KP3R49 A851
KO12KPO3A6 A851
KO12KPO3A9 A851
KO12KPO3AR A851
KO12KPO3AX A851
KO12KPO3R9 A851
KO12KPO3RX A851
KO16 A851
KPA A851
KPAX A851
KPQ A886
KRDY1 A851
KRDY2 A851
KS1/26 A852
KSOLT1/26 A852
KUSC6 A852

L

LDP A714
LENS A204

M

MAL1 A853
MAR-C1 A510
MAR-C2 A510
MAR-C3 A510
MAR-C4 A510
MAR-EX1 A512
MAR-SAC1 A510
MAR-SAC1.5 A510
MAR-SAC2 A510
MAR-SAC3 A510
MAR-SAC.5 A510
MAR-SC1 A509
MAR-SC2 A509
MAR-SC3 A509
MAR-SC4 A509
MBW A886
MCBL A511
MCBLM A511
MCBLS A511
MCBRL A511

MCBRM A511
MCBRS A511
MEX1 A512
MGA A853
MGC A853
MGI A853
MIR4 A308
MIR4/3 A308
MIR4/12 A308
MIR4DS A308
MIR4DS/3 A308
MIR4DSHD A308
MIR4HD A308
MIR5 A308
MIR5/3 A308
MIR5DS A308
MIR5DS/3 A308
MIR5DS/6 A308
MIR5DSHD A308
MIR5DSHDB A307
MIR5HD A308
MIR5HDB A307
MM1 A508
MM2 A508
MM3 A508
MM4 A509
MM5 A509
MM7 A509
MM8 A509
MMR A508
MMRS A508
MMVEL1 A509
MMVEL2 A509
MP48 A854
MP52 A854
MP54 A854
MRFL A512
MRFR A512
MT286 A607
MT296 A607

N

NH5020 A857
NH5020M A858
NH5020R A857
NH5021 A858
NH5021M A858
NH5021RC A858
NH5022 A854
NH5024 A858
NH5024CORT A858
NH5024R A858
NH5024RC A858
NH5024SIM A858
NH5030 A854

NH5032 A855
NH5034 A855
NH5036 A855
NH5037 A855
NH5038 A855
NH5038L A855
NH5042 A855
NH5044 A855
NH5046 A856
NH5050 A856
NH5052 A856
NH5068 A856
NH5072 A856
NH5074 A856
NH5074E A856
NH5076 A856
NH5082 A857
NH5084 A857
NH5092 A857
NH5094 A857
NHB A860
NHC A859
NHCV A859
NHCV18 A859
NHCW A859
NHD A860
NHDCPV A859
NHDCPVN A859
NHDPV A859
NHDPVN A859
NHGILFINE A860
NHHB A860
NHLBPSB A857
NHLBPSE A857
NHM A860
NHM-5025R A858
NHM-5026R A858
NHM-5027 A859
NHM-5028 A859
NHMH A860
NHOH A860
NHSLSCHLEE A858
NHTMBH A859
NHW A860
NIPRO A903
NIPS A903

O

OSS6518S A847
OSS6519CS A847
OSS6520S A847
OSS6521CS A847
OSTJ08 A848
OSTMGRIF A848
OSTMPU27 A849

OSTMPU27A A849
OSTMPU32 A849
OSTMPU32A A849
OSTMPU37 A849
OSTMPU37A A849
OSTMPU42 A849
OSTMPU42A A849
OSTMPU50 A849
OSTMPU50A A849
OSTMSH27 A849
OSTMSH27A A849
OSTMSH32 A849
OSTMSH32A A849
OSTMSH37 A849
OSTMSH37A A849
OSTMSH42 A849
OSTMSH42A A849
OSTMSH50 A849
OSTMSH50A A849
OSTMSP27 A849
OSTMSP27A A849
OSTMSP32 A849
OSTMSP32A A849
OSTMSP37 A849
OSTMSP37A A849
OSTMSP42 A849
OSTMSP42A A849
OSTMSP50 A849
OSTMSP50A A849
OSTPAL1 A848
OSTPAL2 A848
OSTPAL3 A848
OSTPAL4 A848

P

P1H6 A861 A862
P2 A862
P3 A863
P5 A863
P8D A863
P8D6 A863
P9 A864
P9A A864
P9A6 A864
P9H A864
P9H6 A864
P9/PA A864
P9/PA6 A864
P9X A864
P12S A861
P12S6 A861
P14 A861
P14X A861
P15 A862
P15/11.5B6 A305
P16 A862
P20 A862
P20SIC A862
P20SIC6 A862
P23 A863
P24G A863
P24GSIC A863
P24GSIC6 A863
P24GSP A863
P24GSP6 A863
P24GSPX A863
P26 A862
P36 A863
P96 A864
P146 A861
P149 A862
P156 A862
P166 A862
P206 A862
P1496 A862
PBQ A864
PBQ6 A864
PBTPB A303
PBTPG A303
PBTPKIT12 A303
PBTPW A303
PCP11.5B6 A305
PCP116 A304
PCP126 A304
PCP6500 A846
PCP65006 A846
PCPUNC126 A304
PCPUNC156 A304
PCV11KIT6 A302
PCV12PT A302
PCVNCKIT6 A302
PCVO12PT A302
PCVOKIT6 A303
PCVUNC12PT A302
PCVWPT A302
PDEMIRELS6 A864
PDONOS A864
PEREURX A870
PESIM1 A845
PESIM16 A845
PFI8ABK6 A512
PFIAB2 A605
PFIDD1/2 A602
PFIDD1/28 A602
PFIDD3/4 A602
PFIDD3/48 A602
PFIDD5/6 A602
PFIDD5/68 A602
PFIDD7/8 A602
PFIDD7/88 A602
PFIDD9/10 A602
PFIDD9/108 A602

PFIDDCASS A602
PFIDDCASS8 A602
PFIGML1 A606
PFIWDS1MK A865
PFIWDS1MKX A865
PFIWDS1S6 A865
PFIWDS1X A865
PFN A865
PGR1 A865
PH1 A865
PH2 A865
PH2KALLA A865
PH26 A865
PH26M A865
PHO6 A303
PICH A610
PICH6 A610
PJO/1 A806
PJO/2 A806
PJO/2M6 A807
PJO/3 A807
PJO/3M6 A807
PJO/16 A806
PJO/26 A806
PJO/36 A807
PK2-5080RL B116
PK2-5081RL B116
PK2-5082RL B116
PK2-5083RL B116
PK2-5084RL B116
PK2-5085RL B116
PK2-5086RL B116
PK2-5087RL B116
PK2-5088RL B116
PK2-5089RL B116
PK2-5100RL B117
PK2-5101RL B117
PK2-5102RL B117
PK2-5103RL B117
PK2-5104RL B117
PK2-5105RL B117
PK2-5106RL B117
PK2-5107RL B117
PK2-5108RL B117
PK2-5109RL B117
PK2-6050RL B117
PK2-6051RL B117
PK2-6052RL B117
PK2-6053RL B117
PK2-6054RL B117
PK2-6055RL B117
PK2-6056RL B117
PK2-6057RL B117
PK2-6058RL B117
PK2-6059RL B117
PK2-50811R B116
PK2-51011R B117
PK2-60511R B117
PK-30HU0RL B115
PK-30HU1RL B115
PK-30HU2RL B115
PK-30HU3RL B115
PK-30HU4RL B115
PK-30HU5RL B115
PK-30HU6RL B115
PK-30HU7RL B115
PK-30HU8RL B115
PK-30HU9RL B115
PK-30HU11R B115
PK-60H0RL B117
PK-60H1RL B117
PK-60H2RL B117
PK-60H3RL B117
PK-60H4RL B117
PK-60H5RL B117
PK-60H6RL B117
PK-60H7RL B117
PK-60H8RL B117
PK-60H9RL B117
PK-60H11RL B117
PK-4120RL B115
PK-4121RL B115
PK-4122RL B115
PK-4123RL B115
PK-4124RL B115
PK-4125RL B115
PK-4126RL B115
PK-4127RL B115
PK-4128RL B115
PK-4129RL B115
PK-4160RL B115
PK-4161RL B115
PK-4162RL B115
PK-4163RL B115
PK-4164RL B115
PK-4165RL B115
PK-4166RL B115
PK-4167RL B115
PK-4168RL B115
PK-4169RL B115
PK-4200RL B116
PK-4201RL B116
PK-4202RL B116
PK-4203RL B116
PK-4204RL B116
PK-4205RL B116
PK-4206RL B116
PK-4207RL B116
PK-4208RL B116
PK-4209RL B116
PK-8120RL B117
PK-8121RL B117
PK-8122RL B117
PK-8123RL B117
PK-8124RL B117
PK-8125RL B117
PK-8126RL B117
PK-8127RL B117
PK-8128RL B117
PK-8129RL B117
PK-9080RL B118
PK-9081RL B118
PK-9082RL B118
PK-9083RL B118
PK-9084RL B118
PK-9085RL B118
PK-9086RL B118
PK-9087RL B118
PK-9088RL B118
PK-9089RL B118
PK-9140RL B118
PK-9141RL B118
PK-9142RL B118
PK-9143RL B118
PK-9144RL B118
PK-9145RL B118
PK-9146RL B118
PK-9147RL B118
PK-9148RL B118
PK-9149RL B118
PK-9200RL B119
PK-9201RL B119
PK-9202RL B119
PK-9203RL B119
PK-9204RL B119
PK-9205RL B119
PK-9206RL B119
PK-9207RL B119
PK-9208RL B119
PK-9209RL B119
PK-41211RL B115
PK-41611RL B115
PK-42011RL B116
PK-81211RL B117
PK-90811RL B118
PK-91411RL B118
PK-92011RL B119
PKE-4120R B115
PKE-4121R B115
PKE-4122R B115
PKE-4123R B115
PKE-4124R B115
PKE-4125R B115
PKE-4126R B115
PKE-4127R B115
PKE-4128R B115
PKE-4129R B115
PKE-4160R B115
PKE-4161R B115
PKE-4162R B115
PKE-4163R B115
PKE-4164R B115
PKE-4165R B115
PKE-4166R B115
PKE-4167R B115
PKE-4168R B115
PKE-4169R B115
PKE-4200R B116
PKE-4201R B116
PKE-4202R B116
PKE-4203R B116
PKE-4204R B116
PKE-4205R B116
PKE-4206R B116
PKE-4207R B116
PKE-4208R B116
PKE-4209R B116
PKE-8120R B117
PKE-8121R B117
PKE-8122R B117
PKE-8123R B117
PKE-8124R B117
PKE-8125R B117
PKE-8126R B117
PKE-8127R B117
PKE-8128R B117
PKE-8129R B117
PKE-41211R B115
PKE-41611R B115
PKE-42011R B116
PKE-81211R B117
PKE-OS0R B119
PKE-OS1R B119
PKE-OS2R B119
PKE-OS3R B119
PKE-OS4R B119
PKE-OS5R B119
PKE-OS6R B119
PKE-OS7R B119
PKE-OS8R B119
PKE-OS9R B119
PKE-OS11R B119
PKN1 A866
PKN16 A866
PKN152 A866
PKN152SX A866
PKN152X A866
PKN1526 A866
PK-ORTL4L B116
PK-ORTL8L B116
PK-ORTL9L B116
PK-ORTS4L B116
PK-ORTS8L B116
PK-ORTS9L B116
PK-OS0RAIL B119
PK-OS1RAIL B119
PK-OS2RAIL B119
PK-OS3RAIL B119

PK-OS4RAIL B119
PK-OS5RAIL B119
PK-OS6RAIL B119
PK-OS7RAIL B119
PK-OS8RAIL B119
PK-OS9RAIL B119
PK-OS11RAI B119
PLGGR1 A839
PLGGR1S6 A839
PLGGR1X A839
PLGJO/4 A839
PLGJO/4X A839
PLGJO/46 A839
PLGJO/56 A839
PLGLABANC6 A839
PLGLABANCX A839
PLGROMP1X A839
PLGROMP2X A839
PLGTAHM A839
PMALO A866
PMNANOAS A852
PMNANOSS A852
PMP7002 A838
PMPI A838
PMPI6 A838
PMPIE A838
PMPIS A838
PMPIS6 A838
PMPIX A838
PMPRODIGYS A813
PMSPLITSX A866
PP25 A866
PP5590SIM A866
PPAEL A867
PPAELA A867
PPAELAS6 A867
PPAELASX A867
PPAELAX A867
PPAELP A867
PPAELPSX A867
PPAELPX A867
PPAELS6 A867
PPAELSX A867
PPAELX A867
PPBUH2M2X A867
PPBUH2MX A867
PPBUSE1/26 A867
PPBUSE1/36 A867
PPBUSE2/36 A807
PPBUSER A867
PPBUSER1/2 A807
PPBUSER2/3 A807
PPBUSER6 A867
PPBUSER12X A807
PPBUSER23X A807
PPBUSERSX A867
PPBUSERX A867

PPIS A838
PPLABAN2S6 A868
PPLABANC3X A868
PPLABANC26 A868
PPLABANC36 A868
PPLABANCA A868
PPLABANCA2 A868
PPLABANCA3 A868
PPLABANCA6 A868
PPR3 A868
PPR3/9A A868
PPR3/9A6 A868
PPR3M A868
PPR3S A868
PPR3S6 A868
PPR3X A868
PPR36 A868
PPSG12PT A304
PPSGKIT6 A304
PPSPAHR6 A868
PPSTEIG A869
PQ2N6 A305
PQW6 A304
PROG A619
PROGS A619
PT1X A870
PT2X A870
PT3X A870
PT4X A870
PT5X A870
PT6X A870
PTAA A803
PTIST A894
PTNFM1 A853
PTROM16 A869
PTRTA A853
PTRTC A853
PTRTI A853
PTS A204
PWILL A869

R

R1 A876
R1A A877
R3H A877
R4 A877
R4A A877
R5 A877
R5S A877
R15 A876
R18M A878
RASP A842
RBAY A878
RBL A878
RBL45 A878

RBL90 A878
RBOE A878
RBOEC A878
RCP1/3 A518
RCP5/7 A518
RCP9/11 A518
RCP30 A517
RCP40 A517
RCP50 A517
RCP60 A517
RCPGL1 A518
RCPM1/2 A518
RCPM3/4 A518
RCS25NT A516
RCS25SNT A516
RCSD11 A515
RCSD11NT A516
RCSD11S A515
RCSD11T A515
RCSD11TS A515
RCSD11TSNT A516
RCSW1S A515
RDAF6 A506
RDCF5 A506
RDCM0 A502
RDCMOX A502
RDCM1 A502
RDCM1X A502
RDCM2 A502
RDCM2A A502
RDCM2AS A502
RDCM2ASX A502
RDCM2AX A502
RDCM2X A502
RDCM4 A504
RDCM4X A504
RDCM7 A504
RDCM7A A504
RDCM7AX A504
RDCM7X A504
RDCM8 A504
RDCM8X A504
RDCM9 A502
RDCM9X A502
RDCM10 A503
RDCM10X A503
RDCM11 A503
RDCM11X A503
RDCM12A A504
RDCM12AX A504
RDCM13A A504
RDCM13AX A504
RDCM14 A503
RDCM14A A503
RDCM14AX A503
RDCM14X A503
RDCM18 A503

RDCM18X A503
RDCM24 A503
RDCM24X A503
RDCM25 A503
RDCM25X A503
RDCM26N A504
RDCM26NX A504
RDCM27 A503
RDCM27N A502
RDCM27NX A502
RDCM27X A503
RDCM56 A503
RDCM56S A503
RDCM56SX A503
RDCM56X A503
RDCM201 A504
RDCM201X A504
RDCM212 A502
RDCM212X A502
RDCMW4 A504
RDCMW4X A504
RDCOB A506 B113
RDF A506
RDF4 A506
RDP A505
RDPA A505
RF A879
RF45 A519
RF90 A520
RFP A520
RFSTR A519
RKN A877
RKSN A879
RMF A879
RMF90 A879
RSMID1 A875
RSMID2 A875

S

S1 A887
S1L A888
S2 A888
S2L A889
S3 A889
S4 A889
S5 A890
S6 A891
S7 A891
S8 A891
S9 A891
S10 A887
S10SC A887
S11 A887
S12 A887
S13 A887

S13K/13KL A807
S13K/13KL6 A807
S13K/13KL9 A807
S13K/13KLX A807
S13K/TG A807
S13K/TG6 A807
S13K/TG9 A807
S13K/TGS6 A807
S13K/TGX A807
S13S A887
S14 A888
S14SC A888
S14SCX A888
S15 A888
S16 A888
S16SC A888
S16SCX A888
S17 A888
S17SC A888
S17SCX A888
S18 A888
S18SC A888
S18SCX A888
S19SCX A888
S20SCX A889
S21 A889
S22 A889
S23 A889
S31 A893
S40 A889
S41 A889
S103/1066 A112
S104/1056 A112
S107/1086 A112
S204S9E2 A110
S204SD9E2 A110
S2046 A110
S5001 A890
S5002 A890
S5009 A890
S5011 A890
S5012 A890
S5054 A890
S5055 A890
S5056 A890
S5057 A890
S5069 A891
S5080 A891
S5081 A891
S5082 A891
S5083 A891
S5095 A891
SAS5/6C8E2 A104
SAS5/6R9E2 A104
SAS5/6XE2 A104
SAS5/69E2 A104
SAS7/8C8E2 A104

SAS7/8R9E2 A104
SAS7/8RXE2 A104
SAS7/8XE2 A104
SAS7/89E2 A104
SAS11/12C8E2 A105
SAS11/12R9E2 A105
SAS11/12XE2 A105
SAS11/129E2 A105
SAS13/14C8E2 A105
SAS13/14R9E2 A105
SAS13/14RXE2 A105
SAS13/14XE2 A105
SAS13/149E2 A105
SC2R/2L9E2 A107
SC2R/2LC8E2 A107
SC4R/4L9E2 A107
SC4R/4LC8E2 A107
SC13/149E2 A107
SC13R/14LC8E2 A107
SCGC A892
SCGCP A892
SCGS A892
SCNEVI19E2 A109
SCNEVI29E2 A109
SCNEVI39E2 A109
SCNEVI49E2 A109
SCORT A892
SCORTSC A892
SDCM/D7 A113
SDCN7 A113
SDKCLIP A202
SDKGPLATE A202
SDKGPSCREW A202
SDKKIT A202
SDKSTCOARS A202
SDKSTONEA A202
SDKSTONEC A202
SDM16 A108
SDM26 A108
SDP5/6K A113
SDP9/11K A113
SG1/29APE2 A106
SG5/6C8E2 A103
SG5/6R9E2 A103
SG5/6XE2 A103
SG5/69E2 A103
SG7/8C8E2 A103
SG7/8R9E2 A103
SG7/8XE2 A103
SG7/89APE2 A106
SG7/89E2 A103
SG11/12C8E2 A103
SG11/12R9E2 A103
SG11/12XE2 A103
SG11/129APE2 A106
SG11/129E2 A103
SG13/14C8E2 A103

SG13/14R9E2 A103
SG13/14XE2 A103
SG13/149APE2 A106
SG13/149E2 A103
SGC1/26 A106
SGC11/126 A106
SGC13/146 A106
SGCSUB-06 A106
SGRT A873
SGRTB A873
SH5/339E2 A110
SH6/79E2 A110
SHDPV A885
SHTMBH A885
SINC1 A845
SINC1S6 A845
SINC1SX A845
SINC1X A845
SINC2 A845
SINC2S6 A845
SINC2SX A845
SINC2X A845
SJC A892
SJS A892
SK8/9 A813
SK8/96 A813
SKN3/46 A813
SKN46 A813
SKRA16 A813
SKRA26 A813
SKRA36 A813
SKRA39 A813
SL1/29E2 A107
SL3/49E2 A107
SL5/69E2 A107
SLB A892
SM13/14S9E2 A111
SM13/149E2 A111
SM17/189E2 A111
SMB A892
SMS1/29E2 A105
SMS7/89E2 A105
SMS11/129E2 A105
SMS13/149E2 A105
SNEV1/H59E2 A109
SOUNDG A619
SOUNDGS A619
SP20 A897
SP20SLEM A897
SP6061 A610
SP60616 A610
SPAL13K6 A807
SPAL13KS6 A807
SPAL13KX A807
SPM20 A898
SPNHDPVN A859
SPP24GSICX A869

SPP24GSP2X A869
SPP24GSPX A869
SPPH2X A869
SPPSCHLEEX A869
SPR1/2 A814
SPR1/2S A814
SPR1/2S6 A814
SPR1/26 A814
SPR1/29 A814
SPSPV A893
SPSPV45 A893
SPTPDAPV A898
SPTPDSSPV A898
SPV A893
SPVX A893
SQBL16 A108
SQBL26 A108
SQLL36 A108
SQMD16 A108
SQMD26 A108
SR1 A875
SR2 A875
SR3 A875
SR8 A873
SR9 A873
SR50 A873
SRC3M A874
SRM10 A874
SRM15 A874
SRMALO A875
SRPG5/6C8E2 A104
SRPG5/69E2 A104
SRPG7/8C8E2 A104
SRPG7/89E2 A104
SRPG11/12C8E2 A104
SRPG11/129E2 A104
SRPG13/14C8E2 A104
SRPG13/149E2 A104
SS2 A204
SS4 A204
SS5 A204
SS5/6 A814
SS5/66 A814
SS9/10 A814
SS9/106 A814
SS11/12 A814
SS11/126 A814
SS299 A204
SSDGRIT A205
SSF1 A205
SSKC A205
SSKITA A204
SSO A204
SSPR1 A845
STKSKLS A894
STMBH A893
SYBG A894

SYG7/8C8E2 A107
SYG7/89E2 A107
SYRA A894
SYRCW A894

T

TABANELLA1 A842
TABANELLA2 A842
TABANELLA3 A809
TABANELLA4 A809
TF45 A902
TFB A902
TFS A902
TK018 A714
TKN1 A852
TKN1CH A852
TKN1S6 A852
TKN1SX A852
TKN1X A852
TKN2 A852
TKN2CH A852
TKN2S6 A852
TKN2SX A852
TKN2X A852
TKSTEIG A852
TKSTEIG2 A852
TNBB18 A605
TNBB21B A605
TNBB27/29 A605
TNBBS/M A606
TNCCIB A606
TNCCID A606
TNCCIE A606
TNCCIF A606
TNCCIG A606
TNCIGFT1 A604
TNCIGFT2 A604
TNCIGFT3 A604
TNCIGFT4 A604
TNCIGFT5 A605
TNCIGFT6 A605
TNCIGFTMI1 A605
TNCIGFTMI3 A605
TNCIGFTMI4 A605
TNCIPCS A605
TNCVIPC A605
TNPFIA8 A605
TNPFIA6 A605
TNPFIA2 A605
TP16 A895
TP31 A895
TP32 A895
TP33 A895
TP34 A895
TP41 A896

TP42 A896
TP43 A896
TP43A A896
TP50 A896
TP50L A896
TP5041 A900
TP5042 A900
TP5043 A900
TP5050 A900
TP5051 A900
TP5060 A900
TP5061 A900
TP5062 A901
TP5070 A901
TP5071 A901
TP5072 A901
TP5080 A901
TP5090 A901
TP5091 A901
TPA A895
TPA15 A896
TPASTMBH A898
TPDAPV A898
TPDSCPV A898
TPDSSPV A899
TPG1 A896
TPG3 A896
TPG4 A897
TPKN A897
TPMSA A897
TPR6 A897
TPR8 A897
TPSLASCHLE A899
TPSLCOCMN A899
TPSLCOSM A899
TPSLSSCHLE A899
TPSSTMBH A899
TRA2 A875
TRFB A872
TRH1 A874
TRH2 A874
TRH2/3 A874
TRH3 A874

V

VENSTAB A618
VENSTABS A618

X

XP23/QOW6 A307
XP23/UNC6 A307

The Best In Practice



本图册以及本图册收录的内容,包括但不限于所有文字、数据、图片、图表、版面设计、排版方式、标识的所有权、著作权等知识产权以及其他权利均为 Hu-Friedy Mfg. Co., LLC 及其附属公司或关联公司专属所有。未经事先书面许可,不得擅自使用,包括但不限于以任何形式使用、复制、转让、发行、传播、转载、出版、修改、改编或曲解本图册收录的内容。

除非另有说明,否则所有标识均在 Hu-Friedy Mfg. Co., LLC 及其附属公司或关联公司的商标权的范围内,包括公司名称、产品名称、文字/图形及其组合、品牌名称、标识等。未经事先书面许可,不得使用本图册中任何商标的全部或部分。

豪孚迪医疗器械(上海)有限公司

地址:上海市浦东新区康桥东路1365弄29号 客服电话:021-68183182*843

邮箱:customer_service_china@hu-friedy.com | 中文网站: <https://www.hufriedygroup.com/china/zh-hans>

HF-120ZH/0923